

11SV013 PLAT OF LOT 89 AND LOT 4A OF BLOCK 1 OF CANYON SPRINGS PRESERVE, FORMERLY A PORTION OF COMMON AREA 1 OF BLOCK 1 OF CANYON SPRINGS PRESERVE, AND FORMERLY LOT 4 OF BLOCK 1 OF CANYON SPRINGS PRESERVE, LOCATED IN THE NE1/4SW1/4 OF SECTION 23, T.2N,R.6E, OF THE BLACK HILLS MERIDIAN, PENNINGTON COUNTY, SOUTH DAKOTA
SHEET 1 OF 2

(THAT PORTION OF COMMON AREA 1 DESCRIBED IN DEED, BOOK 199 PAGE 3106)
(COMMON AREA 1 PLAT BOOK 33 PAGE 190)

LEGEND

- FOUND PLASTIC CAP KLJ 5436
- SET CORNER LS 5086

LINE	BEARING	DISTANCE
L1	S 78°40'59" W	108.44'
L2	N 30°21'13" W	154.27'
L3	N 57°34'50" W	195.17'
L4	N 35°05'04" E	242.70'
L5	S 29°45'32" E	156.46'
L6	S 24°14'06" W	172.17'

RECEIVED

AUG 12 2011

Rapid City Growth Management Department

SURVEY NOTES:

8' UTILITY AND MINOR DRAINAGE EASEMENTS ARE HEREBY GRANTED ON THE INTERIOR OF ALL LOT LINES, EXCEPT AS NOTED.

GENERAL NOTES:

1. AT THE TIME A BUILDING PERMIT APPLICATION IS SUBMITTED, A RESERVE DRAINFIELD AREA FOR ON-SITE WASTEWATER TREATMENT WILL BE IDENTIFIED AND HELD IN RESERVE UNLESS A PUBLIC SEWER SYSTEM IS PROVIDED.

2. PRIOR TO OBTAINING A BUILDING PERMIT FOR A RESIDENCE ON ANY OF THE LOTS, TWO SUITABLE ON-SITE WASTEWATER SYSTEM AREAS SHALL BE IDENTIFIED WITH ACCOMPANYING PERCOLATION TESTS AND SOIL PROFILES CERTIFIED BY A REGISTERED PROFESSIONAL ENGINEER. ANY SEPTIC SYSTEM TO BE LOCATED ON ANY OF THE PROPERTIES SHALL BE DESIGNED AND CERTIFIED BY A REGISTERED PROFESSIONAL ENGINEER BASED ON SPECIFIC SOIL AND GEOLOGIC CONDITIONS. SOIL PROFILES SHALL SHOW THAT PROPER SOIL SEPARATION CAN BE OBTAINED AS OUTLINED IN STATE ADMINISTRATIVE RULE 74:53:01:32. IF THE PERCOLATION AND SOIL PROFILE INFORMATION DO NOT MEET THESE REQUIREMENTS AN ALTERNATIVE SYSTEM APPROVED BY THE SOUTH DAKOTA DEPARTMENT OF ENVIRONMENT AND NATURAL RESOURCES MAY BE USED. AS A LAST RESORT, PENNINGTON COUNTY MAY APPROVE THE USE OF HOLDING TANKS.

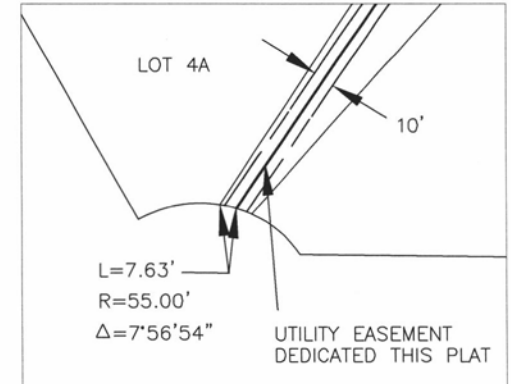
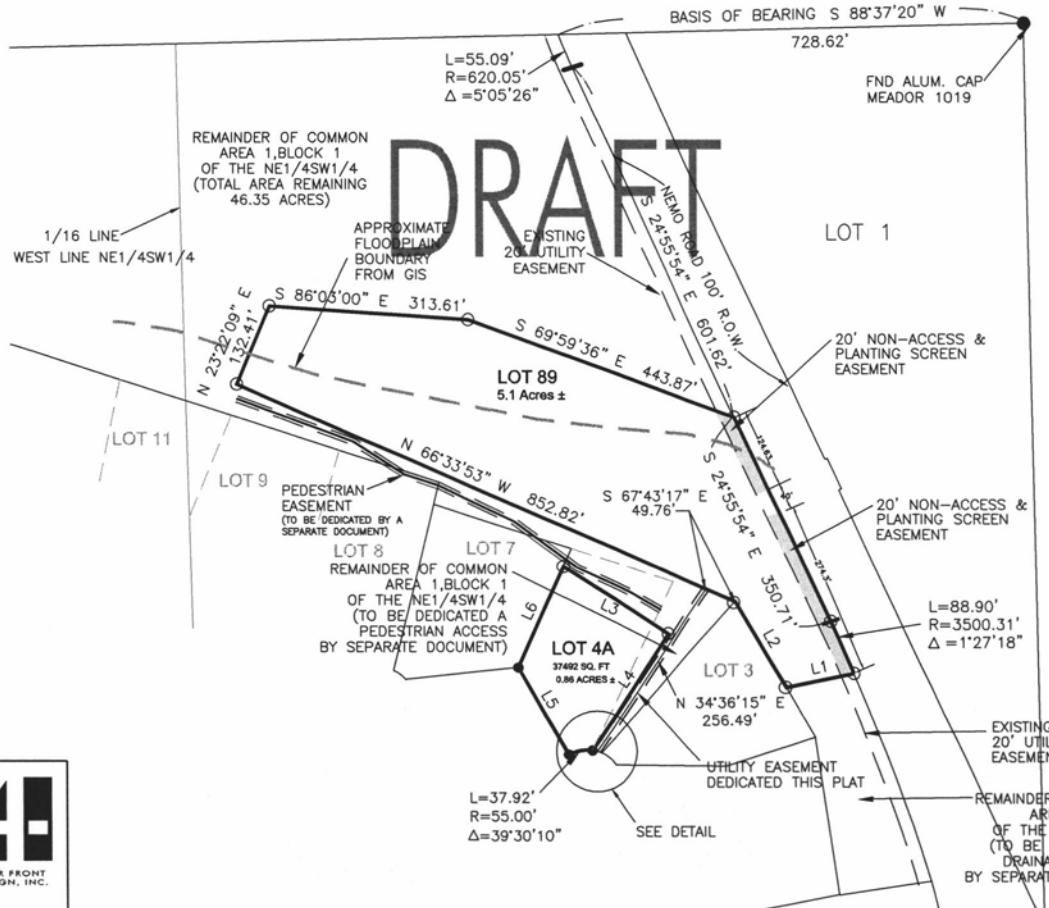

DETAIL NOTES

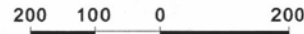

HORIZ. SCALE: 1"=200'

Plot prepared by:

FOUR FRONT DESIGN, INC.
517 7th street
rapid city sd 57701
ph: 605.342.9470
fax: 605.342.2377
www.4front.biz



FOUR FRONT DESIGN, INC.

ARCHITECTURE | ENGINEERING
GIS SURVEYING

PLAT OF LOT 89 AND LOT 4A OF BLOCK 1 OF CANYON SPRINGS PRESERVE, FORMERLY A PORTION OF COMMON AREA 1 OF BLOCK 1 OF CANYON SPRINGS PRESERVE, AND FORMERLY LOT 4 OF BLOCK 1 OF CANYON SPRINGS PRESERVE, LOCATED IN THE NE1/4SW1/4 OF SECTION 23, T.2N,R.6E, OF THE BLACK HILLS MERIDIAN, PENNINGTON COUNTY, SOUTH DAKOTA SHEET 2 OF 2

(THAT PORTION OF COMMON AREA 1 DESCRIBED IN DEED, BOOK 199 PAGE 3106) (COMMON AREA 1 PLAT BOOK 33 PAGE 190)

RECEIVED

AUG 12 2011

CERTIFICATE OF OWNERSHIP STATE OF SOUTH DAKOTA COUNTY OF PENNINGTON S.S.

I/WE... DO HEREBY CERTIFY THAT I/WE ARE THE OWNER OF THE TRACT OF LAND SHOWN AND DESCRIBED HEREON, THAT THE PLAT WAS DONE AT OUR REQUEST FOR THE PURPOSES INDICATED HEREON, AND THAT WE DO HEREBY APPROVE THE WITHIN PLAT OF SAID LAND, AND THAT THE DEVELOPMENT OF THIS LAND SHALL CONFORM TO ALL EXISTING APPLICABLE ZONING, SUBDIVISION, EROSION, AND SEDIMENT CONTROL REGULATIONS.

ANY LAND SHOWN ON THE WITHIN PLAT AS DEDICATED TO PUBLIC RIGHT-OF-WAY IS HEREBY DEDICATED TO PUBLIC USE AND PUBLIC UTILITY USE AS SUCH FOREVER, BUT SUCH DEDICATION SHALL NOT BE CONSTRUED TO BE A DONATION OF THE FEE OF SUCH LAND.

IN WITNESS WHEREOF, I HAVE SET MY HAND AND SEAL.

OWNERS: ADDRESS: ADDRESS:

ON THIS... DAY OF... 20... BEFORE ME, A NOTARY PUBLIC, PERSONALLY APPEARED... MANAGING MEMBER, KNOWN TO ME TO BE THE PERSON DESCRIBED IN THE FOREGOING INSTRUMENT AND ACKNOWLEDGED TO ME THAT SHE SIGNED THE SAME.

NOTARY PUBLIC: MY COMMISSION EXPIRES:

IN WITNESS WHEREOF, I HAVE SET MY HAND AND SEAL.

CERTIFICATE OF FINANCE OFFICER

I, FINANCE OFFICER OF THE CITY OF RAPID CITY, DO HEREBY CERTIFY THAT THE GROWTH MANAGEMENT DIRECTOR OF THE CITY OF RAPID CITY, HAS APPROVED THIS FINAL PLAT AS SHOWN.

DATED THIS... DAY OF... 20...

FINANCE OFFICER OF THE CITY OF RAPID CITY

CERTIFICATE OF SURVEYOR

I, RANDY L. DEIBERT, REGISTERED LAND SURVEYOR NO. 5086 OF THE STATE OF SOUTH DAKOTA, DO HEREBY CERTIFY THAT AT THE REQUEST OF THE OWNERS LISTED HEREON, I HAVE SURVEYED THE TRACT OF LAND SHOWN, AND TO THE BEST OF MY KNOWLEDGE AND BELIEF, THE WITHIN PLAT IS A REPRESENTATION OF SAID SURVEY.

IN WITNESS WHEREOF, I HAVE HEREUNTO SET MY HAND AND SEAL.

DRAFT

RANDY L. DEIBERT, REGISTERED LAND SURVEYOR DATE

CERTIFICATION OF GROWTH MANAGEMENT DIRECTOR STATE OF SOUTH DAKOTA COUNTY OF PENNINGTON S.S.

I, GROWTH MANAGEMENT DIRECTOR OF CITY OF RAPID CITY, HAVE REVIEWED THIS PLAT AND HAVE FOUND IT TO CONFORM TO THE SUBDIVISION REQUIREMENTS OF CHAPTER 16.08.035 OF THE RAPID CITY MUNICIPAL CODE AND AS SUCH I HAVE APPROVED THIS PLAT AS FINAL PLAT.

DAY OF... 20...

GROWTH MANAGEMENT DIRECTOR OF THE CITY OF RAPID CITY

CERTIFICATE OF FINANCE OFFICER

I, FINANCE OFFICER OF THE CITY OF RAPID CITY, DO HEREBY CERTIFY THAT ALL SPECIAL ASSESSMENTS WHICH ARE LIENS UPON THE WITHIN-DESCRIBED LANDS ARE FULLY PAID ACCORDING TO THE RECORDS OF MY OFFICE.

DATED THIS... DAY OF... 20...

FINANCE OFFICER OF THE CITY OF RAPID CITY

CERTIFICATE OF HIGHWAY OR STREET AUTHORITY

THE LOCATION OF... THE HIGHWAY OR STREET AS SHOWN HEREON IS HEREBY APPROVED. ANY APPROACHES OR ACCESS TO THE HIGHWAY OR STREET WILL REQUIRE ADDITIONAL APPROVAL. DATED THIS... DAY OF... 20...

HIGHWAY OR STREET AUTHORITY

CERTIFICATE OF COUNTY TREASURER

I, TREASURER OF PENNINGTON COUNTY, DO HEREBY CERTIFY THAT ALL TAXES WHICH ARE LIENS UPON THE WITHIN-DESCRIBED LANDS ARE FULLY PAID ACCORDING TO THE RECORDS OF MY OFFICE.

DATED THIS... DAY OF... 20...

TREASURER OF PENNINGTON COUNTY

CERTIFICATE OF REGISTER OF DEEDS STATE OF SOUTH DAKOTA COUNTY OF PENNINGTON S.S.

FILED... DAY OF... 20...

IN BOOK... OF PLATS, ON PAGE...

REGISTER OF DEEDS

CERTIFICATE OF DIRECTOR OF EQUALIZATION

I, DIRECTOR OF EQUALIZATION OF PENNINGTON COUNTY, DO HEREBY CERTIFY THAT I HAVE ON RECORD IN MY OFFICE A COPY OF THE WITHIN-DESCRIBED PLAT.

DATED THIS... DAY OF... 20...

DIRECTOR OF EQUALIZATION OF PENNINGTON COUNTY

APPROVED: DIRECTOR OF EQUALIZATION OF PENNINGTON COUNTY

Plot prepared by: FOUR FRONT DESIGN, INC. 517 7th street rapid city sd 57701 ph: 605.342.9470 fax: 605.342.2377 www.4front.biz ARCHITECTURE | ENGINEERING | SURVEYING