

ACOUSTICAL ASSESSMENT REPORT

Evaluation of Potential Noise Level Impact from WalMart (proposed) Rapid City, Pennington County, South Dakota

**Assessment of Noise Level Elements Associated with Operation of a WalMart
Located at E. Stumer Road and Black Hills Boulevard including Twenty-four Hour
Baseline Sound Level Measurements**

June 2, 2010

10006-01

INTRODUCTION

This study was conducted at the request of Larry Webb, Associate AIA of Law/Kingdon, Inc., Architects•Engineers•Planners to assess the potential for environmental noise impact due to sound levels generated by the operation of a WalMart proposed for construction at the intersection of E. Stumer Road and Black Hills Boulevard near both single family and multi-family housing in Rapid City, South Dakota. The intent is provide acoustical planning information to facilitate Rapid City's desire for community compatibility.

The sound levels associated with various items of equipment identified as being operated by or caused to be operated by a WalMart facility have been considered. Those items of equipment include Roof-Top Air-conditioning Units (RTU), Refrigeration Compressor Air-cooled Condensers, Roof-Mounted Exhaust Fans (REF), Pharmacy Loudspeakers, Trash Compactor, Snow Throwers, Back-up Alarms, and Commercial Tractor/Trailer Trucks. The sound levels associated with this items have been projected to various distances to aid in identifying the extend to which this sound levels may or may not be noticed in the residential areas.

The WalMart site is bounded by E. Stumer Road on the south and office commercial zoned, undeveloped sites on the north, east and west. The northwest corner of the site is the nearest point to the single-family residences located on Savoy Circle.

Randorff and Associates Incorporated

June 2, 2010

Acoustical Assessment Report
Evaluation of Potential Noise Level Impact from
WalMart (proposed)
Rapid City, Pennington County, South Dakota

Page 2

The Rapid City Growth Management Department has determined that the operation of the WalMart should not be allowed to exceed a day-night equivalent continuous sound level of 65 dBA at the commercial property line. To support the environmental noise level assessment, the existing day-night equivalent continuous sound level has been measured at four property line positions nearest to the residential areas in concern.

The sound level measurements and the preparation of this report were performed in accordance with the following requirements of the American National Standards Institute(ANSI).

ANSI S1.2-62	Method for the Physical Measurement of Sound (R 1976)
ANSI S1.4-1983/85A	Specification for Sound Level Meters (R 2001)
ANSI S1.6-1984	Preferred Frequencies, Frequency Levels, and Band Numbers for Acoustical Measurements (R 2001)
ANSI S1.11-1986	Specifications for Octave-Band and Fractional-Octave Band Analog and Digital Filters (R 1998)
ANSI S1.13-1995	Method for Measurement of Sound Pressure Levels (R 1999)
ANSI S1.40-1984	Specification for Acoustical Calibrators(R 2001)
ANSI S12.9-1988	Quantities and Procedures for Description and Measurement of Environmental Sound. Part I (R 1998)
ANSI S12.40-1990	Sound Level Descriptors for Determination of Compatible Land Use (R 1996)

SOUND DESCRIPTORS

Sound pressure levels are measured in decibels(dB). The decibel is a dimensionless unit based on a logarithmic system which can express a wide range of sound pressure levels in a compressed scale. Environmental sound level measurements are usually made using the A-weighted decibel(dBA) which simulates the overall frequency response

Randorff and Associates Incorporated

June 2, 2010

Acoustical Assessment Report
Evaluation of Potential Noise Level Impact from
WalMart (proposed)
Rapid City, Pennington County, South Dakota

Page 3

of the human ear. Several types of measurement parameters are available to quantify environmental sound levels using A-weighted decibels. For example, the Federal Highway Administration(FHWA) states its noise standards in terms of A-weighted equivalent continuous sound level, L_{eq} . The L_{eq} is defined as the level of a steady state sound which, if produced over a stated time period at a specified location, has the same A-weighted sound energy as the time-varying sound being measured. The L_{eq} can be measured over any designated time period, although it is generally considered on an hourly basis. It is sometimes referred to as the average sound level. The noise regulations of the U.S. Department of Housing and Urban Development(HUD), the Federal Aviation Regulations(FAR) Part 150 and the Federal Energy Regulatory Commission(FERC) are given in terms of the day-night average sound level, commonly referred to as either L_{dn} or DNL. This is a 24-hour measurement of the equivalent continuous sound level with a 10 dBA penalty added to the sound levels occurring at night to account for increased sensitivity to noise received during that time period. Nighttime is considered to be the period between 10:00 pm and 7:00 am. Daytime is defined as the period between 7:00 am and 10:00 pm.

In judging whether or not a change in ambient sound levels is significant, the following guidelines are accepted for general use. Under laboratory conditions, a 10 dBA increase in sound levels has been judged as a doubling of the sound perceived by the human ear. A 3 dBA increase has been judged as barely perceptible. As established by Federal guidelines, a 5 dBA increase is a noticeable change; a 10 dBA increase is considered a significant change; and a 15 dBA increase is a serious change. Sound levels which have distinct tonal characteristics or are impulsive are understood to be more intrusive than continuous, random frequency sound levels. Tonal and impulsive types of sound are easily recognized even when their actual level is only equal to the general

Randorff and Associates Incorporated

June 2, 2010

Acoustical Assessment Report
Evaluation of Potential Noise Level Impact from
WalMart (proposed)
Rapid City, Pennington County, South Dakota

Page 4

background or ambient sound levels. For discrete tones to be judged as undetected, they must be at least 10 dB below the background sound levels. In recognition of this fact, many municipal noise regulation ordinances require that tonal sounds be limited at levels either 5 or 10 dB below the limits set for continuous or quasi-continuous sounds, especially with respect to residential receptors.

SOUND LEVEL MEASUREMENTS

Sound level measurements were conducted for a 24-hour period beginning at approximately 10:00 am Wednesday, April 28, 2010 and concluding late Thursday morning, April 29, 2010. With the assistance of Eric Howard, RLS, of Renner & Associates LLC four positions were chosen; one located at the northwest corner of the WalMart site; one located along the west property line, 190 feet south from the northwest corner; one located along the west property line, 280 feet south from the northwest corner; along the west property line, 480 feet south from the northwest corner tending toward E. Stumer Road. T.J. Aisenbrey, also with Renner & Associates LLC was present during the set-up of the sound level monitors. The principal observed sources of sound were vehicular traffic on State Highway 16 Truck Route and on Fifth Street. No nature sounds such as insects or birds were especially noticeable. The measurement positions, sound level measurement equipment, and weather conditions are described as follows:

Measurement Positions

Position 1: Located at the northwest corner of the commercially zoned site for the proposed WalMart. This location is adjacent to a office commercial zoned lot north of the WalMart site. The microphone of the sound level monitor was positioned 4-feet 2-inches above the

Randorff and Associates Incorporated

June 2, 2010

Acoustical Assessment Report
Evaluation of Potential Noise Level Impact from
WalMart (proposed)
Rapid City, Pennington County, South Dakota

Page 5

ground. This position is approximately 200 feet from the nearest single-family residence on Savoy Circle and approximately 925 feet from the nearest multi-family residences.

Position 2: Located on the west property line approximately 190 feet south of the northwest corner. This location is adjacent to the office commercial zoned lot west of the WalMart site. The microphone of the sound level monitor was positioned 4-feet 4-inches above the ground.

Position 3: Located on the west property line approximately 280 feet south of the northwest corner. This location is adjacent to the office commercial zoned lot west of the WalMart site. The microphone of the sound level monitor was positioned 4-feet 4-inches above the ground.

Position 4: Located on the west property line approximately 480 feet south of the northwest corner. This location is adjacent to the office commercial zoned lot west of the WalMart site. The microphone of the sound level monitor was positioned 4-feet 4-inches above the ground. This position is approximately 550 feet from the nearest single-family residence on Savoy Circle and approximately 650 feet from the nearest multi-family residences.

These four measurement positions are also noted on the attached site plan.

Measurement Equipment

Metrosonics cl-304 Calibrator, SN 2127

Metrosonics db-301A Metrologgers, SN 3864, 3865, 3866, 1838

GenRad 1982 Type 1 Precision Sound Level Meter, SN 1166

GenRad 1562A Calibrator, SN 23917

Randorff and Associates Incorporated

June 2, 2010

Acoustical Assessment Report
Evaluation of Potential Noise Level Impact from
WalMart (proposed)
Rapid City, Pennington County, South Dakota

Page 6

Weather Conditions

April 28, 2010 (10:55 am)

Sky:	Partly cloudy
Temperature:	74 °F
Relative Humidity:	30 %
Wind:	2-8 mph, Southwest

April 28, 2010 (5:15 pm)

Sky:	Cloudy
Temperature:	67 °F
Relative Humidity:	26 %
Wind:	10 mph, West

April 29, 2010 (10:30 am)

Sky:	Partly cloudy
Temperature:	65 °F
Relative Humidity:	34 %
Wind:	5 mph, Northeast

MEASUREMENT RESULTS

The results of the sound measurements taken at the four positions were as follows:

- Position 1: L_{dn} , or DNL, of 54 dBA
- Position 2: L_{dn} , or DNL, of 57 dBA
- Position 3: L_{dn} , or DNL, of 58 dBA
- Position 4: L_{dn} , or DNL, of 58 dBA

Graphs of twenty-four hour sound data acquired at the four measurements positions are included as an attachment to this report. These data tend to support the observation that vehicular traffic, especially along SH 16 Truck Route, is the principal source of sound for the present. Position 1 also experienced some shielding due to the lower elevation of the drainage ditch which runs nominally west to east toward a retention pond near Fifth Street.

Randorff and Associates

Incorporated

June 2, 2010

Acoustical Assessment Report
Evaluation of Potential Noise Level Impact from
WalMart (proposed)
Rapid City, Pennington County, South Dakota

Page 7

SOUND SOURCES AND SOUND LEVELS

While the actual mechanical design and architectural layout, with respect to the items of equipment previously noted, will influence the sound levels at the commercial property line of the WalMart, the sound levels associated with the various pieces of equipment are given for various distances removed from the equipment. This should allow a ready comparison of sound levels that might be received by residents at different locations relative to the WalMart. The geometric center of the WalMart is approximately 625 feet from the nearest single-family residence on Savoy Circle and 1000 feet from the nearest multi-family residences.

- The RTUs manufactured by Munters are to be specified with two cooling fans. The two different units being considered for the WalMart, with both cooling fans operating, have sound levels of 70 dBA and 77 dBA respectively when measured at 15 feet. The simplest calculation for spherical spreading yields 52 dBA and 59 dBA at 120 feet and 46 dBA and 53 dBA at 240 feet.
- The largest Air-cooled Condenser manufactured by Bohn being considered for the WalMart has eight cooling fans. The sound level measured at 10 feet is 72 dBA with all fans operating. This calculates to 48 dBA at 160 feet and 42 dBA at 320 feet.
- The largest REF manufactured by ACME being considered for the WalMart produces an estimated sound level of 66 dBA at 10 feet. This estimate is based on the sones reported by ACME and should be re-verified in terms of actual A-weighted decibels by ACME or another manufacturer who can supply certified data. The estimated sound level at 160 feet is 42 dBA and at 320 feet is 36 dBA.
- The drive-through pharmacy loudspeakers produce an average of 80 dBA measured at 3 feet. This data was obtained at an operating WalMart Supercenter in Lubbock, Texas on May 7, 2010 under the assumption that similar audio equipment will be

Randorff and Associates

Incorporated

June 2, 2010

Acoustical Assessment Report
Evaluation of Potential Noise Level Impact from
WalMart (proposed)
Rapid City, Pennington County, South Dakota

Page 8

furnished by WalMart for the Rapid City WalMart presently under consideration. This permits calculated average sound levels of 56 dBA at 48 feet and 50 dBA at 96 feet.

- The Trash Compactor manufactured by Cram-A-Lot being considered for the WalMart produces 69 dBA measured at 3 feet and 60 dBA at 15 feet. Calculation yields 42 dBA at 160 feet and 36 dBA at 320 feet.
- Snow Throwers, as opposed to snow blowers, are available from many manufacturers. A review of available manufacturers showed a highest level of sound to be 72 dBA produced at 22 feet. This yields calculated sound levels of 54 dBA at 176 feet and 48 dBA at 352 feet.
- Back-up Alarms are available in several varieties. A sample review of the products by ECCO covers original equipment manufacturer (OEM) alarms and after-market alarms. The sound levels of these devices can either be pre-set at a fixed sound level or be set as a variable sound level relative to the ambient sound. The loudest of these fixed alarms produce from 87 dBA to 112 dBA measured at 3 feet. The least of these levels would produce a calculated 51 dBA at 192 feet while the loudest delivers 76 dBA at 192 feet. The choice of back-up alarms should be reviewed carefully with the final choice possibly being a variable volume alarm such as ECCO's model SA950 which generates a back-up warning 5 dBA louder than the ambient background sound level; beginning at 82 dBA and capable of reaching a maximum level of 102 dBA. Equipment requiring back-up alarms should be acquired with careful attention to the OEM Back-up Alarms.
- Commercial Tractor/Trailer Trucks have maximum sound levels which are regulated by the Federal Government Department of Transportation. The enabling legislation was Title 49, Code of Federal Regulations (CFR), Chapter II, Part 325 promulgated in 1975. The code was amended in 1989 to require somewhat lower noise levels

Randorff and Associates Incorporated

June 2, 2010

Acoustical Assessment Report
Evaluation of Potential Noise Level Impact from
WalMart (proposed)
Rapid City, Pennington County, South Dakota

Page 9

than was originally legislated. As such, all operating tractor/trailer trucks cannot exceed 83 dBA when traveling less than 35 mph at a distance of 70 feet when measured over a hard surface such as a parking lot. When measured over a grassy area or field, a tractor/trailer truck cannot exceed 81 dBA at 70 feet. By using an average of 82 dBA where a combination of pavement and grass will be present allows a calculated sound level of 75 dBA at 140 feet and 69 dBA at 280. The contribution to the property line L_{dn} , or DNL, will depend upon the amount of time the truck(s) are actually operated prior to parking and unloading.

UNIQUE WEATHER CONDITIONS OR ANOMALIES

There is no reason to believe that sound levels transmitted between the Walmart and the nearest residences will be altered by anomalous weather conditions. This is due to the residences being less than a quarter of a mile from the Walmart.

However, for the purposes of thoroughness it should be noted that atmospheric conditions can have substantial effect on the propagation of sound over long distances. Typically, sound levels decrease inversely with increasing distance from the source. In the free field, sound from a point source decreases by 6 dB for each doubling of distance. However, at distances greater than a thousand feet, atmospheric effects can begin to significantly change this sound reduction axiom. Factors such as relative humidity, temperature gradients and wind can affect sound propagation.

At a given temperature, higher humidity generally decreases the molecular absorption characteristics of air. This allows sound to propagate farther. Perhaps this is why fog horns seem to be louder in a heavy fog than simply a cloudy night. The amount of

Randorff and Associates Incorporated

June 2, 2010

Acoustical Assessment Report
Evaluation of Potential Noise Level Impact from
WalMart (proposed)
Rapid City, Pennington County, South Dakota

Page 10

sound absorption produced by air is also dependent on the sound frequency. Air selectively attenuates higher frequencies much more than low frequencies.

Vertical temperature gradients exist over open ground. The corresponding variation in density with elevation causes the speed of sound to be different at different heights. In turn, this causes sound waves to bend upward and downward. On sunny calm days, air temperature usually decreases with altitude. Meteorologists refer to this as a lapse condition. When this condition is present, sound waves gradually bend upward, away from sound receptors on the ground. Sound levels thus drop more quickly with increasing distance. Over long distances, the sound will attenuate more than the 6 dB rule for doubling of distance. On calm, clear nights, temperature inversions can occur, with the lowest temperatures being near the ground. Sound waves are refracted downward under these conditions, resulting in greater sound propagation over longer distances. An inversion can cause sound waves to bend over obstructions and be repeatedly reflected off the ground. Double temperature gradients are also possible with an inversion layer existing above a lapse condition. The discrete change in air density between the layers can also reflect sound back down toward the ground. Therefore, sound can be channeled over longer distances under conditions of a temperature inversion.

Wind direction and wind gradient may have the greatest affect on sound propagation. Wind speed is usually lower near the ground due to frictional drag. The resulting gradient in wind speed causes sound waves to refract up when traveling into the wind and down when traveling with the wind. Upwind of a sound source, sound levels are typically reduced because the sound waves are bent up and away from the receptors. Downwind, sound propagation can be enhanced by bending over obstructions and by

Randorff and Associates Incorporated

June 2, 2010

Acoustical Assessment Report
Evaluation of Potential Noise Level Impact from
WalMart (proposed)
Rapid City, Pennington County, South Dakota

Page 11

reflections off the ground. In short, sound tends to propagate farther downwind than upwind.

As a point of interest, for very unique weather conditions, the nearby residents, as well as the other more distant residents, could receive anomalous levels of sound from other sources and mistakenly associate those sounds with WalMart. Under conditions of temperature inversions, it would be possible for residents to hear sounds which were produced several miles away. Traffic sound levels from not only main State Highway 16 to the west but even from Interstate 90 may be heard more distinctly than nearby traffic on SH 16 Truck Route. Sound levels from the mechanical equipment of businesses on SH 16, the Mount Rushmore Highway, might seem to intensify briefly under these conditions. Such cases of acoustical intrusion might be expected to occur in the late night or very early morning hours during the winter months.

SUMMARY AND CONCLUSION

The maximum allowable property line sound level of L_{dn} 65 dBA was established by Rapid City Growth Management Department. The results of this study indicate that the sound levels at the WalMart property lines will be below the allowable maximum. According to the site plan, the nearest residences to the proposed development are buffered by office commercial lots. The sound level experienced at the residential lots will be less than that received on the two adjacent office commercial lots and also below the established maximum level. Furthermore, while there are no intervening buildings or other structures between the WalMart site and the residences, as further development occurs it is likely that some sound level shielding will be provided by other buildings. Exactly how much shielding may be provided is not known at this time and has not been considered in this study.

Randorff and Associates Incorporated

June 2, 2010

Acoustical Assessment Report
Evaluation of Potential Noise Level Impact from
WalMart (proposed)
Rapid City, Pennington County, South Dakota

Page 12

It is concluded that the sound limit requirements set forth by Rapid City Growth Management Department are reasonable. It is further concluded that the environmental systems mechanical equipment; the operations equipment; and the maintenance equipment identified and considered in the assessment should produce no more than the Rapid City allowable sound levels at the WalMart property line. This conclusion is based on review of the preliminary concept plans and the assumption that adequate care and attention are given during the architectural and engineering design process with respect to the combining, locating and, if necessary, abating the sound sources identified in the assessment.

This concludes the environmental sound level assessment thus far. Should further site measurements, community noise research, or acoustical consultation be deemed necessary please do not hesitate to ask. If there are any comments or questions please call me.

Submitted by:

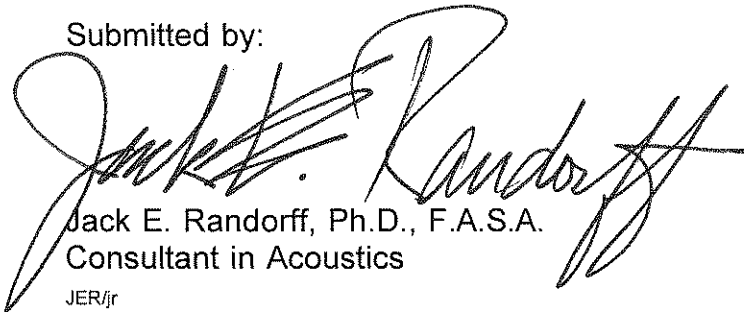

Jack E. Randorff, Ph.D., F.A.S.A.
Consultant in Acoustics

JER/jr
C:\RAI\10006-B.REP

attach: Site Plan with Sound Measurement Positions noted

- Figure 1. WalMart-24hr Sound Measurements, Position 1, 4-28-10
- Figure 2. WalMart-24hr Sound Measurements, Position 2, 4-28-10
- Figure 3. WalMart-24hr Sound Measurements, Position 3, 4-28-10
- Figure 4. WalMart-24hr Sound Measurements, Position 4, 4-28-10

enc:

Resumé - J.E. Randorff

Randorff and Associates Incorporated

June 2, 2010

Acoustical Assessment Report
Evaluation of Potential Noise Level Impact from
WalMart (proposed)
Rapid City, Pennington County, South Dakota

Page 13

ATTESTATION: I certify that to the best of my knowledge the data used in this report are true; that I have personally inspected the property described; and that I have no interest, present or prospective, therein. I certify the neither my employment nor fee is contingent on the conclusions contained in this report.

I certify that Randorff and Associates Incorporated is a member in good standing in the National Council of Acoustical Consultants. I certify that I have served on the Board of Directors of the National Council of Acoustical Consultants; have previously served as President; and presently serve as Chairman of the Professional Practice Committee.

As evidence of my qualifications to act as an independent consultant as regards this matter I enclose a copy of my resumé regarding environmental sound level assessment.

I understand that this report may be regarded as confidential and that I will not reveal its contents unless properly authorized to do so.

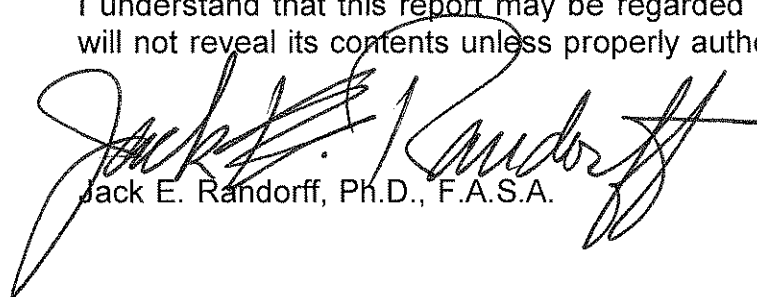

Jack E. Randorff, Ph.D., F.A.S.A.

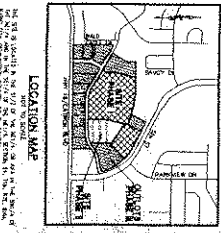
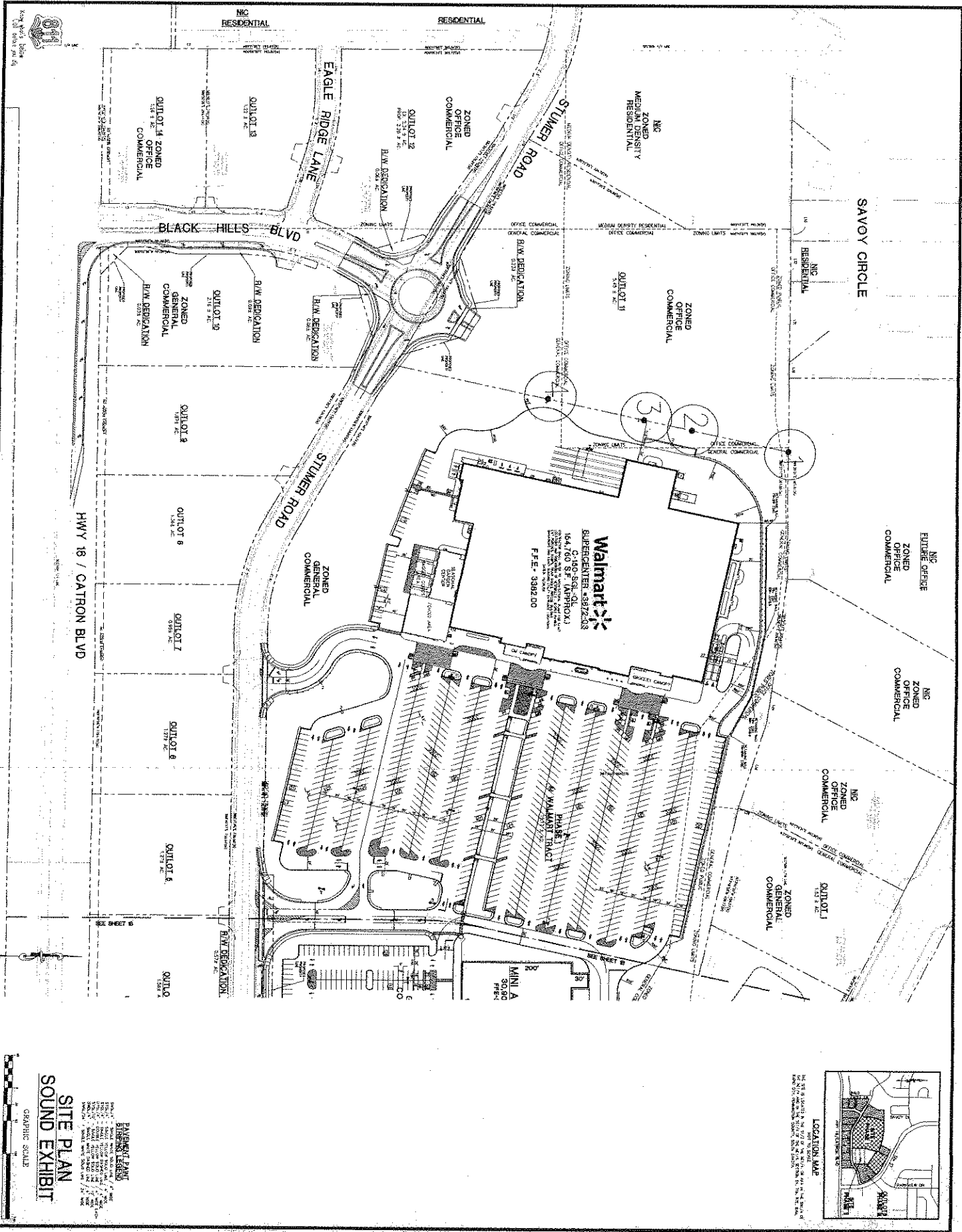

**SITE PLAN
 SOUND EXHIBIT**

GRAPHIC SCALE
 1" = 100'

PERMITS/FEES
 STATE OF SOUTH DAKOTA
 PLANNING AND ZONING DEPARTMENT
 1000 WEST 10TH AVENUE
 RAPID CITY, SD 57701
 (605) 328-2200
 WWW.PZ.SD.GOV

DATE: 04/21/2010
SCALE: 1" = 50'
DATE: 05/10/10
SCALE: 1" = 50'

PROPOSED BLACK HILLS CENTER
Walmart SUPERCENTER #3872-03
 RAPID CITY, PENNINGTON COUNTY, S.D.
 BY: THE STONERIDGE DEVELOPMENT, LLC
 ST. LOUIS, MO

W
Wolverton & Associates
 Consulting Engineers & Land Surveyors
 616 Boulder Parkway, Suite 100, Rapid City, SD 57701
 Phone: (605) 467-9999 • Fax: (605) 467-9071
 www.wolverton-associates.com

C-1A

WALMART-Rapid City, SD - 24-hr Sound Measurements
Position 1 - April 28, 2010

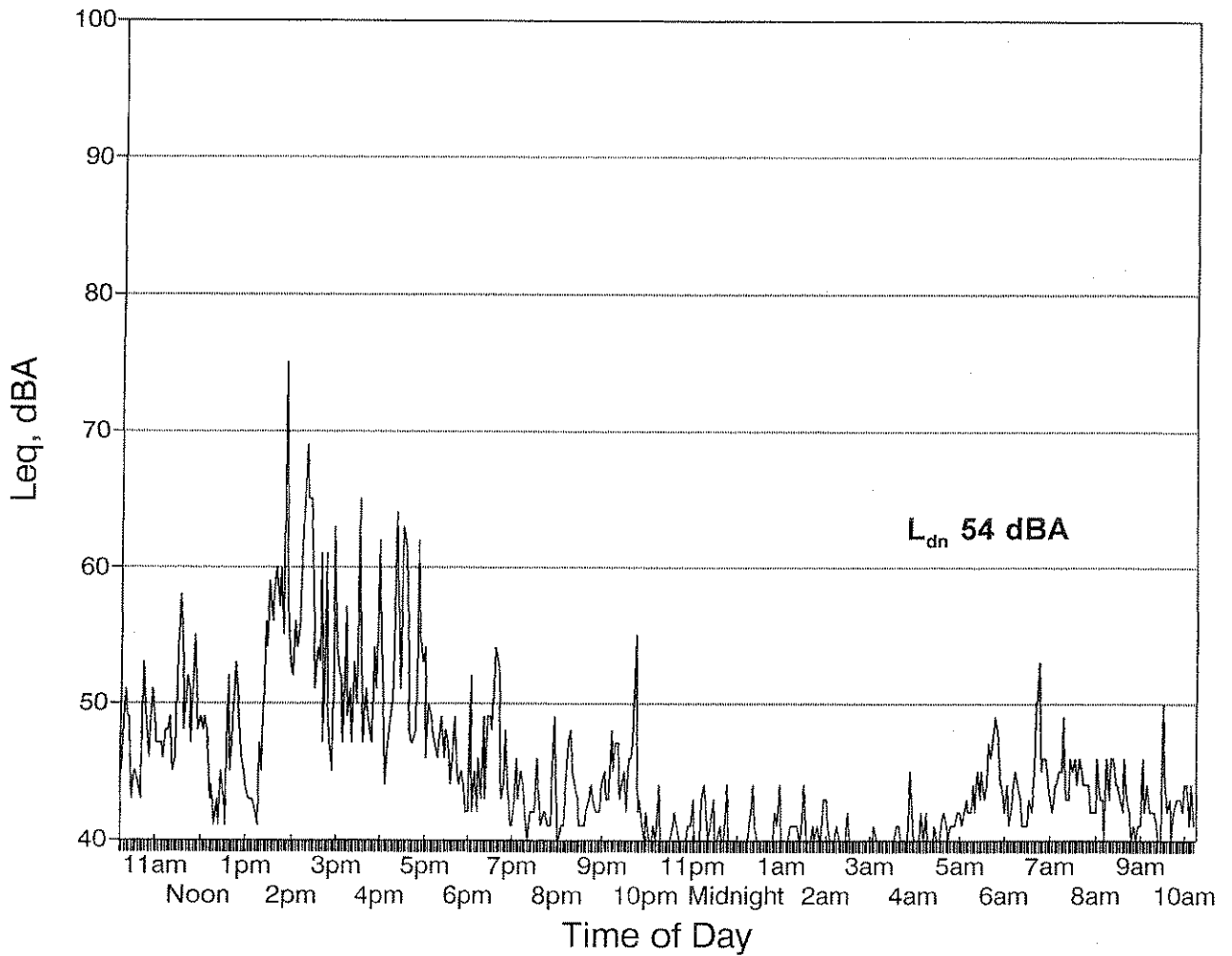

Figure 1. Sound level measurements at the northwest corner of the WalMart Supercenter commercially zoned property.



WALMART-Rapid City, SD - 24 hr Sound Measurements
Position 2 - April 28, 2010

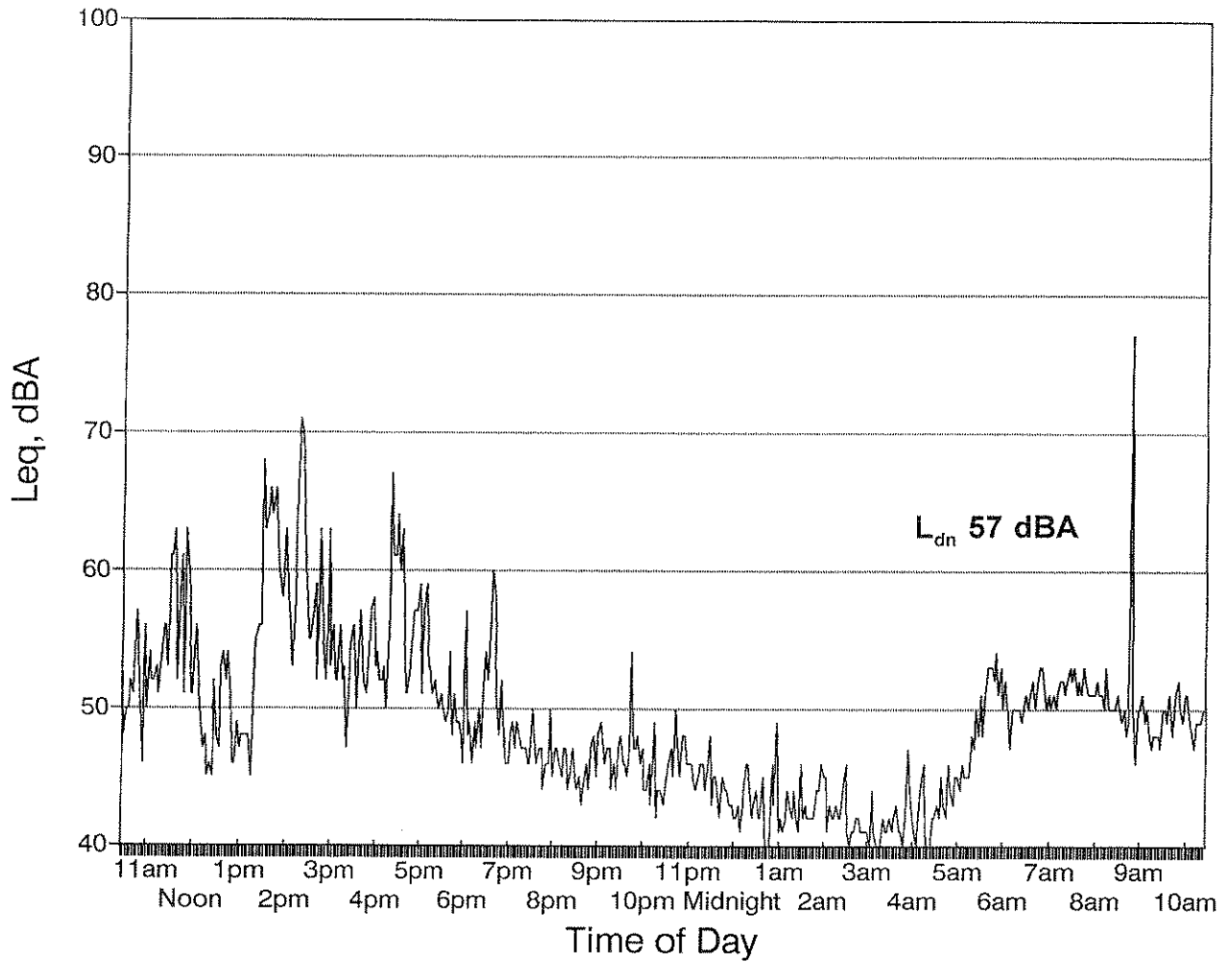

Figure 2. Sound level measurements on the west property line 190 feet south of the northwest corner of the WalMart Supercenter commercially zoned property.



WALMART-Rapid City, SD - 24 hr Sound Measurements
Position 3 - April 28, 2010

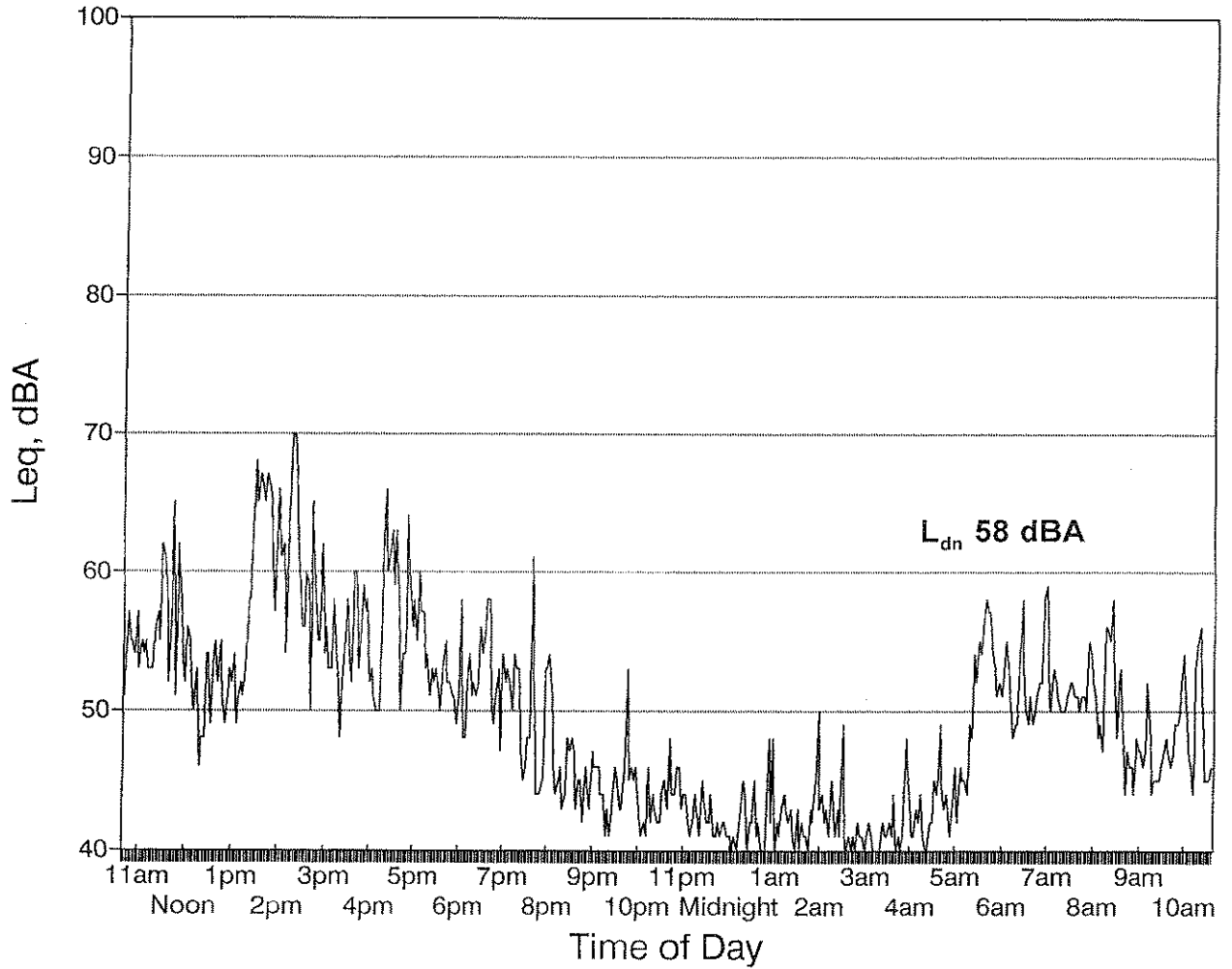

Figure 3. Sound level measurements on the west property line 280 feet south of the northwest corner of the WalMart Supercenter commercially zoned property.



WALMART-Rapid City, SD - 24 hr Sound Measurements
Position 4 - April 28, 2010

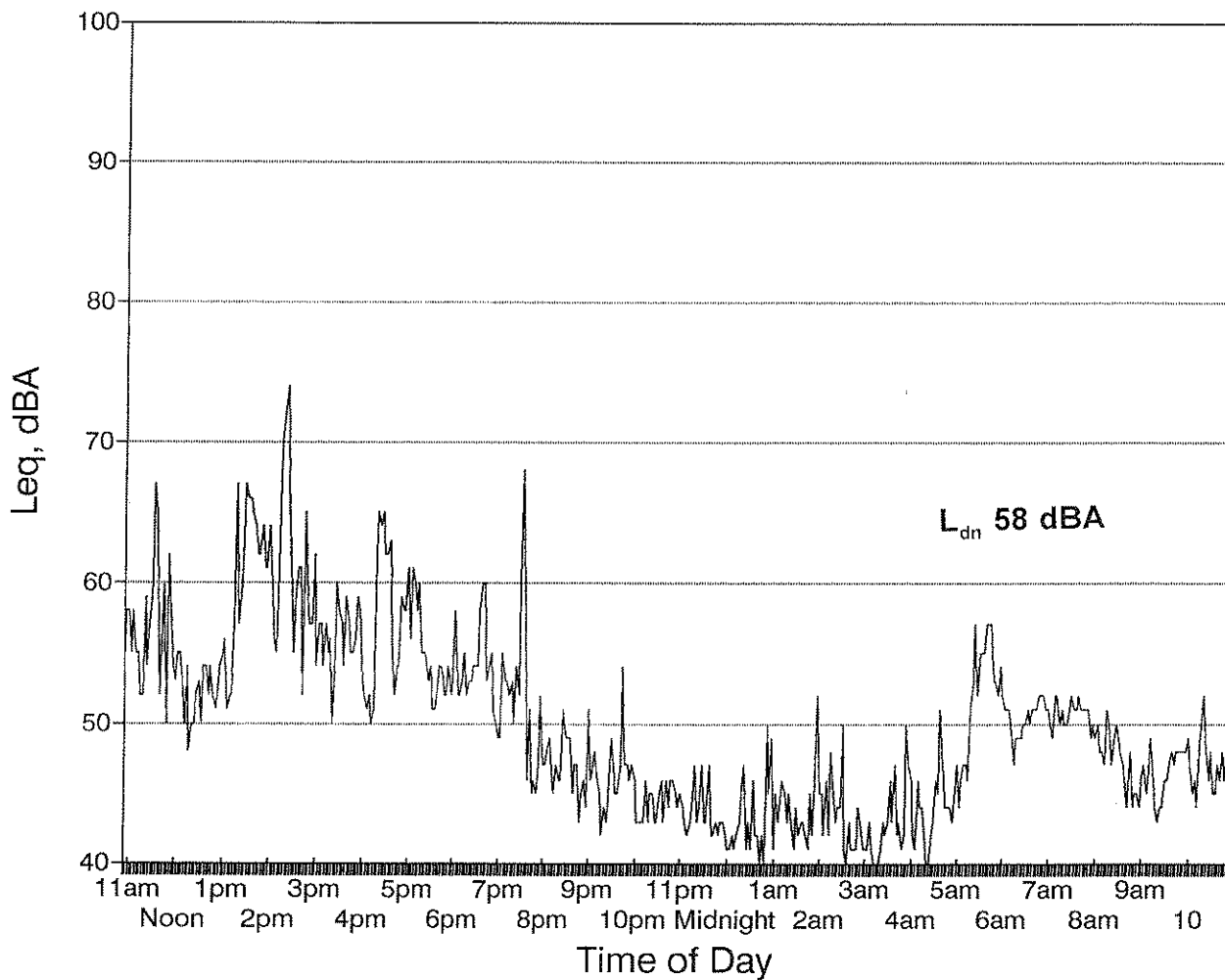

Figure 4. Sound level measurements on the west property line 480 feet south of the northwest corner of the WalMart Supercenter commercially zoned property.



JACK E. RANDORFF, Ph.D., F.A.S.A.

Environmental Noise Assessment and Control
Highway Noise Assessment and Abatement
Railway Noise Assessment and Abatement
Aircraft Noise Control
Noise Compatible Land Use

EDUCATION

Doctorate	Physics	1970	Texas Tech University
Master of Science	Physics	1967	Texas Tech University
Bachelor of Science	Physics	1965	Lamar University

PROFESSIONAL AFFILIATIONS

National Council of Acoustical Consultants - President 1992-1994
Vice President: Membership 1998-2002
Vice President: Finance 2002-2004
Chair: Professional Practices Committee 2004-2008

Engineers Council of Houston - President 1985-1986
Houston Chamber of Commerce - Education Committee 1982-1984
Acoustical Society of America - Fellow
American Institute of Physics
American Physical Society
Houston Engineering & Scientific Society
American Association of Physics Teachers

EXPERIENCE

President: 1978-Present / Randorff and Associates / Lubbock, Texas
(Formerly Acoustical Technologies Unit, Turner Collie & Braden Inc.)

Responsible for initiating and maintaining communications with present and prospective clients to determine needs and define engineering problems; responding to requests for proposals and presenting the firm's qualifications in the specialized area of acoustics. Provides technical guidance and coordinates administrative operations to ensure that assignments are completed to the client's satisfaction.

Prior experience includes 37 years in acoustics technology and active involvement in compatible development techniques regarding highway noise, rail noise, aircraft noise and environmental noise abatement; architectural acoustics; industrial noise and vibration control.

Background emphasizes the practical approach to problem solving as well as providing theoretical capability. Teamed with several professional colleagues to bring multi-disciplined capability to bear on large scale projects. Coordinated activities from concept and design through implementation and field execution to achieve workable solutions.



ACCOMPLISHMENTS

Provided environmental noise assessment and recommendations for:

- Dry Creek West Condominium, Austin, Texas.
- Quest Condominium, Austin, Texas.
- Apartment Building, 8501 Dryfield (Condominium Conversion), Austin, Texas.
- Hospital Corporation of America, Southwest General Hospital, Houston, Texas.
- Hayes Inc., Development Tracts, Port Arthur, Texas.
- Oak Park I, San Antonio, Texas.
- Newport Marriott, Newport, Rhode Island.
- The Thicket Apartments, Atlanta, Georgia.
- Texas A&M University, Cain Park, College Station, Texas.
- Courtyard by Marriott at Fossil Creek, Fort Worth, Texas.
- Residence Inn by Marriott at Airport Square, Anne Arundel County, Maryland.
- Marriott TownePlace Suites at Dulles Business Park, Fairfax County, Virginia.
- Courtyard by Marriott, Allentown/Bethlehem, Pennsylvania.
- Residence Inn by Marriott, Allentown/Bethlehem, Pennsylvania.
- Residence Inn by Marriott, Cary, North Carolina.
- Residence Inn by Marriott at Washingtonian Center, Gaithersburg, Maryland.
- Marriott TownePlace Suites, Richmond/Innsbruck, Virginia.
- University Park Subdivision, Irving, Texas.
- Studio Plus - Stemmons Freeway, Dallas, Texas.
- Residence Inn by Marriott - Rosemont/O'Hare, Rosemont, Illinois.
- Courtyard by Marriott at CharlesTowne Square, North Charleston, South Carolina.
- Village Oaks of Chapel Hill by Marriott, Chapel Hill, North Carolina.
- Thunderstorm Canine Search and Rescue, Abilene, Texas
- Courtyard by Marriott at Jersey Gardens, Elizabeth, New Jersey.
- Residence Inn by Marriott at Jersey Gardens, Elizabeth, New Jersey.
- Residence Inn by Marriott at Jersey Gardens, Elizabeth, New Jersey.
- Courtyard by Marriott, Warwick, Rhode Island.
- Residence Inn by Marriott, Southington, Connecticut.
- Springhill Suites by Marriott-Seattle Downtown, Seattle, Washington.
- Fairfield Inn & Suites-Austin Northwest, Austin, Texas.
- Hartford Marriott Downtown at Adriaen's Landing, Hartford, Connecticut.
- Office Building at 9430 Old Katy Road, Houston, Texas.
- Exstream Autoclean, Lubbock, Texas
- MARRIOTT Halifax Harborfront, Halifax, Nova Scotia, Canada
- Homewood Suites-Hilton at McClellan/Palomar Airport, Carlsbad, California
- Hampton Inn at McClellan/Palomar Airport, Carlsbad, California
- Residence Inn by Marriott, Tempe, Arizona
- Marriott Santa Ynez Valley, Buellton, California



Directed the site monitoring and environmental noise impact assessment for:

- IH610 Spur - IH610 to Crosstimbers, Texas SDHPT, District 12, Houston, Texas.
- Hardy Tollroad Interconnect at IH610, Texas SDHPT, District 12, Houston, Texas.
- Hardy Tollroad Interconnect at IH45, Texas SDHPT, District 12, Houston, Texas.
- Loop 336 South from FM2854 to IH45, Texas SDHPT, District 12, Conroe, Texas.
- Loop 336 South from IH45 to SH105, Texas SDHPT, District 12, Conroe, Texas.
- Loop 336 North Overpass Rehabilitation, Texas SDHPT, District 12, Conroe, Texas.
- Polk Street Bus Maintenance Facility, METRO, Houston, Texas.
- High-Capacity Transit Corridor, METRO, Houston, Texas.
- US59/Transitway from BW8 to SH6, Texas SDHPT, District 12, Houston, Texas.
- IH70/IH25 Interchange/Transitway, Colorado Dept. of Highways, Dist. 6, Denver, Colorado.
- US183 from SH71 to FM620, Texas SDHPT, District 14, Austin, Texas.
- Richmond Avenue Grade Separation, METRO/Dietrich Engineers Inc., Houston, Texas.
- Tidway Transit Center Ramp Connection, METRO, Houston, Texas.
- Kelley Steet & HOV Lane Connection, METRO, Houston, Texas.
- North Bus Operating Facility, METRO, Houston, Texas.
- West Covina Marriott, traffic impact, West Covina, California.
- Memorial Plaza Elderly Housing, traffic impact, Houston, Texas.
- Dry Creek Condominiums, traffic impact, Austin, Texas.
- Quest Condominiums, traffic impact, Austin, Texas.
- Warwick Condominiums, traffic and emergency vehicle impacts, Houston, Texas.
- Strang Yard, rail marshalling impacts, La Porte, Texas.
- St. Regis Corporation, rail impacts, Sartell, Minnesota.
- Champion International, rail impacts, Sartell, Minnesota.
- Lake Superior Paper Industries, community/industrial noise impacts, Duluth, Minnesota.
- New Harris County Jail, rail and traffic impacts, Houston, Texas.
- University Park Subdivision, rail impacts, Irving, Texas.
- Studio Plus - Stemmons Freeway, traffic impacts, Dallas, Texas.
- Courtyard by Marriott at Jersey Gardens, traffic, aircraft, and rail impacts, Elizabeth, New Jersey.
- Residence Inn by Marriott at Jersey Gardens, traffic, aircraft, and rail impacts, Elizabeth, New Jersey.
- Washington Gateway, Washington, D.C. (NE)
- Courtyard by Marriott (Eckington), 201 Florida Ave., Washington, D.C. (NE)

Directed the environmental noise impact assessment for:

- SH71 Proposed Grade Separation, Texas SDHPT, District 14, Austin, Texas.
- Hiram Clark Bus Maintenance Facility, METRO, Harris County, Texas.
- Peek Road/IH10 Interchange, Texas SDHPT, District 12, Houston, Texas.
- Mason Road/IH10 Interchange, Texas SDHPT, District 12, Houston, Texas.
- Grand Parkway from IH10 to US59, Texas SDHPT, District 12, Houston, Texas.



- Center Municipal Airport Expansion, Center, Texas.
- The Thicket Apartments, traffic impact, Atlanta, Georgia.
- Emerald Shapery Hotel, traffic and aircraft impacts, San Diego, California.
- Marriott at Market Center, traffic and aircraft impacts, Dallas, Texas.
- Red Lion Inn, traffic and light rail transit impacts, San Diego, California.
- Philadelphia Marriott Conshohocken, traffic and rail impacts, Philadelphia, Pennsylvania.
- Boca Raton Marriott at Crocker Center, rail impacts, Boca Raton, Florida.
- Ramada Renaissance - Greenway, rail impacts, Dallas, Texas.
- Miami Sofitel, aircraft impacts, Miami, Florida.
- Pittsburgh Airport Marriott, aircraft impacts, Pittsburgh, Pennsylvania.
- Emerald Shapery Center, aircraft impacts, San Diego, California.
- Houston Studios Movie Sound Stage, traffic, aircraft, and rail impacts, Houston, Texas.
- Courtyard by Marriott at Fossil Creek, traffic impacts, Fort Worth, Texas.
- Residence Inn by Marriott at Airport Square, aircraft impacts, Anne Arundel County, Maryland.
- Marriott TownePlace Suites at Dulles Business Park, aircraft impacts, Fairfax County, Virginia.
- Courtyard by Marriott, aircraft impacts, Allentown/Bethlehem, Pennsylvania.
- Residence Inn by Marriott, aircraft impacts, Allentown/Bethlehem, Pennsylvania.
- Residence Inn by Marriott, aircraft impacts, Cary, North Carolina.
- Residence Inn by Marriott at Washingtonian Center, traffic impacts, Gaithersburg, Maryland.
- Marriott TownePlace Suites, mechanical noise impact, Richmond/Innsbruck, Virginia.
- Residence Inn by Marriott - Rosemont/O'Hare, aircraft impacts, Rosemont, Illinois.
- Courtyard by Marriott at CharlesTowne Square, aircraft impacts, North Charleston, South Carolina.
- Village Oaks of Chapel Hill by Marriott, mechanical noise impact, Chapel Hill, North Carolina.
- Coronado Area Neighborhood Association, noise impact of Marsha Sharp Freeway by Texas Department of Transportation, Lubbock, Texas.
- Office Building at 9430 Old Katy Road, noise impact of IH-10 Expansion by Texas Department of Transportation, Houston, Texas.
- Exstream Autoclean, noise impact assessment and abatement recommendations for reduction of neighborhood noise, Lubbock, Texas

Studied, analyzed and provided expert testimony for the Highway Division of the Office of the Attorney General of the State of Texas, the County Attorney for Harris County, Texas or the protesting defendants for condemnation proceedings involving environmental noise exposure from highway traffic in the following cases:

- State of Texas v. San Antonio Savings Association, 1990, Travis County.
- State of Texas v. Amberjack Ltd; et al., 1992, Travis County.
- Donald Glenn Felts and Mary Taylor Felts v. Harris County, Texas, 1991, Harris County.
- State of Texas v. Lakehills Cinema, Ltd., et al., 1992, Travis County.



- State of Texas v. Interstate Northborough Partnership, et al., 1992, Harris County.
- State of Texas v. Seatree I Limited Partnership, et al., 1996, Harris County.
- Harris County v. Crown Plaza Group, et al., 1989, Harris County.
- State of Texas, et al. v. Sabretree Associates Limited Partnership, 1991, Travis County
- State of Texas v. Herbert Guy Purtle, et al, 1991, Travis County.
- State of Texas v. Sherman S. Cho, 1992, Harris County.
- State of Texas v. American National Insurance Company, 1994, Harris County.
- State of Texas v. Amberjack Ltd; et al., 1992, Travis County.
- State of Texas v. First Gibraltar, FSB, et al., 1992, Travis County.
- State of Texas v. First Gibraltar Bank, FSB, f/k/a Gibraltar Savings, 1995, Harris County.
- State of Texas v. Society of St. Pius X Queen of Angels Chapel, 1992, Galveston County.
- State of Texas v. Northborough Center, Inc., et al., 1992, Harris County.
- State of Texas v. Shaner Suite Hotels, L.P., et al., 1994, Travis County.
- State of Texas v. MMB-1, Ltd., 1994, Harris County.
- State of Louisiana, Department of Transportation & Development v. Calvary Baptist Church of Vienna, Louisiana.

Studied, analyzed and provided expert testimony for the litigation involving environmental noise exposure from various sources in the following cases:

- Mr. and Mrs. George Poindexter v. Fiesta Mart, Inc., 1992, Harris County, Texas (District Court).
- Gregory S. Bloom, Marianne F. Bloom, William R. Stratton, Robert A. Bianchi, et al. v. Southern Pacific Transportation Company, 1997, Ventura County, California (Superior Court).
- Alice Voorhies v. Petro Rentals, Inc., 1997, Lafayette Parish, Louisiana (District Court).
- Citizens v. Woodward Inc., 1973, Travis County, Texas (District Court).
- School Districts of Los Angeles, El Segundo, Lennox, Inglewood v. City of Los Angeles Airport Board, 1975, Los Angeles, California (District Court).
- Emile Jamail v. City of Austin, 1982, Travis County, Texas (District Court).
- Harrison Properties v. Texas Air National Guard/Crystal MOA proposed changes, 1987, Carrizo Springs, Texas (District Court).
- Pirates Property Owners Association v. Cabot Petroleum Corporation, 1989, Galveston, Texas (District Court).
- City of Lockhart v. Terrell T. McGee, et ux, and et al., 1991, Caldwell County, Texas (County Court).
- Summit Court Owners Association v. Kensington Green Apartments Ltd., 1990, Harris County, Texas (District Court).
- George Stewart, et al. v. Newsprint South, Incorporated, et al., 1992, U.S. District Court, Northern District of Mississippi, Western Division.
- Joe Frazier and Terry Frazier, et al. v. Newsprint South, Incorporated, et al., 1992, U.S. District Court, Northern District of Mississippi, Western Division.
- Del Valle Independent School District v. City of Austin, Airport Department, 1996, Travis County, Texas (Negotiated Settlement).



- DeWitt Thomas et ux v. Union Pacific Resources Company, 1997, Jasper County, Texas (District Court).
- East Sixth Street Community Association, et al. v. City of Austin, Texas, 1998, Travis County, Texas (County Court at Law).
- Suetrack U.S.A Company v. Ross Perot, Jr., Hillwood Development Corporation d/b/a The Perot Group, and Charles Willis & Associates, Inc., 1992, Denton County, Texas (District Court).
- Marjorie N. Akers, et al. v. Union Pacific Railroad Company, Rail Unlimited, Inc. & Hadley Auto Transport Company, 1999, Houston, Texas (U.S. District Court).
- Jonathan Callaway, Shannon Callaway, Jeffry McKee, David Christensen and Doreen Christensen v. Timothy Slattery, Sheila K. Slattery, and Erin C. Enterprises, Inc., DBA North Texas Hunting Retriever Training Center, 2003, Collin County, Texas (District Court).
- Energy Transfer Fuel, L.P. v. Cecil C. Wilson and wife, Sara E. Wilson, 2006, Denton County, Texas (County Court at Law).
- Russell Howard and Joan Howard, et al. v. Samson Investment Company, Sampson Lone Star Limited Partnership, Jimmy E. Trlicek, Landry Services, Inc., Temple-Inland Forest Products Corporation, and GMAC Global Relocation Services, Inc., 2006, Jefferson County, Texas (Judicial District Court).
- Danny D. Cole and Kay C. Cole v. Barnett Gathering LP; XTO Resources I GP, LLC; Walsh Ranches Limited Partnership and Walsh North Star Company, 2007, Parker County, Texas (Judicial District Court).
- David Comte and Patricia Comte v. Enbridge Pipelines (East Texas) L.P., 2007, Rusk County, Texas (Judicial District Court).
- Bill Guthrie and Carolyn Guthrie v. Atmos Energy Corporation; Energy Transfer Fuel L.P.; Energy Transfer Fuel GP, LLC; Enbridge Gathering (North Texas), LP; Enbridge Pipelines (North Texas), LP; Enbridge Holdings (Texas System) LLC, 2007, Denton County, Texas (Judicial District Court).
- Jim Caplinger and Judy Caplinger v. Atmos Energy Corporation; Energy Transfer Fuel L.P.; Energy Transfer Fuel GP, LLC; Enbridge Gathering (North Texas), LP; Enbridge Pipelines (North Texas), LP; Enbridge Holdings (Texas System), LLC. 2007, Denton County, Texas (Judicial District Court).
- Jennifer De La Cruz and R.J. Harvell v. CrossTex CCNG Processing, Ltd., CCNG Inc., CrossTex Energy Services, L.P., and CrossTex Energy Services GP, LLP. and CrossTex Operating GP, LLC, 2008, Parker County, Texas (Judicial District Court).
- Lloyd Burgess and Rhonda Burgess v. Atmos Energy Corporation; Energy Transfer Fuel L.P.; Energy Transfer Fuel GP, LLC; Enbridge Gathering (North Texas), LP; Enbridge Pipelines (North Texas), LP; Enbridge Holdings (Texas System) LLC, 2008, Denton County, Texas (Judicial District Court).
- Joey Courtney v. Energy Transfer Partners, L.P., Energy Transfer Equity, L.P., and Houston Pipe Line Co., L.P., 2009, Angelina County, Texas (Judicial District Court).



Provided technical support and consultation in the preparation of:

- City of Houston, Texas - Section 2 of Ordinance No. 93-77, adopted January 20, 1993, amending Chapter 30 of the Code of Ordinances - Noise and Sound Level Regulation.
- City of Port Arthur, Texas - Draft Noise Control Ordinance

Managed and reviewed the environmental noise impact assessment for:

- Dallas/Fort Worth International Airport Master Plan Update.
- U.S. Navy Gulf Coast Homeporting.
- Houston Intercontinental Airport, Compatible Land Development Uses (as team member of the Engineers of the Southwest, for the Houston Department of Aviation).

Directed site specific environmental noise impact assessment for:

- Aircraft Noise Impact from Robert Mueller Municipal Airport, City of Austin, Texas.
- Aircraft Noise Impact from Austin-Berstrom International Airport, Austin, Texas.
- Nightclub Noise Impact and Sound Level Measurements by Austin Municipal Code.

Prior to forming Randorff and Associates, served as either senior consultant, principal noise control investigator, or co-investigator for:

- Federal Highway Administration: Highway Noise Model Review.
- U.S. Department of Housing and Urban Development: 24 CFR Part 51.
- Highway Noise Assessment, Caddo Parish School District, Shreveport, Louisiana.
- Federal Aviation Administration: FAR Part 36/small aircraft sound level regulations.
- Los Angeles International Airport: Schools Noise Abatement.
- Dallas/Fort Worth Airport; Draft Compatible Development Regulations.
- Airport Compatible Development Regulations presentations for:
 - City of Arlington
 - City of Flower Mound
 - City of Irving
 - City of Coppell
 - City of Grand Prairie
 - City of Lewisville
 - City of Euless
 - City of Grapevine
 - City of Southlake
- Tulsa County Fairgrounds, Tulsa, Oklahoma: Automobile Race Track.
- City of Abilene, Texas: Noise Control Ordinance Draft.
- Highway Noise Assessment, Mingo School District, Tulsa, Oklahoma.

PUBLICATIONS

"Acoustical Engineering II: Applications for Historic Preservation Projects", Texas Architect Continuing Education Supplement, March/April 1999.

"Practical Applications in Acoustical Engineering", Texas Architect Continuing Education Supplement, March/April 1998.



"Acoustics in Corrections - A Practical Guide for Administrators and Planners", ed., Committee on Acoustics in Corrections, 1994.

"Acoustical Testing of the Astrodome - An Update", with C. Reinhardt, Sound and Vibration, October 1992.

"Noise Control - Selling Your Proposal to Management", Industrial Safety & Hygiene News, October 1990.

"Astrodome Undergoes Sound System Changeover", with D. E. Marsh and A. Taylor, Sound & Video Contractor, February 20, 1990.

"Researching The Astrodome's Acoustics", with D. E. Marsh and A. Taylor, Sound & Video Contractor, February 20, 1990.

"Lake Superior Paper Engineers Mill to Minimize Noise in Its Community", with R. R. Spillman and S. J. Semenchuk, Pulp & Paper, January 1990.

"Machinery Protection Through Vibration Monitoring", with R. R. Spillman and T. J. Rolan, Public Works, October 1989.

"Printing Plant Personnel Noise Exposure Control", with R. Q. Small, American Industrial Hygiene Conference, 1988.

"Acoustical Testing of The Astrodome", with J. A. Taylor, Sound and Vibration, October, 1988.

"A Recent Study of Sound Systems and Acoustics in The Astrodome", with J. A. Taylor and D. E. Marsh, Eighty-Fifth Convention of the Audio Engineering Society, Los Angeles, 1988.

"Noise Reduction to a Community Adjoining a Large Pulp and Paper Mill", with R. R. Spillman, American Industrial Hygiene Conference, 1988.

"Industrial Silencer Case Study in Paper Industry Application - Special Design for Exhaust from Manifold of Eleven Large Vacuum Pumps Totaling 4,500 Hp", with E. J. Halter and R. R. Spillman, ASME Industrial Pollution Control Symposium, 1985.

"Methodology of Developing and Gaining Acceptance of Regulations for Land Development Near a Major Airport", Inter-Noise 74 Proceedings, 1974.

"Numerical Approximation of Experimental Values", with T. Atchison, Texas Journal of Science, Vol. 22, No. 4, 1971.

"Acoustic Studies of Superconducting Single-Crystal Lead", Doctoral Dissertation, Texas Tech University, 1970.



PRESENTATIONS

"Speaking of Hotel Acoustics", a continuing education seminar at the Marriott International Western Region Engineers' Annual Conference, San Francisco, California, April 2004.

Chairman & Producer-FORENSIC ACOUSTICS SEMINAR, co-sponsored by the Acoustical Society of America and the National Council of Acoustical Consultants, Austin, Texas, November 14, 2003.

"Audibility of Locomotive Horns Inside Highway Vehicles Near Highway-Railroad Grade Crossings", 146th Meeting Acoustical Society of America, Austin, Texas, November 2003.

Chairman-Session on Architectural Acoustics, Noise and Speech Communications: Forensic Acoustics II, 146th Meeting Acoustical Society of America, Austin, Texas, November 2003.

Chairman-Session on Architectural Acoustics, Noise and Speech Communications: Forensic Acoustics I, 146th Meeting Acoustical Society of America, Austin, Texas, November 2003.

"Engineering Challenges of the Acoustics of a Political Convention", 143rd Meeting, Acoustical Society of America, Pittsburgh, Pennsylvania, June 2002.

"Community Noise Reduction Through Sound System Renovation: A Case Study", 140th Meeting, Acoustical Society of America, Newport Beach, California, December 2000.

"Lessons Learned: Acoustics", The Link 2000 - Design & Construction Conference, hosted by Marriott International, Chantilly, Virginia, September 2000.

"Electronic Gavel at the 2000 Republican National Convention", Interview with Robert Siegel on National Public Radio (NPR) All Things Considered by Linda Wertheimer, Philadelphia, Pennsylvania, August 2000.

"Acoustics of the 2000 Republican National Convention", Interview with Cable News Network (CNN) for Nightly News with Judy Woodruff, Philadelphia, Pennsylvania, August 2000.

Chairman-Session on Architectural Acoustics: Stadium and Arena Acoustics, 139th Meeting, Acoustical Society of America, Atlanta, Georgia, May 31, 2000.

"Acoustics of Political Conventions-A Review, 139th Meeting, Acoustical Society of America, Atlanta, Georgia, May 2000.

"Practical Applications in Acoustical Engineering", Houston Chapter/American Institute of Architects, Houston, Texas, September 1999.

"Brand Acoustical Study: Presentation of Findings", The Link - Design & Construction



Conference, hosted by Marriott International, Chantilly, Virginia, June 1999.

"Acoustically Speaking", Texas Society of Architects 59th Annual Convention, Austin, Texas, October 1998.

"Practical Applications in Acoustical Engineering", Brazos Chapter/American Institute of Architects, Bryan/College Station, Texas, September 1998.

"Noise - The #1 Guest Complaint", The Link - Design & Construction Conference, hosted by Marriott International, Bethesda, Maryland, June 1998.

"The Role of Acoustics in Higher Education", Texas Association of Physical Plant Administrators, TAPPA '98, Bryan/College Station, Texas, April 1998.

"Noise Reduction for a Community Adjoining A Large Pulp and Paper Mill: A Case Study in Industrial Noise Control", Texas Tech University Mechanical Engineering Department, Lubbock, Texas, March 1996.

"Acoustical Studies of the Astrodome, Including Special Treatment Techniques Used During The 1992 Republican National Convention", Texas Tech University College of Architecture, Lubbock, Texas, March 1996.

"Acoustic Design Guide for Corrections Facilities", Committee on Technology and Design of the American Correctional Association, ACA Winter Conference, Orlando, Florida, 1994.

"Noise Control Design and Implementation for a New Pulp and Paper Mill - A Case Study", 114th Winter Annual Meeting, American Society of Mechanical Engineers, New Orleans, Louisiana, 1993.

"Acoustics 101: Everything the Facility Manager Needs to Know About Acoustics" - A Panel Discussion for the International Association of Arena Managers, Dallas, Texas, 1993.

"A Brief Case Study: Traffic Noise Attenuation Across Open Terrain for a Rural State Highway", Transportation Research Board Committee A1F04 Summer Meeting, Berkeley, California, 1993.

"Airport Noise - Fact or Fiction", Texas Airport Operators Conference, Austin, Texas, 1992.

"1992 Republican Convention: Acoustics at the Astrodome", Interview with Cable News Network (CNN) Science & Technology Weekly Program, Houston, Texas, August 1992.

"Remaking the Acoustics of the Astrodome for the 1992 Republican Convention", Interview with C-Span, Houston, Texas, August 1992.



"Acoustical Testing of the Harris County Domed Stadium (The Astrodome)", 119th Meeting, Acoustical Society of America, State College, Pennsylvania, 1990.

"The Technical Person as Leader: Problems and Solutions", Houston Baptist University, Houston, Texas, 1990.

"Selling Noise Control to Your Corporation", American Industrial Hygiene Conference, Orlando, Florida, 1990.

"Noise Reduction for Process and Power Plants", Eighth Annual Convention, Society of Piping Engineers and Designers, Houston, Texas, 1989.

"Acoustics in Practice: A Perspective", Department of Natural Sciences, University of Houston-Downtown, Houston, Texas, 1988.

"Beyond the Workplace", Houston Area Section/Society of Women Engineers, Houston, Texas, 1985.

"Architectural Acoustics", 45th Annual Meeting - Texas Society of Architects, Houston, Texas, 1984.

"Acoustical Engineering - Practical Applications for Architectural Projects", Houston Chapter/American Institute of Architects, Houston, Texas, 1984.

"ECO Burnout" - Panel Discussion Telecast by KUHT, Channel 8 Television, Houston, Texas, 1982.

"Acceptance Testing and Acoustical Standards", Construction Specifications Institute, Houston, Chapter, Houston, Texas, 1982.

"Industrial Noise Control", American Society of Safety Engineers, Gulf Coast Chapter, Houston, Texas, 1980.

"Roundtable - Community Noise/Regulation and Enforcement", Eighth Annual Short Course for Planning Commissioners and Elected Officials, American Planning Association, Texas Chapter, Houston, Texas, 1979.

"Discussion - Community Noise Abatement", Seventh Annual Short Course for Planning Commissioners and Elected Officials, American Institute of Planners, Texas Chapter, Houston, Texas, 1978.

"Air and Noise Pollution Requirements for Cities", Clinic, Texas Municipal League, Annual Conference, Fort Worth, Texas, 1978.



"Noise Control for Reciprocating and Rotating Equipment", Gulf Coast Compression Roundtable, University of Houston Continuing Education Center, Houston, Texas, 1977.

"Industrial Noise Control," American Institute of Plant Engineers, Gulf Coast Chapter, Houston, Texas, 1977.

"Airport/Aircraft Noise Assessment" - Talk Show Interviews, KPRC-950 Radio, Houston, Texas, 1976.

"Noise Control for Reciprocating and Rotating Equipment", American Society of Mechanical Engineers, Northwest Houston Chapter, Houston, Texas, 1976.

"Noise Control in the Gas Process Industry", Gas Processors Association, New Orleans Regional Meeting, New Orleans, Louisiana, 1976.

"College Campus Designed for Compatible Coexistence With a Major Airport", 89th Meeting, Acoustical Society of America, Austin, Texas, 1975.

"Noise Control Engineering Seminar", American Institute of Industrial Engineers, Shreveport Chapter, Shreveport, Louisiana, 1974.

"Perspective on Engineering Noise Control", American Society of Safety Engineers, Southwest Chapter, Dallas, Texas, 1974.

"Noise Control Engineering in Practice", 35th Annual Texas Safety Conference and Exposition, Texas Safety Association, Dallas, Texas, 1974.

"Noise Pollution", Man and Environment Lecture Series, KERA, Channel 13 Television, Dallas, Texas, 1974.

"Methodology of Developing and Gaining Acceptance of Regulations for Land Development Near a Major Airport", Inter-Noise, Washington, D.C., 1974.

"New Approaches in Developing Regulations for Land Development Near a Major Airport", 86th Meeting, Acoustical Society of America, Los Angeles, California, 1973.



BN-ACCTB0207
February 2007

BOHN

THE COLD STANDARD

AIR-COOLED CONDENSERS

Technical Guide

Monarch™ and Ambassador™ Series



TABLE OF CONTENTS

Overview	2, 3
Features & Options	3, 4
Three Solutions	5
Nomenclature.....	6
Condenser Selection Procedure	7-9
Ambassador™ Series	
540 RPM	10-11
830 RPM	12-15
Monarch™ Series	
EC Selection.....	16
Sound Data.....	16
Energy Comparison.....	17
Capacities.....	18
Specifications.....	19

1140 RPM Series	
Features & Options	20
Capacities.....	21
Specifications.....	22
Dimensions.....	23
Fan Cycling.....	24-25
Control Panels for Electronic Controllers	26
Condenser Refrigerant Charge.....	26-28
Calculate Refrigerant Charge.....	28
Typical Condenser Wiring Diagrams	29-30
Sound Data.....	31



OVERVIEW

The Bohn Monarch and Ambassador Series of direct drive air-cooled condensers incorporate the latest advancements in condenser technology to provide the quietest and most efficient condensers in the industry.

Monarch™ Series *Optimized sound and energy performance.*

The Monarch Series of condensers by Bohn offers the optimum solution for sound and energy performance. The Monarch Series utilizes EC motor technology, which provides unmatched sound and energy performance and is the perfect solution for those applications where low noise levels and significant energy savings are essential for success.

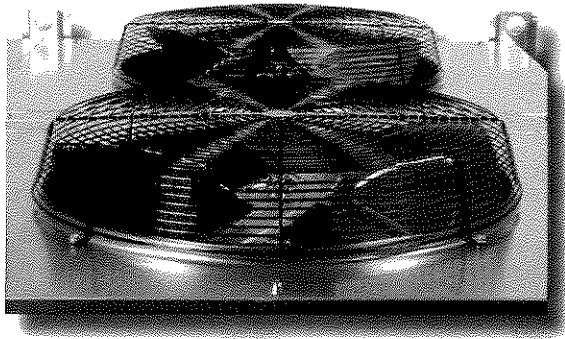

Since product improvement is a continuing effort, we reserve the right to make changes in specifications without notice.

Ambassador™ Series *Excellence in sound, energy and capacity solutions.*

The Ambassador Series of condensers by Bohn is designed specifically with the growing needs of the supermarket and grocery industry in mind. This series utilizes 830 and 540 RPM motors and incorporates advanced features that further improve sound levels and energy efficiencies, as well as provide increased capacity in a smaller footprint. In addition, there are new features designed to improve serviceability, resulting in reduced maintenance costs.

The Ambassador Series is a perfect fit for applications requiring low sound and energy levels and optimized capacities.

1140 Series

Bohn continues to offer the 1140 RPM Series for customers seeking the most economical solution for their capacity requirements.

Bohn condensers now incorporate a broader product range with capacities ranging from 11 to 265 nominal tons to address all applications.

All Bohn condenser coils incorporate the Floating Tube™ coil design, which virtually eliminates the possibility of tube sheet leaks. Condenser coils are designed for maximum heat transfer and are designed to operate with CFC-free refrigerants.

OVERVIEW (continued)

As with all Bohn products, extensive testing of the condenser ensures long and trouble-free service life.

The condensers are designed for outdoor application with housings available in aluminum finish and painted or unpainted galvanized steel.

The condensers are available in either single or double wide fan configurations.

The condenser design incorporates the features most desired in air-cooled condensers. An extensive list of options and fan cycle control panels complement the condenser design and allow the condenser to match the most rigid application requirements.

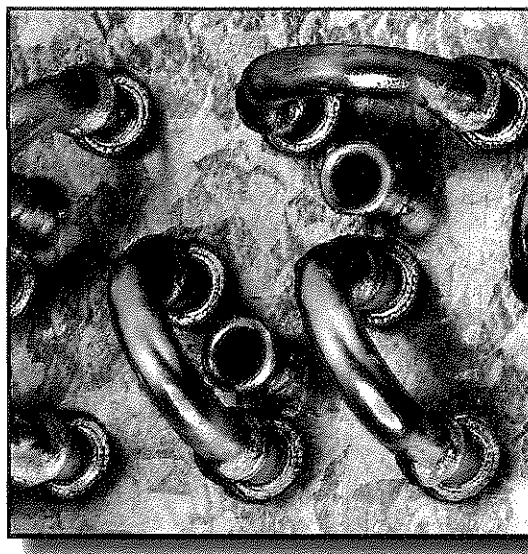

The Floating Tube™ Coil Design
Dramatically Reduces Tube Sheet Leaks

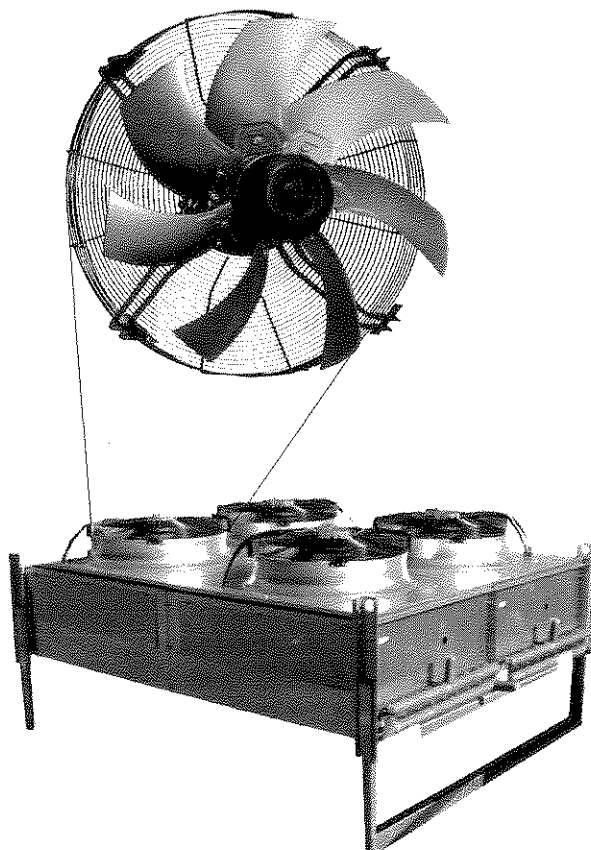

Monarch™ Series with EC Motor Technology

FEATURES

Bohn's latest air-cooled condenser is available in multiple product tiers and are designed with features to meet exacting customer requirements.

Bohn Monarch™ Series of Condensers

Customers seeking optimum sound and energy performance can select the Bohn Monarch Series of condensers with EC motor technology. EC motors provide unparalleled sound and energy performance.

Features include:

- EC motor, swept fan blade and venturi incorporating integrated variable speed technology
- Broad capacity range from 16 to 264 tons
- Aluminum housing for an attractive appearance and corrosion protection, with painted galvanized steel, or galvanized steel available as an option
- Side access panels allow for ease of cleaning coils

Bohn Ambassador™ Series of Condensers

The Ambassador Series by Bohn is designed specifically with the growing needs of the supermarket and grocery industry in mind. This series utilizes 830 and 540 RPM motors and incorporates advanced features that further improve sound levels and energy efficiencies as well as provide increased capacity in a smaller footprint. In addition, there are new features designed to improve serviceability, resulting in reduced maintenance costs. The Ambassador Series is a perfect fit for applications requiring low sound and energy levels and optimized capacities.

Features include:

- Direct drive fan motors in 830 or 540 RPM
- The patented QuietEdge™ fan blade provides an unprecedented sound level of 49.6 dBA (540 RPM @ 10 ft.)
- Bohn's patent-pending ServiceEase™ motor mount feature, allows for ease of motor service and reduces likelihood of damage to the coils during servicing
- Bohn condenser coils incorporate the latest advancements in coil technology to provide maximum capacity
- Broader product range to address all applications — capacities ranging from 11 to 225 nominal tons
- Galvanized steel cabinet with the option for aluminum or painted galvanized steel
- High efficiency, three-phase fan motors with ball bearings and internal overload protection

1140 Series

For customers seeking an economical solution to their capacity needs, Bohn now offers the 1140 RPM Series with enhancements to improve capacity and serviceability.

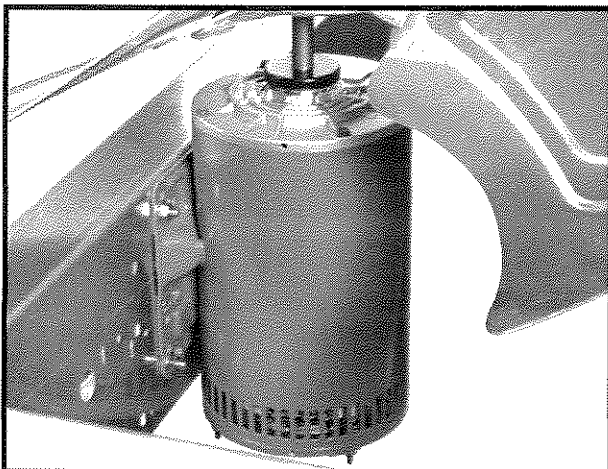

ServiceEase™ Motor Mount System

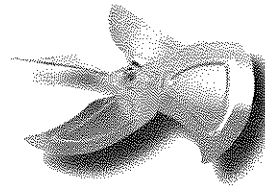

Bohn's Patented QuietEdge™ Fan Blade for Improved Sound Performance

Features include:

- Direct drive fan motors
- Bohn's patent-pending ServiceEase™ motor mount
- New, high efficiency condenser coil designed for optimum performance
- Expanded product range from 15 to 249 nominal tons
- Galvanized steel as a standard housing, with an option for aluminum or painted galvanized steel
- High efficiency, three-phase fan motors with ball bearings and internal overload protection

All Standard Condensers

- 10 fins per inch spacing
- Modular design with models in both single and double wide fan configurations
- All Bohn condensers incorporate the Floating Tube™ coil design, which virtually eliminates tube sheet leaks
- Internal baffles provided between all fan cells
- Condensers up to 3 fans in length use 3/8" diameter tube to minimize refrigerant charge. Condensers 4 or more fans in length use 1/2" diameter tube to minimize refrigerant pressure drop
- Coated steel fan guards
- Weatherproof control panel with factory-mounted door interrupt disconnect switch
- UL and UL listed for Canada

Available Options:

- Multi-circuiting at no additional charge
- Optional 8, 12 or 14 FPI spacing
- Fan-cycle control panels
- Alternate coil construction including BohnGuard™ coated fins, epoxy or phenolic coated fins and copper fins
- Hinged fan panels for ease of servicing (Ambassador and 1140 Series only)
- Side access panels
- Extended condenser legs for increased ground clearance
- Sealtite wiring
- Frame for shipping

Three solutions tailored to fit your unique needs.

Choose from the Monarch, Ambassador or 1140 Series of air-cooled condensers by Bohn. Choosing the Monarch Series means you have an unmatched solution for capacity, sound and energy efficiency while the Ambassador Series offers excellence in capacity, sound and efficiency. Bohn continues to offer the 1140 RPM Series to meet high capacity needs without concerns for low sound and high efficiency.

FEATURE	1140 SERIES	AMBASSADOR SERIES	MONARCH SERIES
Motors			
<i>Standard Motor</i>	<i>1140 RPM</i>	<i>830, 540 RPM</i>	<i>Variable Speed EC Motors</i>
<i>P66 Motor Option</i>	✓	✓	<i>(not required)</i>
Cabinet			
<i>Standard Cabinet</i>	<i>Galvanized</i>	<i>Galvanized</i>	<i>Aluminum</i>
<i>Galvanized Option</i>	<i>(standard)</i>	<i>(standard)</i>	✓
<i>Pre-Painted Galvanized Option</i>	✓	✓	✓
<i>Aluminum Option</i>	✓	✓	<i>(standard)</i>
Venturi Cover			
<i>Standard Venturi</i>	<i>Removeable</i>	<i>Removeable</i>	<i>EC Tall Optimized</i>
<i>Hinged Option</i>	✓	✓	-
Fan Blades			
<i>Standard Blade</i>	<i>Standard</i>	<i>QuietEdge™</i>	<i>EC Optimized</i>
Motor Mount			
<i>Standard Motor Mount</i>	<i>ServiceEase™</i>	<i>ServiceEase™</i>	<i>EC Optimized</i>
Warranty			
<i>2-Year Warranty</i>	✓	✓	✓
<i>3-Year Warranty — EC Motors</i>	-	-	✓
<i>5-Year Warranty — Floating Tube™</i>	✓	✓	✓

NOMENCLATURE

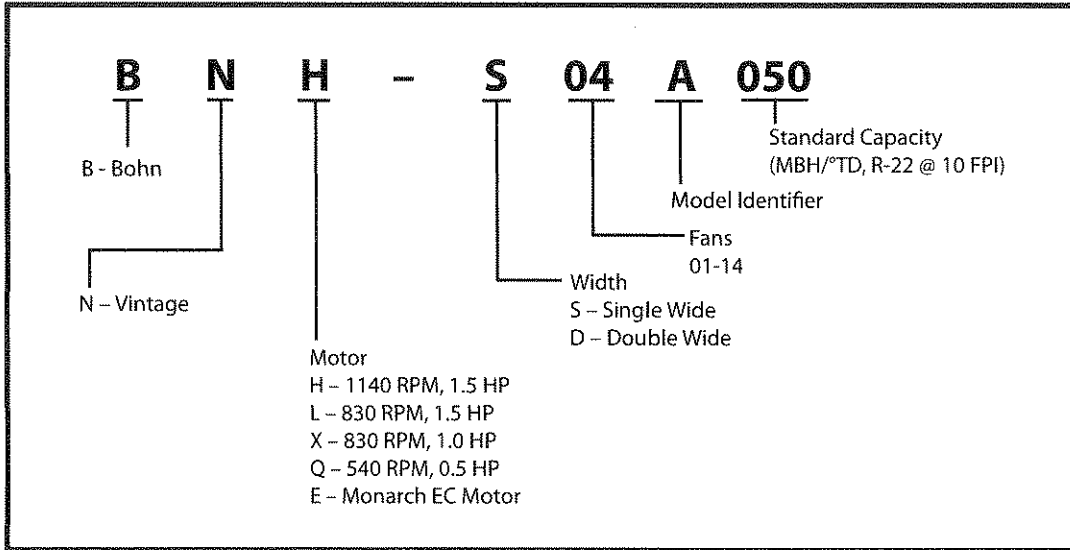

Condenser Selection

Capacity for air-cooled condensers are based on Total Heat of Rejection (THR) at the condenser. Total heat of rejection is equal to net refrigeration at the evaporator (compressor capacity) plus the energy input into the refrigerant by the compressor (heat of compression). The heat of compression will vary depending on the compressor manufacturer, type of compressor and the operating conditions of the compressor. Whenever possible, it is recommended that you obtain the heat of compression value from the compressor manufacturer.

If this is not available, the THR can be estimated using the following formula:

$$\text{THR} = (\text{Compressor Capacity}) * (\text{Heat of Compression Factor, Tables 1 \& 2})$$

Table 1 contains heat of compression factors for suction cooled compressors and Table 2 contains factors for open drive compressors. For refrigeration systems beyond the range of Tables 1 and 2, use the following equations to estimate THR:

Open Compressors:

$$\text{THR} = \text{Compressor Capacity (BTUH)} + (2545) * (\text{Break Horsepower, BHP})$$

Suction Cooled Compressors:

$$\text{THR} = \text{Compressor Capacity (BTUH)} + (3413 * \text{KW})$$

The compressor capacity is effected by its altitude. If the condenser location is above sea level, an additional correction is required to the THR, as follows:

$$\text{THR (altitude)} = \text{THR} * \text{Altitude Correction Factor, Table 3}$$

Selection Example

Compressor capacity:	350,000
Evaporator temperature:	+25° F
Condensing temperature:	115° F
Ambient temperature	95° F
Refrigerant:	R-22
Compressor type:	Semi-hermetic, suction cooled
Condenser type:	540 RPM, one row of fans
Condenser altitude:	1,000 feet

Step 1: Estimate Condenser THR

From Table 1 for suction cooled compressors, at +25° F suction and 115° F condensing temperature, select a heat of compressor factor of 1.335.

$$\begin{aligned} \text{THR} &= \text{Compressor Capacity} * \text{Heat of Compression Factor} \\ &= 350,000 * 1.335 \\ &= 467,250 \end{aligned}$$

Step 2: Correct for Altitude

From Table 3 obtain an altitude correction factor of 1.02 for 1,000 feet.

$$\begin{aligned} \text{THR} &= \text{THR (from step 1)} * \text{Altitude Correction Factor (design)} \\ &= 467,250 * 1.02 \\ &= 476,595 \end{aligned}$$

Step 3: Calculate Design Condenser T.D.

$$\begin{aligned} \text{Design Condenser T.D.} &= \text{Condensing Temp} - \text{Ambient Temp} \\ &= 115 - 95 \\ &= 20^\circ \text{ T.D.} \end{aligned}$$

Step 4: Condenser Selection

Condenser capacities for condensers with one row of fans at 540 RPM are located in Table 6. These capacities are given in MBH/°TD. Convert the THR calculated in step 2 to MBH/°TD by dividing by 1,000 to get THR in MBH. Then divide the THR by the design TD to get MBH/°TD.

$$\text{THR (MBH)} = 476,595 / 1,000 = 476.6$$

$$\text{THR (MBH/°TD)} = 476.6 / 20 = 23.83$$

Locate the 10 FPI column for R-22 refrigerant and read down until you locate a value equal to or just larger than 23.83. This value is 25.9. Read horizontally to the left to obtain a condenser model of BNQ-S05-A026.

Step 5: Calculate Actual T.D. and Condensing Temperature

The actual condenser T.D. can be calculated by dividing the design THR by the condenser rating.

$$\begin{aligned} \text{Actual T.D.} &= \text{THR (Design)} / (\text{Rating @ } 1^\circ \text{ T.D.}) \\ &= 476.6 / 25.9 \\ &= 18.4^\circ \text{ F T.D.} \end{aligned}$$

The actual condensing temperature is the actual T.D. plus the ambient temperature.

$$\begin{aligned} \text{Actual Condensing Temperature} &= (\text{Actual T.D.}) + (\text{Ambient}) \\ &= 18.4 + 95 \\ &= 113.4^\circ \text{ F.} \end{aligned}$$

Table 1. Heat of Compression Factor for Suction Cooled Compressors.

Suction Temp. °F	Condensing Temperature °F				
	90°	100°	110°	120°	130°
-40°	1.56	1.63	1.72	1.81	1.94
-30°	1.49	1.55	1.62	1.7	1.8
-20°	1.43	1.49	1.55	1.62	1.7
-10°	1.38	1.43	1.49	1.55	1.63
0°	1.34	1.38	1.43	1.49	1.56
5°	1.31	1.36	1.41	1.48	1.55
10°	1.29	1.34	1.39	1.44	1.52
15°	1.26	1.31	1.36	1.41	1.48
20°	1.24	1.28	1.33	1.38	1.44
25°	1.22	1.26	1.31	1.36	1.42
30°	1.2	1.24	1.28	1.33	1.39
40°	1.17	1.2	1.24	1.28	1.33

Table 2. Heat of Compression Factor for Open Drive Compressors.

Evaporator Temp. °F	Condensing Temperature °F					
	90°	100°	110°	120°	130°	140°
-30°	1.37	1.42	1.47	—	—	—
-20°	1.33	1.37	1.42	1.47	—	—
-10°	1.28	1.32	1.37	1.42	1.47	—
0°	1.24	1.28	1.32	1.37	1.41	1.47
5°	1.23	1.26	1.3	1.35	1.39	1.45
10°	1.21	1.24	1.28	1.32	1.36	1.42
15°	1.19	1.22	1.26	1.3	1.34	1.4
20°	1.17	1.2	1.24	1.28	1.32	1.37
25°	1.16	1.19	1.22	1.26	1.3	1.35
30°	1.14	1.17	1.2	1.24	1.27	1.32
40°	1.12	1.15	1.17	1.2	1.23	1.28
50°	1.09	1.12	1.14	1.17	1.2	1.24

Table 3. Altitude Correction Factors.

Altitude	Correction Factor
0	1
1,000	1.02
2,000	1.05
3,000	1.07
4,000	1.1
5,000	1.12
6,000	1.15
7,000	1.17

Multi-Circuiting Selection

Multi-Circuiting Selection Procedure

The air-cooled condensers are available with more than one refrigerant circuit. The condenser will be factory assembled with the condenser coil divided into individual refrigerant circuits, each sized

for its own specific application. Each circuit is supplied with its own inlet and outlet connections, individually labeled.

Multi-Circuit Condenser Selection

Given four suction cooled compressors with conditions shown in Table 4. The condenser shall have 830, 1.0 RPM fan motors,

with two rows of fans. The condenser location is at 3,000 ft. and the design ambient is 95°F.

Selection Procedure

Step 1: Input customer data in Table 4 in columns 1, 2, 3, 4 and 5.

Step 2: From Table 1, select the heat of compression factor for suction cooled compressors and input into Column #6.

Step 3: From Table 3 obtain the altitude correction factor and input into Column #7.

Step 4: From Table 5 obtain the refrigerant capacity factor and input into Column #8.

Step 5: Calculate the design T.D. for each circuit by subtracting the ambient temperature from the circuit design condensing temperature and input into Column #9.

$$T.D. = \text{Design Condensing Temperature} - \text{Ambient Temperature}$$

Step 6: Calculate the design THR / °T.D. for each circuit. Multiply Column #5 by Column #6 and Column #7 to calculate the THR for each circuit. Divide the result by the refrigerant correction factor, Column #8 to convert the capacities to a common refrigerant. Divide the result by the design T.D., Column #9 to calculate the design THR / °T.D. and input into Column #10.

$$\text{Design THR} / \text{°T.D.} = \frac{\text{Compressor Capacity (\#5)} * \text{Heat of Compressor Factor (\#6)} * \text{Altitude Factor (\#7)}}{\text{Refrigerant Capacity Factor (\#8)} * \text{Design T.D. (\#9)}}$$

Example for Circuit #1:

$$\text{Design THR} / \text{°T.D.} = \frac{235,000 * 1.31 * 1.07}{1.02 * 15}$$

$$= 21,529 \text{ BTUH} / \text{°T.D.}$$

Step 7: Add the design THR / °T.D. for each circuit in column #10, to get a total of 39,578 BTUH / °T.D. Divide this total by 1,000 to get 39.6 MBH / °T.D.

Step 8: From Table 8 for two rows of condenser fans with 830 RPM, 1.0 HP fan motors, locate the column for R-404A capacity with 10 FPI. Read down the column until you get to a capacity equal to or greater than 39.6 MBH / °T.D. This value is 44.5 which corresponds to a BNX-D06-A045. From Table 9 obtain the total number of feeds available as 56.

Multi-Circuiting Condenser

Table 4. Condenser Multi-Circuit Selection

1	2	3	4	5	X	6	X	7	÷	8	÷	9	=	10	11	12	13		
Circuit Name	Evap. Temp. °F	Design Cond. Temp. °F	Comp. Refrig. Type	Cap. BTUH	X	Heat of Com. press. Factor	X	Altitude Factor	÷	Refrig. Cap. Factor	÷	Design Cond. T.D.	=	Design THR/°TD	No. of Feeds Per Circ.	Actual Cond. T.D.	Actual Cond. Temp. °F		
1	25	110	22	235,000	X	1.31	X	1.07	÷	1.02	÷	15	=	21,529	31	13.1	108.1		
2	20	110	134a	61,000	X	1.33	X	1.07	÷	.97	÷	15	=	5,966	8	14.1	109.1		
3	-10	105	22	31,000	X	1.46	X	1.07	÷	1.02	÷	10	=	4,748	7	8.5	103.5		
4	-20	105	22	46,000	X	1.52	X	1.07	÷	1.02	÷	10	=	7,335	10	9.2	104.2		
													TOTAL	=	39,578	56			
															39,578 / 1,000 = 39.6 MBH/°TD				

Step 9: Determine the number of feeds per circuit. Divide the design THR / °T.D. in Column #10 by the total capacity required (39,578) and multiply this result by the number of feeds available, which is 56. Round this value to the nearest integer and place in Column #11. Add the individual feeds per circuit to get a total number of feeds for the condenser. This total must equal the total number of feeds available for the condenser (56).

$$\text{Number of feeds/circuit} = \frac{\text{Design THR} / \text{°T.D.}(\#10) * \text{Number of Circuits Available} (56)}{\text{Total Capacity Required} (39,578)}$$

Step 10: Calculate actual condensing T.D., (ATD):

$$\text{ATD} = \frac{\text{Design T.D.} (\#9) * \text{Design THR} / \text{°T.D.} (\#10) * \text{Number of Feeds Available} (56)}{\text{Number Feeds} / \text{CIR} (\#11) * \text{Condenser Capacity} / \text{°T.D.} (\text{Step} \#8) * 1,000}$$

Example for Circuit #1:

$$\text{ATD} = \frac{15 * 21,529 * 56}{31 * 44.5 * 1,000} = 13.1\text{°F.}$$

Input these T.D. values in column #12.

Step 11: Calculate the actual condensing temperature. Actual condensing temperature is equal to the actual condensing T.D., Column #12 plus the design ambient (95°). Input these values in Column #13. If the actual condensing temperature for each circuit is too high, it may be necessary to adjust the number of feeds per circuit or to select the next larger condenser size and recalculate the number of feeds per circuit.

Table 5. Refrigerant Capacity Factor.

Refrigerant	Capacity Factor
R-22	1.02
R-134a	0.97
R-404A	1
R-410A	1.02
R-502	1
R-507	1

CONDENSER CAPACITY

BNQ 540 830 EC 1140

Ambassador Series
Table 6. Ambassador BNQ Models, 540 RPM, 0.5 HP, 30" Fan Diameter

Model	R-22 R-410A MBH / 1° TD				R-404A MBH / 1° TD			
	8 FPI	10 FPI	12 FPI	14 FPI	8 FPI	10 FPI	12 FPI	14 FPI
BNQ-S01-A005	4.6	5.2	5.6	5.9	4.6	5.1	5.5	5.8
BNQ-S01-A006	5.5	6.1	6.4	6.6	5.4	5.9	6.2	6.5
BNQ-S02-A008	7.2	8.0	8.7	9.1	7.0	7.8	8.5	8.9
BNQ-S02-A010	9.4	10.3	10.8	11.8	9.2	10.1	10.6	11.6
BNQ-S02-A011	10.8	11.5	11.9	12.3	10.6	11.2	11.7	12.0
BNQ-S03-A016	14.1	15.6	16.2	16.9	13.8	15.2	15.9	16.6
BNQ-S03-A017	16.2	17.2	17.9	19.8	15.9	16.9	17.5	19.4
BNQ-S04-A021	18.8	20.7	21.6	23.5	18.4	20.3	21.2	23.0
BNQ-S04-A023	21.6	22.9	23.8	24.5	21.2	22.4	23.3	24.0
BNQ-S05-A026	23.5	25.9	27.0	29.3	23.1	25.4	26.4	28.8
BNQ-S05-A029	27.0	28.6	29.8	30.7	26.5	28.1	29.2	30.1
BNQ-S06-A034	32.4	34.4	35.7	36.8	31.8	33.7	35.0	36.1
BNQ-S07-A042	38.4	41.6	42.8	44.3	37.7	40.7	41.9	43.4
BNQ-D04-A016	14.3	16.0	17.3	18.2	14.0	15.6	16.9	17.9
BNQ-D04-A021	18.8	20.7	21.6	23.6	18.4	20.3	21.2	23.2
BNQ-D04-A023	21.6	22.9	23.8	24.5	21.2	22.4	23.3	24.0
BNQ-D06-A031	28.2	31.0	32.4	33.8	27.6	30.4	31.8	33.1
BNQ-D06-A034	32.4	34.4	35.7	39.5	31.8	33.7	35.0	38.7
BNQ-D08-A041	37.6	41.4	43.2	47.0	36.9	40.6	42.3	46.1
BNQ-D08-A046	43.2	45.8	47.6	49.0	42.4	44.9	46.7	48.1
BNQ-D10-A052	47.0	51.8	54.0	58.7	46.1	50.7	52.9	57.5
BNQ-D10-A057	54.0	57.3	59.5	61.3	53.0	56.1	58.3	60.1
BNQ-D12-A069	64.8	68.7	71.4	73.6	63.6	67.3	70.0	72.1
BNQ-D14-A083	76.8	83.1	85.5	88.6	75.3	81.5	83.8	86.8

BOLD indicates standard model capacity.

CONDENSER SPECIFICATIONS

BNQ 540 830 EC 1140

Table 7. Ambassador BNQ Models, 540 RPM, 0.5 HP, 30" Fan Diameter

Ambassador Series

Model	CFM	208-230/3/60			460/3/60			Unit kW	Conn. (in.)	Max. No. of Feeds	Approx. Net Weight (lbs)
		FLA	MCA	MOPD	FLA	MCA	MOPD				
BNQ-S01-A005	5,400	3.5	15.0	15	1.8	15.0	15	0.4	1 3/8	7	330
BNQ-S01-A006	5,200	3.5	15.0	15	1.8	15.0	15	0.4	1 3/8	14	360
BNQ-S02-A008	11,200	7.0	15.0	15	3.5	15.0	15	0.9	1 3/8	14	580
BNQ-S02-A010	10,800	7.0	15.0	15	3.5	15.0	15	0.9	1 5/8	21	630
BNQ-S02-A011	10,400	7.0	15.0	15	3.5	15.0	15	0.9	2 1/8	28	680
BNQ-S03-A016	16,100	10.5	15.0	20	5.3	15.0	15	1.3	2 1/8	21	930
BNQ-S03-A017	15,600	10.5	15.0	20	5.3	15.0	15	1.3	2 1/8	28	1,000
BNQ-S04-A021	21,500	14.0	15.0	20	7.0	15.0	15	1.7	2 1/8	21	1,210
BNQ-S04-A023	20,800	14.0	15.0	20	7.0	15.0	15	1.7	2 5/8	28	1,310
BNQ-S05-A026	26,900	17.5	20.0	25	8.8	15.0	15	2.2	2 5/8	21	1,510
BNQ-S05-A029	26,000	17.5	20.0	25	8.8	15.0	15	2.2	2 5/8	28	1,640
BNQ-S06-A034	31,200	21.0	21.9	30	10.5	15.0	15	2.6	2 5/8	28	1,950
BNQ-S07-A042	36,400	24.5	25.4	35	12.3	15.0	15	3.1	2 @ 2 5/8	28	2,240
BNQ-D04-A016	22,300	14.0	15.0	20	7.0	15.0	15	1.7	2 @ 1 3/8	28	1,240
BNQ-D04-A021	21,500	14.0	15.0	20	7.0	15.0	15	1.7	2 @ 1 5/8	42	1,340
BNQ-D04-A023	20,800	14.0	15.0	20	7.0	15.0	15	1.7	2 @ 2 1/8	56	1,440
BNQ-D06-A031	32,300	21.0	21.9	30	10.5	15.0	15	2.6	2 @ 2 1/8	42	1,990
BNQ-D06-A034	31,200	21.0	21.9	30	10.5	15.0	15	2.6	2 @ 2 1/8	56	2,140
BNQ-D08-A041	43,000	28.0	28.9	35	14.0	15.0	15	3.5	2 @ 2 1/8	42	2,630
BNQ-D08-A046	41,600	28.0	28.9	35	14.0	15.0	15	3.5	2 @ 2 5/8	56	2,830
BNQ-D10-A052	53,700	35.0	35.9	45	17.5	20.0	20	4.4	2 @ 2 5/8	42	3,290
BNQ-D10-A057	52,100	35.0	35.9	45	17.5	20.0	20	4.4	2 @ 2 5/8	56	3,540
BNQ-D12-A069	62,500	42.0	42.9	50	21.0	21.4	25	5.2	2 @ 2 5/8	56	4,230
BNQ-D14-A083	72,900	49.0	49.9	50	24.5	24.9	25	6.1	4 @ 2 5/8	56	4,910

CONDENSER CAPACITY

BNX 540 830 EC 1140

Table 8. Ambassador BNX Models, 830 RPM, 1.0 HP, 30" Fan Diameter

Ambassador Series

Model	R-22 R-410A MBH / 1° TD				R-404A MBH / 1° TD			
	8 FPI	10 FPI	12 FPI	14 FPI	8 FPI	10 FPI	12 FPI	14 FPI
BNX-S01-A006	5.6	6.4	7.0	7.4	5.5	6.2	6.8	7.3
BNX-S01-A008	6.8	7.5	8.1	8.4	6.6	7.4	7.9	8.3
BNX-S02-A010	8.8	9.8	10.6	11.3	8.6	9.6	10.4	11.0
BNX-S02-A013	12.0	13.1	13.8	14.8	11.8	12.8	13.6	14.5
BNX-S02-A015	14.0	15.1	15.7	16.0	13.7	14.8	15.3	15.7
BNX-S03-A020	18.0	19.7	20.8	21.8	17.7	19.3	20.4	21.4
BNX-S03-A023	21.0	22.7	23.5	25.3	20.5	22.3	23.0	24.8
BNX-S04-A026	24.1	26.3	27.7	29.3	23.6	25.7	27.1	28.8
BNX-S04-A030	27.9	30.3	31.3	32.0	27.4	29.7	30.7	31.4
BNX-S05-A033	30.1	32.8	34.6	36.7	29.5	32.1	33.9	36.0
BNX-S05-A038	34.9	37.8	39.2	40.1	34.2	37.1	38.4	39.3
BNX-S06-A045	41.9	45.4	47.0	48.1	41.1	44.5	46.1	47.1
BNX-S07-A052	47.7	52.0	54.8	56.1	46.8	51.0	53.7	55.0
BNX-D04-A020	17.5	19.6	21.2	22.5	17.2	19.2	20.8	22.0
BNX-D04-A026	24.1	26.2	27.7	29.7	23.6	25.7	27.1	29.1
BNX-D04-A030	27.9	30.3	31.3	32.0	27.4	29.7	30.7	31.4
BNX-D06-A039	36.1	39.4	41.5	43.7	35.4	38.6	40.7	42.8
BNX-D06-A045	41.9	45.4	47.0	50.6	41.1	44.5	46.1	49.6
BNX-D08-A052	48.1	52.5	55.4	58.6	47.1	51.4	54.3	57.5
BNX-D08-A061	55.9	60.6	62.7	64.1	54.8	59.3	61.4	62.8
BNX-D10-A066	60.1	65.6	69.2	73.5	58.9	64.3	67.8	72.0
BNX-D10-A076	69.9	75.7	78.3	80.1	68.5	74.2	76.8	78.5
BNX-D12-A091	83.8	90.8	94.0	96.1	82.1	89.0	92.1	94.2
BNX-D14-A104	95.5	104.1	109.6	112.2	93.6	102.0	107.5	110.1

BOLD indicates standard model capacity.

CONDENSER SPECIFICATIONS

BNX 540 830 EC 1140

Table 9. Ambassador BNX Models, 830 RPM, 1.0 HP, 30" Fan Diameter

Model	CFM	208-230/3/60			460/3/60			Unit kW	Conn. (in.)	Max. No. of Feeds	Approx. Net Wt. (lbs)
		FLA	MCA	MOPD	FLA	MCA	MOPD				
BNX-S01-A006	7,600	4.8	15.0	15	2.4	15.0	15	1.1	1 3/8	7	330
BNX-S01-A008	7,300	4.8	15.0	15	2.4	15.0	15	1.1	1 3/8	14	360
BNX-S02-A010	15,900	9.6	15.0	20	4.8	15.0	15	2.2	1 3/8	14	580
BNX-S02-A013	15,200	9.6	15.0	20	4.8	15.0	15	2.2	1 5/8	21	630
BNX-S02-A015	14,700	9.6	15.0	20	4.8	15.0	15	2.2	2 1/8	28	680
BNX-S03-A020	22,900	14.4	20.0	25	7.2	15.0	15	3.4	2 1/8	21	930
BNX-S03-A023	22,000	14.4	20.0	25	7.2	15.0	15	3.4	2 1/8	28	1,000
BNX-S04-A026	29,800	19.2	20.4	30	9.6	15.0	15	4.5	2 1/8	21	1,210
BNX-S04-A030	28,400	19.2	20.4	30	9.6	15.0	15	4.5	2 5/8	28	1,310
BNX-S05-A033	37,300	24.0	25.2	35	12.0	15.0	15	5.6	2 5/8	21	1,510
BNX-S05-A038	35,500	24.0	25.2	35	12.0	15.0	15	5.6	2 5/8	28	1,640
BNX-S06-A045	42,600	28.8	30.0	40	14.4	20.0	20	6.7	2 5/8	28	1,950
BNX-S07-A052	49,700	33.6	34.8	45	16.8	20.0	20	7.8	2 @ 2 5/8	28	2,240
BNX-D04-A020	31,700	19.2	20.4	30	9.6	15.0	15	4.5	2 @ 1 3/8	28	1,240
BNX-D04-A026	30,500	19.2	20.4	30	9.6	15.0	15	4.5	2 @ 1 5/8	42	1,340
BNX-D04-A030	29,300	19.2	20.4	30	9.6	15.0	15	4.5	2 @ 2 1/8	56	1,440
BNX-D06-A039	45,700	28.8	30.0	40	14.4	20.0	20	6.7	2 @ 2 1/8	42	1,990
BNX-D06-A045	44,000	28.8	30.0	40	14.4	20.0	20	6.7	2 @ 2 1/8	56	2,140
BNX-D08-A052	59,700	38.4	39.6	50	19.2	20.0	25	8.9	2 @ 2 1/8	42	2,630
BNX-D08-A061	56,800	38.4	39.6	50	19.2	20.0	25	8.9	2 @ 2 5/8	56	2,830
BNX-D10-A066	74,600	48.0	49.2	60	24.0	24.6	30	11.2	2 @ 2 5/8	42	3,290
BNX-D10-A076	71,000	48.0	49.2	60	24.0	24.6	30	11.2	2 @ 2 5/8	56	3,540
BNX-D12-A091	85,200	57.6	58.8	70	28.8	29.4	35	13.4	2 @ 2 5/8	56	4,230
BNX-D14-A104	99,400	67.2	68.4	80	33.6	34.2	40	15.6	4 @ 2 5/8	56	4,910

Ambassador Series

CONDENSER CAPACITY

BNL 540 830 EC 1140

Ambassador Series

Table 10. Ambassador BNL Models, 830 RPM, 1.5 HP, 30" Fan Diameter

Model	R-22 R-410A MBH / 1" TD				R-404A MBH / 1" TD			
	8 FPI	10 FPI	12 FPI	14 FPI	8 FPI	10 FPI	12 FPI	14 FPI
BNL-S01-A007	5.9	6.7	7.3	7.9	5.8	6.6	7.2	7.7
BNL-S01-A008	7.2	8.0	8.6	9.0	7.0	7.8	8.4	8.8
BNL-S02-A010	9.1	10.1	11.0	11.7	8.9	9.9	10.8	11.4
BNL-S02-A014	12.6	13.9	14.9	15.7	12.4	13.6	14.6	15.4
BNL-S02-A016	15.0	16.1	16.8	17.6	14.7	15.8	16.5	17.3
BNL-S03-A021	19.0	20.9	22.3	23.4	18.6	20.5	21.8	23.0
BNL-S03-A024	22.5	24.2	25.2	26.9	22.0	23.8	24.7	26.3
BNL-S04-A028	25.3	27.8	29.7	31.2	24.8	27.3	29.1	30.6
BNL-S04-A032	30.0	32.3	33.6	35.2	29.4	31.7	32.9	34.5
BNL-S05-A035	32.1	35.5	37.4	39.0	31.4	34.7	36.6	38.2
BNL-S05-A042	38.4	41.6	43.4	44.7	37.7	40.8	42.5	43.8
BNL-S06-A050	46.1	49.9	52.1	53.6	45.2	48.9	51.0	52.6
BNL-S07-A055	50.5	55.0	58.0	60.2	49.5	53.9	56.8	59.0
BNL-D04-A020	18.1	20.2	22.0	23.3	17.7	19.8	21.5	22.9
BNL-D04-A028	25.3	27.8	29.7	31.4	24.8	27.3	29.1	30.7
BNL-D04-A032	30.0	32.3	33.6	35.2	29.4	31.7	32.9	34.5
BNL-D06-A042	37.9	41.8	44.5	46.9	37.2	40.9	43.7	45.9
BNL-D06-A048	45.0	48.4	50.4	53.7	44.1	47.5	49.4	52.7
BNL-D08-A056	50.6	55.7	59.4	62.4	49.6	54.6	58.3	61.1
BNL-D08-A065	60.0	64.6	67.2	70.4	58.8	63.3	65.8	69.0
BNL-D10-A071	64.2	70.9	74.7	78.0	62.9	69.5	73.2	76.5
BNL-D10-A083	76.9	83.1	86.8	89.4	75.3	81.5	85.0	87.6
BNL-D12-A100	90.4	99.8	104.1	107.3	92.2	97.8	102.0	105.1
BNL-D14-A110	101.1	110.0	116.0	120.3	99.1	107.9	113.7	117.9

BOLD indicates standard model capacity.

CONDENSER SPECIFICATIONS

BNL 540 830 EC 1140

Table 11. Ambassador BNL Models, 830 RPM, 1.5 HP, 30" Fan Diameter

Model	CFM	208-230/3/60			460/3/60			575/3/60			Unit kW	Conn. (in.)	Max. No. of Feeds	Approx. Net Weight (lbs)
		FLA	MCA	MOPD	FLA	MCA	MOPD	FLA	MCA	MOPD				
BNL-S01-A007	8,400	6.6	15.0	25	3.3	15.0	15	2.6	15.0	15	1.4	1 3/8	7	330
BNL-S01-A008	8,000	6.6	15.0	25	3.3	15.0	15	2.6	15.0	15	1.4	1 3/8	14	360
BNL-S02-A010	17,500	13.2	15.0	30	6.6	15.0	15	5.2	15.0	15	2.7	1 3/8	14	580
BNL-S02-A014	16,700	13.2	15.0	30	6.6	15.0	15	5.2	15.0	15	2.7	1 5/8	21	630
BNL-S02-A016	16,100	13.2	15.0	30	6.6	15.0	15	5.2	15.0	15	2.7	2 1/8	28	680
BNL-S03-A021	25,100	19.8	21.5	35	9.9	15.0	15	7.8	15.0	15	4.1	2 1/8	21	930
BNL-S03-A024	24,100	19.8	21.5	35	9.9	15.0	15	7.8	15.0	15	4.1	2 1/8	28	1,000
BNL-S04-A028	32,800	26.4	28.1	45	13.2	15.0	20	10.4	15.0	15	5.4	2 1/8	21	1,210
BNL-S04-A032	31,200	26.4	28.1	45	13.2	15.0	20	10.4	15.0	15	5.4	2 5/8	28	1,310
BNL-S05-A035	41,000	33.0	34.7	50	16.5	20.0	25	13.0	15.0	20	6.8	2 5/8	21	1,510
BNL-S05-A042	39,100	33.0	34.7	50	16.5	20.0	25	13.0	15.0	20	6.8	2 5/8	28	1,640
BNL-S06-A050	46,900	39.6	41.3	50	19.8	20.6	25	15.6	20.0	20	8.1	2 5/8	28	1,950
BNL-S07-A055	54,700	46.2	47.9	60	23.1	23.9	30	18.2	20.0	25	9.5	2 @ 2 5/8	28	2,240
BNL-D04-A020	35,000	26.4	28.1	45	13.2	15.0	20	10.4	15.0	15	5.4	2 @ 1 3/8	28	1,240
BNL-D04-A028	33,500	26.4	28.1	45	13.2	15.0	20	10.4	15.0	15	5.4	2 @ 1 5/8	42	1,340
BNL-D04-A032	32,100	26.4	28.1	45	13.2	15.0	20	10.4	15.0	15	5.4	2 @ 2 1/8	28	1,440
BNL-D06-A042	50,200	39.6	41.3	50	19.8	20.6	25	15.6	20.0	20	8.1	2 @ 2 1/8	56	1,990
BNL-D06-A048	48,200	39.6	41.3	50	19.8	20.6	25	15.6	20.0	20	8.1	2 @ 2 1/8	56	2,140
BNL-D08-A056	65,600	52.8	54.5	70	26.4	27.2	35	20.8	21.5	25	10.8	2 @ 2 1/8	42	2,630
BNL-D08-A065	62,500	52.8	54.5	70	26.4	27.2	35	20.8	21.5	25	10.8	2 @ 2 5/8	56	2,830
BNL-D10-A071	82,000	66.0	67.7	80	33.0	33.8	40	26.0	26.7	30	13.5	2 @ 2 5/8	42	3,290
BNL-D10-A083	78,100	66.0	67.7	80	33.0	33.8	40	26.0	26.7	30	13.5	2 @ 2 5/8	56	3,540
BNL-D12-A100	93,700	79.2	80.9	90	39.6	40.4	45	31.2	31.9	35	16.2	2 @ 2 5/8	56	4,230
BNL-D14-A110	109,300	92.4	94.1	110	46.2	47.0	50	36.4	37.1	40	18.9	4 @ 2 5/8	56	4,910

Ambassador Series

Bohn Monarch Series Selection Tables

The new Bohn Monarch Series of air-cooled condensers incorporates EC motor technology to provide the quietest and most efficient condensers in the industry, using integrated variable speed technology.

Simplicity: Variable speed without the complexity

The Bohn Monarch Series is a complete system that incorporates an EC motor, integrated drive and control electronics, optimized swept motor blade and venturi panel in one simple package. Variable speed is accomplished without the complexities typically associated with Variable Frequency Drives.

Flexibility: Maximum efficiency, minimum sound, capacity when you need it

The Monarch Series condensers' integrated variable speed capability allows optimization to your operating conditions; at higher speeds on hot summer afternoons to maintain capacity or at lower speeds at night to meet a local sound ordinance. Whatever your requirements, the Bohn Monarch Series can be selected and programmed to your specific needs; whether it is lower energy costs, lower sound or both.

Reliability: The highest quality backed by industry-leading warranties

We are so confident in the reliability of the EC motor that we are providing an unprecedented 3-year warranty on the EC motor (2-year warranty on the unit) so you can be assured of worry-free operation.

Protection at every level

The EC motors have several built-in features that protect against locked-rotors, under-voltage protection and phase failure.

Variable Speed Operation

The Monarch Series condensers provide variable speed operation automatically; providing dramatically lower sound and energy levels than would be observed with condensers using traditional AC motors.

Typical performance of a Monarch Series condenser at various loads versus a 540 RPM or 1140 RPM condenser is shown in the charts on the next page.

Model Selection

Selecting the right Bohn Monarch Series unit for your needs is easier than you think, and is just as easy as selecting a standard unit.

Simply use Table 12 to find the model and fins per inch required to meet your capacity needs.

Selecting condensers with specific sound or energy levels

The variable speed nature allows selection to meet maximum sound or energy usage levels.

To select condensers with these goals in mind, please contact your sales representative. They will be able to help you select the appropriate model for your specific requirements.

Monarch Series

EC Sound Data (dBA @ 10 ft.)

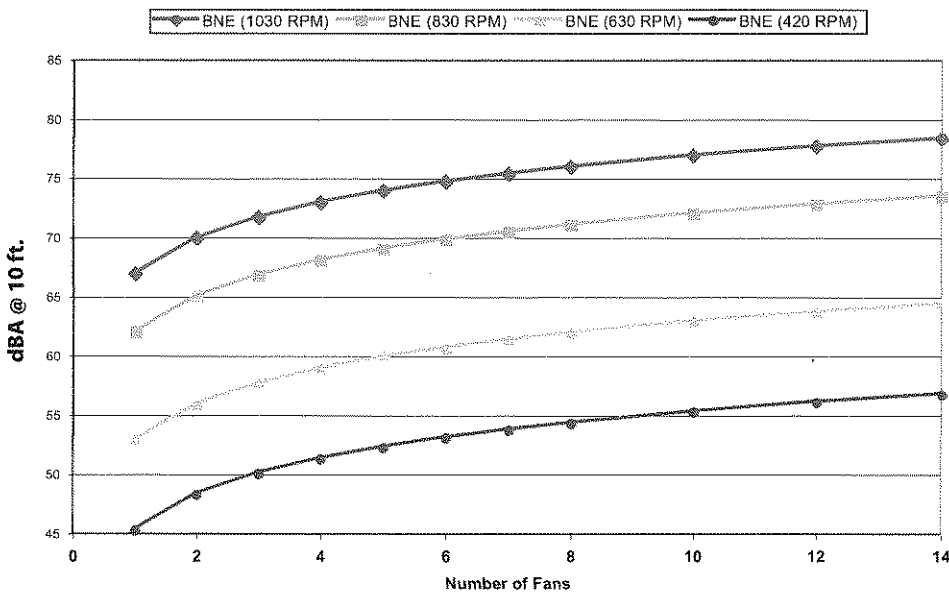

Fans	BNE 1030 RPM	BNE 830 RPM	BNE 630 RPM	BNE 420 RPM
1	66.9	62.0	52.9	45.3
2	69.9	65.0	55.9	48.3
3	71.7	66.8	57.7	50.1
4	72.9	68.0	58.9	51.3
5	73.9	69.0	59.9	52.3
6	74.7	69.8	60.7	53.1
7	75.4	70.5	61.4	53.8
8	75.9	71.0	61.9	54.3
10	76.9	72.0	62.9	55.3
12	77.7	72.8	63.7	56.1
14	78.4	73.5	64.4	56.8

Power Consumption Comparison

10 Fan EC Motor Condenser vs.
14 Fan 540 RPM Condenser and 10 Fan 1140 RPM Condenser
(Capacity - 83 MBH / °TD)

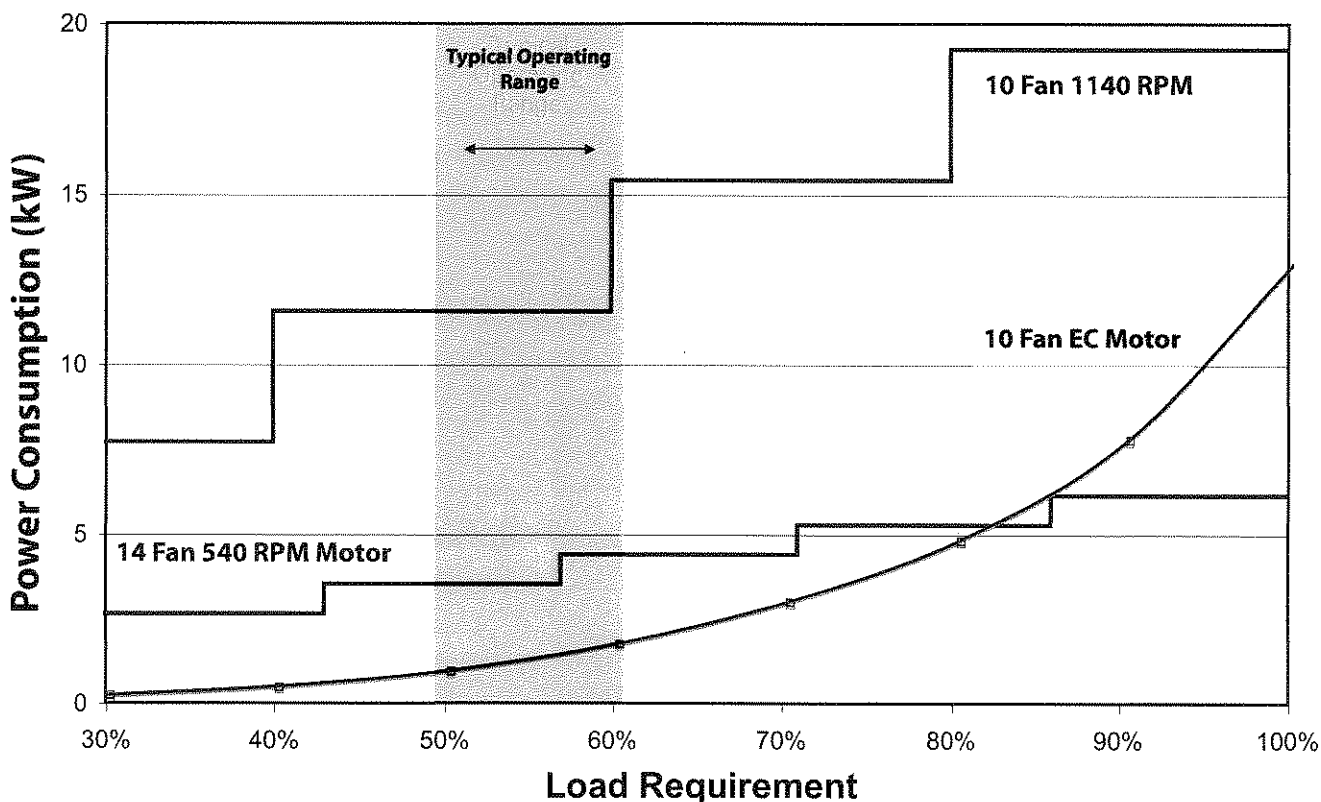

Monarch Series

10 Fan EC Motor Sound Production at Various Loads								
Percent of Max. Load	30%	40%	50%	60%	70%	80%	90%	100%
RPM	215	313	407	511	630	748	892	1030
dBA @ 10 ft	49.5	51.8	55	58.4	62.9	67.8	74.8	76.9

CONDENSER CAPACITY

BNE 540 830 EC T140

Table 12. Monarch BNE Models, 2.2 kW, 31.5" Fan Diameter

Monarch Series

Model	R-22 R-410A MBH / 1°TD				R-404A MBH / 1°TD			
	8 FPI	10 FPI	12 FPI	14 FPI	8 FPI	10 FPI	12 FPI	14 FPI
BNE-S01-A008	6.8	7.7	8.5	9.1	6.6	7.6	8.3	9.0
BNE-S01-A009	8.3	9.3	10.0	10.6	8.1	9.1	9.8	10.4
BNE-S02-A011	10.2	11.3	12.4	13.1	10.0	11.1	12.1	12.9
BNE-S02-A015	13.9	15.4	16.5	17.3	13.6	15.1	16.2	17.0
BNE-S02-A018	16.6	18.1	19.2	20.3	16.3	17.8	18.8	19.9
BNE-S03-A023	20.9	23.1	24.8	25.9	20.4	22.7	24.3	25.4
BNE-S03-A027	24.9	27.2	28.7	31.7	24.4	26.7	28.2	31.1
BNE-S04-A031	27.8	30.8	33.0	34.6	27.2	30.2	32.4	33.9
BNE-S04-A036	33.2	36.3	38.3	40.6	32.6	35.5	37.5	39.8
BNE-S05-A039	35.6	39.3	41.6	43.8	34.9	38.5	40.8	42.9
BNE-S05-A047	43.0	46.6	48.8	51.5	42.1	45.7	47.8	50.5
BNE-S06-A056	51.6	56.0	58.6	61.8	50.5	54.8	57.4	60.5
BNE-S07-A065	58.7	64.6	68.6	71.6	57.6	63.3	67.3	70.2
BNE-D04-A023	20.4	22.7	24.8	26.2	19.9	22.2	24.3	25.7
BNE-D04-A031	27.8	30.8	33.1	34.6	27.2	30.2	32.4	33.9
BNE-D04-A036	33.2	36.3	38.3	40.6	32.6	35.5	37.5	39.8
BNE-D06-A046	41.7	46.2	49.5	51.9	40.9	45.3	48.6	50.8
BNE-D06-A054	49.8	54.4	57.4	63.4	48.8	53.3	56.3	62.2
BNE-D08-A062	55.6	61.7	66.1	69.2	54.5	60.5	64.7	67.8
BNE-D08-A073	66.5	72.5	76.6	81.3	65.2	71.1	75.1	79.7
BNE-D10-A079	71.1	78.6	83.2	87.5	69.7	77.0	81.6	85.8
BNE-D10-A093	85.9	93.3	97.6	103.0	84.2	91.4	95.7	100.9
BNE-D12-A112	103.1	111.9	117.1	123.6	101.0	109.7	114.8	121.1
BNE-D14-A129	117.5	129.2	137.2	143.1	115.2	126.7	134.5	140.3

BOLD indicates standard model capacity.

CONDENSER SPECIFICATIONS

BNE 540 830 EC 1140

Table 13. Monarch BNE Models, 2.2 kW, 31.5" Fan Diameter

Model	CFM	208-230/3/60			460/3/60			Unit kW	Conn. (In.)	Max. Number of Feeds	Approx. Net Weight (lbs)
		FLA	MCA	MOPD	FLA	MCA	MOPD				
BNE-S01-A008	11,000	7.0	15.0	25	3.5	15.0	15	2.2	1 3/8	7	330
BNE-S01-A009	10,500	7.0	15.0	25	3.5	15.0	15	2.2	1 3/8	14	360
BNE-S02-A011	23,400	14.0	20.0	35	7.0	15.0	15	4.4	1 3/8	14	590
BNE-S02-A015	22,000	14.0	20.0	35	7.0	15.0	15	4.4	1 5/8	21	640
BNE-S02-A018	20,900	14.0	20.0	35	7.0	15.0	15	4.4	2 1/8	28	690
BNE-S03-A023	33,100	21.0	22.8	40	10.5	15.0	20	6.6	2 1/8	21	930
BNE-S03-A027	31,400	21.0	22.8	40	10.5	15.0	20	6.6	2 1/8	28	1,010
BNE-S04-A031	42,600	28.0	29.8	45	14.0	15.0	20	8.8	2 1/8	21	1,220
BNE-S04-A036	40,000	28.0	29.8	45	14.0	15.0	20	8.8	2 5/8	28	1,320
BNE-S05-A039	53,200	35.0	36.8	50	17.5	20.0	25	11.0	2 5/8	21	1,520
BNE-S05-A047	50,000	35.0	36.8	50	17.5	20.0	25	11.0	2 5/8	28	1,650
BNE-S06-A056	60,000	42.0	43.8	60	21.0	21.9	30	13.2	2 5/8	28	1,960
BNE-S07-A065	70,000	49.0	50.8	70	24.5	25.4	35	15.4	2 @ 2 5/8	28	2,260
BNE-D04-A023	46,700	28.0	29.8	45	14.0	15.0	20	8.8	2 @ 1 3/8	28	1,290
BNE-D04-A031	44,100	28.0	29.8	45	14.0	15.0	20	8.8	2 @ 1 5/8	42	1,390
BNE-D04-A036	41,800	28.0	29.8	45	14.0	15.0	20	8.8	2 @ 2 1/8	56	1,490
BNE-D06-A046	66,100	42.0	43.8	60	21.0	21.9	30	13.2	2 @ 2 1/8	42	2,060
BNE-D06-A054	62,700	42.0	43.8	60	21.0	21.9	30	13.2	2 @ 2 1/8	56	2,210
BNE-D08-A062	85,100	56.0	57.8	70	28.0	28.9	35	17.6	2 @ 2 1/8	42	2,730
BNE-D08-A073	80,000	56.0	57.8	70	28.0	28.9	35	17.6	2 @ 2 5/8	56	2,930
BNE-D10-A079	106,400	70.0	71.8	90	35.0	35.9	45	22.0	2 @ 2 5/8	42	3,410
BNE-D10-A093	100,100	70.0	71.8	90	35.0	35.9	45	22.0	2 @ 2 5/8	56	3,660
BNE-D12-A112	120,100	84.0	85.8	100	42.0	42.9	50	26.4	2 @ 2 5/8	56	4,370
BNE-D14-A129	140,100	98.0	99.8	110	49.0	49.9	50	30.8	4 @ 2 5/8	56	5,070

Monarch Series

1140 Series

For customers seeking an economical solution to their capacity requirements, Bohn now offers the 1140 RPM Series with enhancements to improve capacity and serviceability. The 1140 Series features a broader product range with capacities ranging from 15 to 249 nominal tons to address all applications.

New features include:

- Bohn's patent-pending ServiceEase™ motor mount
- New, high efficiency condenser coil designed for optimum performance
- Expanded product range from 15 to 249 nominal tons
- Galvanized steel cabinet with options for aluminum or painted galvanized steel

Standard Features

- 10 fins per inch spacing
- Modular design with models in both single and double wide fan configurations.
- All Bohn condensers incorporate the Floating Tube™ coil design, which virtually eliminates tube sheet leaks.
- Internal baffles provided between all fan cells
- Condensers up to 3 fans in length use 3/8" diameter tube to minimize refrigerant charge. Condensers 4 or more fans in length use 1/2" diameter tube to minimize refrigerant pressure drop
- Coated steel fan guards
- Weatherproof control panel with factory mounted door interrupt disconnect switch
- UL and UL listed for Canada

Available Options

- Multi-circuiting at no additional charge
- Optional 8, 12 or 14 FPI spacing
- Fan-cycle control panels
- Alternate coil construction including BohnGuard™ coated fins, epoxy or phenolic coated fins and copper fins
- Hinged fan panels for ease of servicing
- Side access panels
- Extended condenser legs for increased ground clearance
- Sealrite wiring

CONDENSER CAPACITY

BNH 540 830 EC 1140

Table 14. Bohn 1140 Series BNH Models, 1140 RPM, 1.5 HP, 30" Fan Diameter

Model	R-22 R-410A MBH / 1" TD				R-404A MBH / 1" TD			
	8 FPI	10 FPI	12 FPI	14 FPI	8 FPI	10 FPI	12 FPI	14 FPI
BNH-S01-A007	6.4	7.3	8.0	8.6	6.3	7.2	7.9	8.5
BNH-S01-A009	7.8	8.7	9.5	10.0	7.6	8.6	9.3	9.8
BNH-S02-A011	9.6	10.7	11.7	12.4	9.4	10.5	11.5	12.1
BNH-S02-A015	13.1	14.5	15.6	16.3	12.8	14.2	15.3	16.0
BNH-S02-A017	15.7	17.1	18.1	19.2	15.3	16.7	17.7	18.8
BNH-S03-A022	19.7	21.8	23.4	24.5	19.3	21.4	22.9	24.0
BNH-S03-A026	23.5	25.7	27.1	29.9	23.1	25.2	26.6	29.3
BNH-S04-A029	26.2	29.1	31.2	32.6	25.7	28.5	30.5	32.0
BNH-S04-A034	31.4	34.2	36.1	38.3	30.7	33.5	35.4	37.6
BNH-S05-A037	33.6	37.1	39.3	41.3	32.9	36.4	38.5	40.5
BNH-S05-A044	40.5	44.0	46.1	48.6	39.7	43.1	45.1	47.6
BNH-S06-A053	48.6	52.8	55.3	58.3	47.7	51.7	54.1	57.1
BNH-S07-A061	55.4	61.0	64.7	67.5	54.3	59.8	63.5	66.2
BNH-D04-A021	19.2	21.4	23.4	24.8	18.8	21.0	22.9	24.3
BNH-D04-A029	26.2	29.1	31.2	32.6	25.7	28.5	30.6	32.0
BNH-D04-A034	31.4	34.2	36.1	38.3	30.7	33.5	35.4	37.6
BNH-D06-A044	39.4	43.6	46.7	48.9	38.6	42.8	45.8	47.9
BNH-D06-A051	47.0	51.3	54.2	59.8	46.1	50.3	53.1	58.7
BNH-D08-A058	52.5	58.2	62.3	65.3	51.4	57.0	61.1	63.9
BNH-D08-A068	62.7	68.4	72.3	76.7	61.5	67.1	70.8	75.1
BNH-D10-A074	67.1	74.2	78.5	82.6	65.7	72.7	76.9	80.9
BNH-D10-A088	81.0	88.0	92.1	97.2	79.4	86.2	90.2	95.2
BNH-D12-A106	97.2	105.6	110.5	116.6	95.3	103.5	108.3	114.2
BNH-D14-A122	110.8	121.9	129.5	135.0	108.6	119.5	126.9	132.4

BOLD indicates standard model capacity.

1140 Series

CONDENSER SPECIFICATIONS

BNH 540 830 EC 1140

Table 15. 1140 Series BNH Models, 1140 RPM, 1.5 HP, 30" Fan Diameter

Model	CFM	208-230/3/60 460/3/60			575/3/60			Unit kW	Conn. (in.)	Max. No. of Feeds	Approx. Net Wt. (lbs)			
		FLA	MCA	MOPD	FLA	MCA	MOPD							
BNH-S01-A007	9,900	7.0	15.0	25	3.5	15.0	15	2.8	15.0	15	1.9	1 3/8	7	330
BNH-S01-A009	9,500	7.0	15.0	25	3.5	15.0	15	2.8	15.0	15	1.9	1 3/8	14	360
BNH-S02-A011	20,500	14.0	20.0	35	7.0	15.0	15	5.6	15.0	15	3.8	1 3/8	14	580
BNH-S02-A015	19,800	14.0	20.0	35	7.0	15.0	15	5.6	15.0	15	3.8	1 5/8	21	630
BNH-S02-A017	19,000	14.0	20.0	35	7.0	15.0	15	5.6	15.0	15	3.8	2 1/8	28	680
BNH-S03-A022	29,700	21.0	22.8	40	10.5	15.0	20	8.4	15.0	15	5.8	2 1/8	21	930
BNH-S03-A026	28,500	21.0	22.8	40	10.5	15.0	20	8.4	15.0	15	5.8	2 1/8	28	1,000
BNH-S04-A029	38,600	28.0	29.8	45	14.0	15.0	20	11.2	15.0	15	7.7	2 1/8	21	1,210
BNH-S04-A034	37,000	28.0	29.8	45	14.0	15.0	20	11.2	15.0	15	7.7	2 5/8	28	1,310
BNH-S05-A037	48,300	35.0	36.8	50	17.5	20.0	25	14.0	15.0	20	9.6	2 5/8	21	1,510
BNH-S05-A044	46,200	35.0	36.8	50	17.5	20.0	25	14.0	15.0	20	9.6	2 5/8	28	1,640
BNH-S06-A053	55,400	42.0	43.8	60	21.0	21.9	30	16.8	20.0	25	11.5	2 5/8	28	1,950
BNH-S07-A061	64,700	49.0	50.8	70	24.5	25.4	35	19.6	20.3	25	13.5	2 @ 2 5/8	28	2,240
BNH-D04-A021	41,000	28.0	29.8	45	14.0	15.0	20	11.2	15.0	15	7.7	2 @ 1 3/8	28	1,240
BNH-D04-A029	39,600	28.0	29.8	45	14.0	15.0	20	11.2	15.0	15	7.7	2 @ 1 5/8	42	1,340
BNH-D04-A034	38,100	28.0	29.8	45	14.0	15.0	20	11.2	15.0	15	7.7	2 @ 2 1/8	56	1,440
BNH-D06-A044	59,400	42.0	43.8	60	21.0	21.9	30	16.8	20.0	25	11.5	2 @ 2 1/8	42	1,990
BNH-D06-A051	57,100	42.0	43.8	60	21.0	21.9	30	16.8	20.0	25	11.5	2 @ 2 1/8	56	2,140
BNH-D08-A058	77,200	56.0	57.8	70	28.0	28.9	35	22.4	23.1	30	15.4	2 @ 2 1/8	42	2,630
BNH-D08-A068	73,900	56.0	57.8	70	28.0	28.9	35	22.4	23.1	30	15.4	2 @ 2 5/8	56	2,830
BNH-D10-A074	96,500	70.0	71.8	90	35.0	35.9	45	28.0	28.7	35	19.2	2 @ 2 5/8	42	3,290
BNH-D10-A088	92,400	70.0	71.8	90	35.0	35.9	45	28.0	28.7	35	19.2	2 @ 2 5/8	56	3,540
BNH-D12-A106	110,900	84.0	85.8	100	42.0	42.9	50	33.6	34.3	40	23.1	2 @ 2 5/8	56	4,230
BNH-D14-A122	129,400	98.0	99.8	110	49.0	49.9	50	39.2	39.9	45	26.9	4 @ 2 5/8	56	4,910

1140 Series

CONDENSER DIMENSIONS

End Views

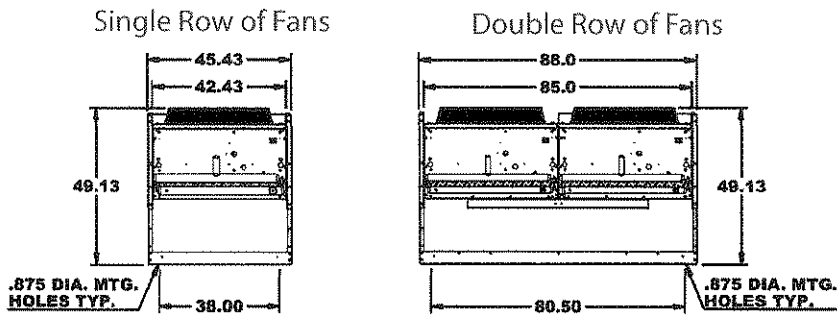

Side Views

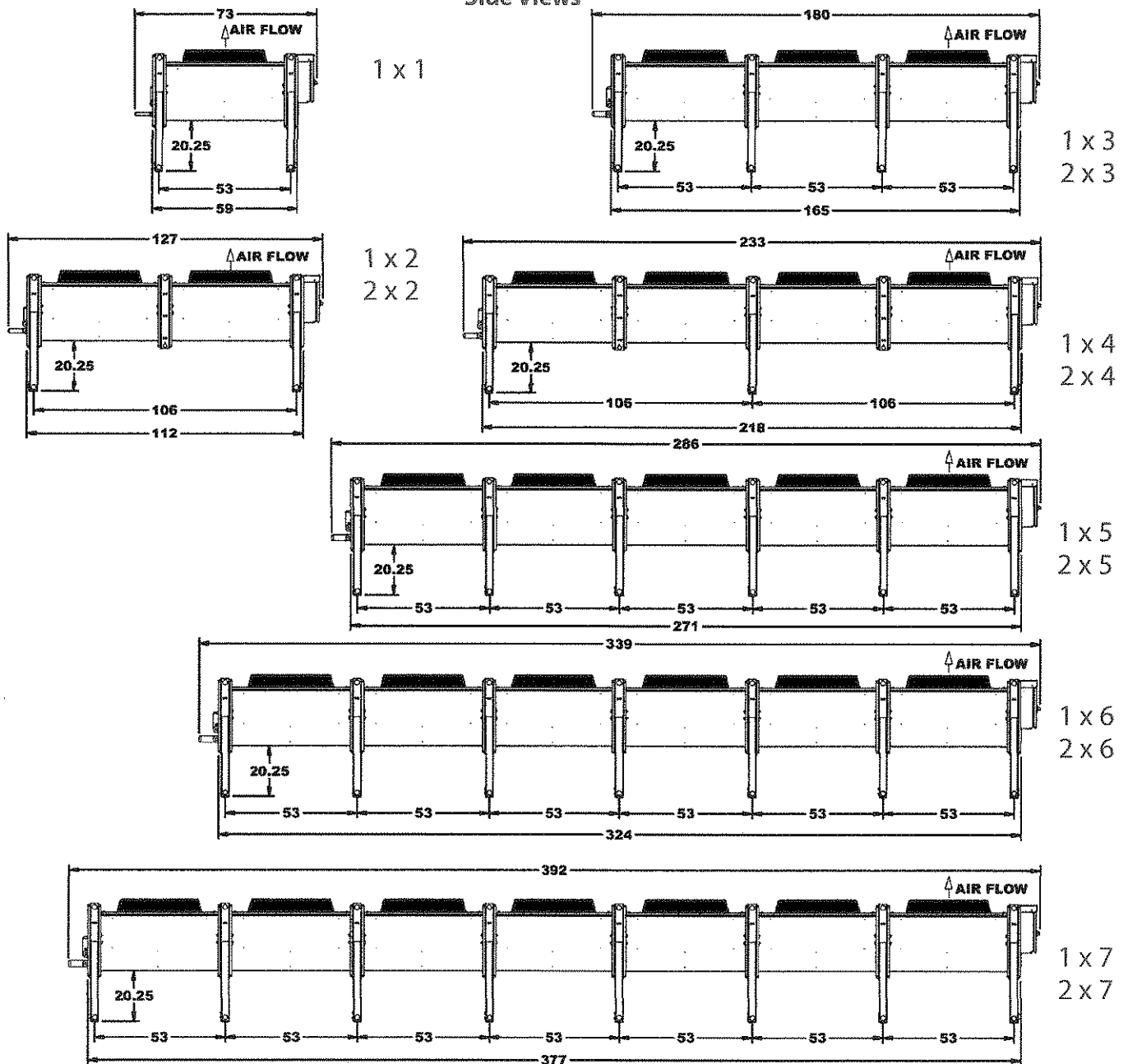

Fan Cycle Control Panels

Fan cycling panels are available to cycle fans on ambient temperature or condensing pressure or custom built control panels can be factory installed to interface with electronic refrigeration controllers.

- All fans are cycled with contactors.
- Condensers with a single row of fans cycle fans separately with one contactor per fan.
- Condensers with two rows of fans cycle fans in pairs, with one contactor for every pair of fans.
- Fans closest to the header end of the unit run continuously.

- Standard control circuit voltage is 230 volts. Control circuits with 24 or 115 volts are available on request.
- Control circuits are factory wired to a control circuit terminal board for convenient single point field wiring. Standard control circuits require an external power supply for powering control circuit (by others).
- A control circuit transformer is available on 460 volt condensers as a factory mounted option to provide power to the control circuit.

Ambient Fan Cycle

Condenser fans are controlled by ambient temperature using electronic temperature controls. Ambient fan cycling is recommended for multi-circuited condensers or single circuit condensers where there is little variation in condenser load.

Ambient fan cycling is limited in its ability to control head pressure to mild ambient conditions, see Table 16 for minimum ambients for fan cycling. Full year head pressure control can be obtained by combining ambient fan cycling with another means of head

pressure control, such as condenser flooding controls or variable speed. Combining these controls with ambient fan cycling has the additional advantage of reducing the amount of refrigerant required to flood the condenser.

See Table 17 for typical settings for ambient thermostats.

Pressure Fan Cycling

Condenser fans are controlled by pressure switches which monitor condenser pressure. Pressure fan cycling is ideal for those condensers which see a significant change in condenser load. Since the controls sense condensing pressure, they can cycle fans at any ambient temperature, in response to a change in condensing pressure.

An additional pressure switch is available as an option to cycle the fan closest to the header end of the condenser. This option is only recommended for condensers with large variations in condenser load caused by heat reclaim, hot gas defrost or a high percentage of compressor unloading.

Table 16. Minimum Ambient for Fan Cycling

Number of Fans		Design T.D.*				
Single Row	Double Row	30	25	20	15	10
2	4	35	45	55	60	70
3	6	15	30	40	55	65
4	8	0	15	30	45	60
5	10	0	10	20	35	55
6/7	12/14	0	0	10	30	50

*Based on maintaining 90° F minimum condensing temperature.

Table 17. Fan Cycling Thermostat Settings

Number of Fans		Design T.D.	Thermostat Setting				
Single Row	Double Rows		1	2	3	4	5
2	4	30	60				
		25	65				
		20	70				
		15	75				
		10	80				
3	6	30	60	40			
		25	65	55			
		20	70	60			
		15	75	65			
		10	80	75			
4	8	30	60	50	30		
		25	65	55	40		
		20	70	65	50		
		15	75	70	60		
		10	80	75	70		
5	10	30	60	55	45	30	
		25	65	60	50	35	
		20	70	65	60	40	
		15	75	70	65	55	
		10	80	75	70	65	
6/7	12/14	30	55	50	40	30	25
		25	65	60	55	45	35
		20	70	65	60	50	40
		15	75	70	65	60	50
		10	80	75	70	65	60

Variable Speed

Condenser head pressure control is provided by varying the air flow through the condenser by changing the RPM of the condenser fan. This control package is offered in combination with ambient fan cycling. The fan motor next to the header end of the condenser is the variable speed fan. The remainder of the fans are constant speed and are cycled separately using ambient sensing thermostats. On condensers with two rows of fans, two variable speed fans are provided (one per unit) and the remainder of the fans are constant speed and are cycled in pairs.

The variable speed control package consists of a special variable speed motor (1140 RPM, single phase) and an electronic speed control which controls the speed of the motor in response to condensing pressure. Fan motor, speed control and all related components are all factory mounted and wired. Two speed controls are provided on units with two rows of fans to allow for separate control of each fan motor.

Splitting Controls

Additional head pressure can be provided by valving off a portion of the condenser circuit and removing that portion from the refrigeration circuit, or splitting the condenser. In addition to providing a means of head pressure control, this control will reduce the amount of refrigerant required to operate the condenser with a flooded head pressure control.

sensing condensing pressure and a splitting relay. The splitting relay provides a set of dry contacts to control the valves required to split the condenser (valves supplied by others).

Condenser splitting is recommended as a seasonal adjustment controlled by ambient temperature. A pressure switch is also provided as a backup control to prevent high head pressures from occurring during heavy load conditions.

On condensers with double rows of fans, additional controls and contactors are provided to cycle all of the fans on the side of the condenser which has been split off.

On condensers with a single row of fans the control package consists of an ambient sensing thermostat, a pressure switch

Except as noted above, the splitting packages do not control fan cycling. It is recommended that fan cycling be controlled by combining the splitting package with pressure fan cycling.

Control Panels for Electronic Controllers

Custom control panels can often be fabricated to interface with many of the microprocessor based electronic refrigeration controls. These panels often include individual motor fusing, individual fan

motor contactors, splitting relays and printed circuit boards to interface with the microprocessor control. Contact the factory with your specific requirements.

Condenser Refrigerant Charge

The normal summer operating charge for condensers is shown in Table 18. This charge can also be used in condensers with fan cycling kits, since added refrigerant is not required for mild weather control. Table 18 also contains the additional refrigerant charge required when using flooded style head pressure controls.

Combining fan cycling with flooded head pressure controls significantly reduces the amount of winter charge required to flood the condenser. Table 20 shows the refrigerant charge required when fan cycling is used in conjunction with a flooded style head pressure control.

Table 18. Refrigerant Charge, Lbs. R-22 for Flooded Condenser

Model*	Refrigerant R-22 Charge for summer Operation, Lbs.	Additional Refrigerant R-22 Charge Required for Flooded Condenser Operation Lbs. For 20°F TD Minimum Ambient at Condenser				
		+60	+40	+20	+0	-20
1	8	7	10	11	11	11
2	10	10	13	15	15	16
3	10	10	13	14	15	15
4	15	15	19	21	22	23
5	29	30	39	43	45	47
6	22	22	29	32	34	35
7	30	29	38	42	44	46
8	51	50	66	74	77	80
9	70	66	87	96	100	105
10	64	62	83	92	95	99
11	86	83	110	122	127	132
12	102	100	132	147	153	159
13	118	117	155	172	179	186
14	19	20	27	29	31	32
15	29	30	39	44	46	47
16	40	39	51	57	59	62
17	44	44	58	64	67	70
18	58	59	78	86	90	94
19	104	99	131	146	152	158
20	140	131	174	193	201	209
21	125	126	168	186	194	201
22	172	165	219	243	253	263
23	201	201	267	296	308	320
24	236	233	310	343	357	372

Table 19. Flooded Charge Temperature Difference Factor

* See Model Cross Reference Table #21.

Ambient, °F	Design T.D.				
	30	25	20	15	10
+60	---	0.38	1.0	1.74	2.46
+40	0.59	0.80	1.0	1.19	1.40
+20	0.76	0.88	1.0	1.13	1.25
0	0.84	0.91	1.0	1.07	1.16
-20	0.88	0.93	1.0	1.05	1.13

Table 20. Refrigerant Charge for Fan Cycling plus Flooded Condenser (lbs. R-22)

Model*	Summer Charge	25° TD				20° TD				15° TD				10° TD			
		40°F	20°F	0°F	-20°F	40°F	20°F	0°F	-20°F	40°F	20°F	0°F	-20°F	40°F	20°F	0°F	-20°F
1	8	7	8	9	9	8	9	10	10	9	10	11	11	13	12	12	12
2	10	9	12	13	14	11	13	14	15	13	14	15	16	17	18	17	18
3	10	1	6	8	10	4	8	10	11	7	10	12	13	10	13	14	14
4	15	2	9	12	15	7	12	15	17	12	16	18	19	17	19	21	22
5	29	4	17	24	29	14	24	30	34	24	31	36	39	33	38	41	43
6	22	0	3	10	15	0	10	16	20	0	17	22	25	0	24	27	29
7	30	0	4	13	20	0	12	20	26	0	21	27	32	0	29	34	38
8	51	0	0	8	22	0	6	23	35	0	22	38	48	0	37	52	61
9	70	0	0	11	29	0	8	31	46	0	29	51	63	0	49	71	80
10	64	0	0	0	15	0	0	17	33	0	0	39	52	0	0	60	70
11	86	0	0	0	19	0	0	22	44	0	0	50	69	0	0	78	93
12	102	0	0	0	6	0	0	8	37	0	0	37	69	0	0	66	100
13	118	0	0	0	0	0	0	0	29	0	0	0	69	0	0	0	108
14	19	3	12	17	20	9	17	21	23	15	22	25	26	21	27	29	29
15	29	4	17	24	29	13	24	30	34	22	31	36	39	31	38	41	43
16	40	5	22	32	38	17	31	39	44	29	40	46	50	41	49	53	56
17	44	0	5	20	31	0	18	31	40	0	31	42	49	0	44	53	59
18	58	0	7	27	42	0	25	42	54	0	43	57	66	0	61	71	79
19	104	0	0	17	44	0	12	47	69	0	43	77	95	0	74	107	119
20	140	0	0	22	57	0	16	62	91	0	57	102	125	0	99	141	157
21	125	0	0	0	30	0	0	34	67	0	0	77	105	0	0	120	141
22	172	0	0	0	39	0	0	44	88	0	0	100	137	0	0	156	186
23	201	0	0	0	11	0	0	16	74	0	0	74	137	0	0	132	200
24	236	0	0	0	0	0	0	0	57	0	0	0	135	0	0	0	213

* See Model Cross Reference Table #21.

Note: For other refrigerants, use the table at the right. For alternate T.D.s, multiply by flooded charge T.D. factors in Table 9.

Refrigerant	Multiply charge by:
R-134a	0.99
R-404A	0.91
R-410A	0.93

Table 21. Model Cross Reference

Model Reference	BNH	BNL	BNX	BNQ	BNE
1	BNH-S01-A007	BNL-S01-A007	BNX-S01-A006	BNQ-S01-A005	BNE-S01-A008
2	BNH-S01-A009	BNL-S01-A008	BNX-S01-A008	BNQ-S01-A006	BNE-S01-A009
3	BNH-S02-A011	BNL-S02-A010	BNX-S02-A010	BNQ-S02-A008	BNE-S02-A011
4	BNH-S02-A015	BNL-S02-A014	BNX-S02-A013	BNQ-S02-A010	BNE-S02-A015
5	BNH-S02-A017	BNL-S02-A016	BNX-S02-A015	BNQ-S02-A012	BNE-S02-A018
6	BNH-S03-A022	BNL-S03-A021	BNX-S03-A020	BNQ-S03-A016	BNE-S03-A023
7	BNH-S03-A026	BNL-S03-A024	BNX-S03-A023	BNQ-S03-A017	BNE-S03-A027
8	BNH-S04-A030	BNL-S04-A028	BNX-S04-A026	BNQ-S04-A021	BNE-S04-A031
9	BNH-S04-A034	BNL-S04-A032	BNX-S04-A030	BNQ-S04-A023	BNE-S04-A036
10	BNH-S05-A037	BNL-S05-A036	BNX-S05-A033	BNQ-S05-A026	BNE-S05-A039
11	BNH-S05-A044	BNL-S05-A042	BNX-S05-A038	BNQ-S05-A029	BNE-S05-A047
12	BNH-S06-A053	BNL-S06-A050	BNX-S06-A045	BNQ-S06-A034	BNE-S06-A056
13	BNH-S07-A061	BNL-S07-A055	BNX-S07-A052	BNQ-S07-A042	BNE-S07-A065
14	BNH-D04-A021	BNL-D04-A020	BNX-D04-A020	BNQ-D04-A016	BNE-D04-A023
15	BNH-D04-A029	BNL-D04-A028	BNX-D04-A026	BNQ-D04-A021	BNE-D04-A031
16	BNH-D04-A034	BNL-D04-A032	BNX-D04-A030	BNQ-D04-A023	BNE-D04-A036
17	BNH-D06-A044	BNL-D06-A042	BNX-D06-A040	BNQ-D06-A031	BNE-D06-A046
18	BNH-D06-A051	BNL-D06-A048	BNX-D06-A045	BNQ-D06-A034	BNE-D06-A054
19	BNH-D08-A058	BNL-D08-A056	BNX-D08-A053	BNQ-D08-A041	BNE-D08-A062
20	BNH-D08-A068	BNL-D08-A065	BNX-D08-A061	BNQ-D08-A046	BNE-D08-A073
21	BNH-D10-A074	BNL-D10-A071	BNX-D10-A066	BNQ-D10-A052	BNE-D10-A079
22	BNH-D10-A088	BNL-D10-A083	BNX-D10-A076	BNQ-D10-A057	BNE-D10-A093
23	BNH-D12-A106	BNL-D12-A100	BNX-D12-A091	BNQ-D12-A069	BNE-D12-A112
24	BNH-D14-A123	BNL-D14-A110	BNX-D14-A104	BNQ-D14-A083	BNE-D14-A129

Calculate Refrigerant Charge

Refrigeration operating charges are located in Table 18 for flooded condenser and Table 20 for fan cycling plus flooded condenser.

Charge for flooded condenser = summer charge (Table 18) + additional flooding charge (Table 18) * flooded charge T.D. factor (Table 19)

Charge for fan cycling + flooding = summer charge (Table 20) + additional charge for fan cycling (Table 20)

Example:

Obtain the summer charge for a BNH-S05-A037. What is the flooding charge required to operate this condenser at 0° ambient at a 20°T.D. with R-22 refrigerant? What is the reduction in operating charge if fan cycling is combined with flooding?

Procedure:

From Table 18, obtain the summer operating charge for a BNH-S05-A037 of 64 lbs. The charge for winter operation with flooded controls is equal to the summer operating charge of 64 lbs. plus the additional charge at 0° ambient (Table 18) of 95 lbs., times the flooded charge T.D. factor (Table 19) of 1.0 for 20°T.D.

$$\begin{aligned} \text{Charge for flooded condenser} &= 64 + (95) * 1.0 \\ &= 159 \text{ lbs.} \end{aligned}$$

The charge for fan cycling plus flooded condenser is obtained using Table 20. Using this table obtain the additional charge for 20°T.D. at 0° ambient, which is 17 lbs. The total charge is the summer charge (64 lbs.) plus the additional charge.

$$\begin{aligned} \text{Charge for fan cycle + flooding} &= 64 + 17 \\ &= 81 \text{ lbs.} \end{aligned}$$

$$\begin{aligned} \text{The savings in refrigerant charge} &= 159 - 81 \\ &= 78 \text{ lbs.} \end{aligned}$$

Diagram 1. Typical Condenser Wiring Diagram With No Fan Cycle Controls

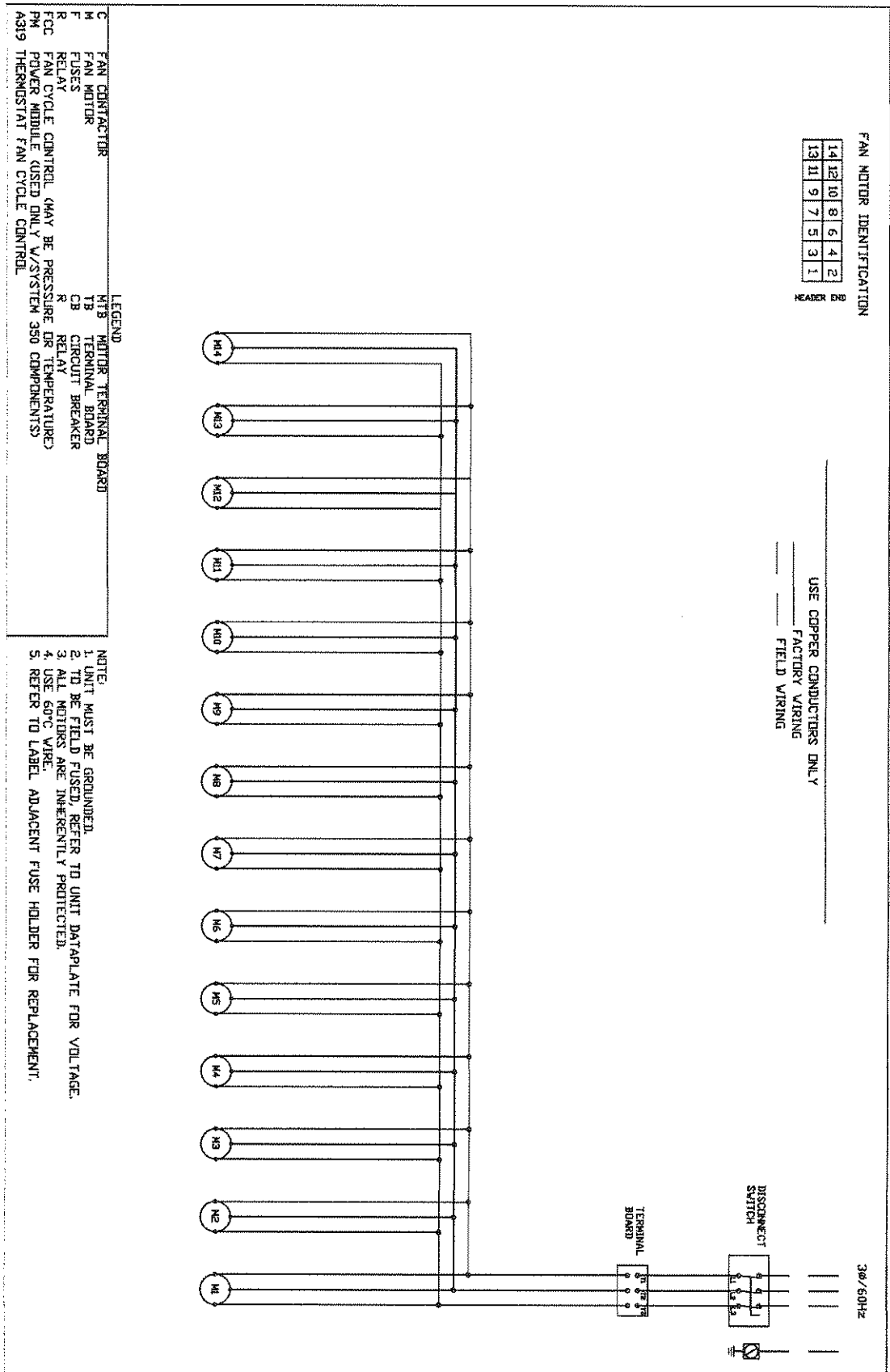
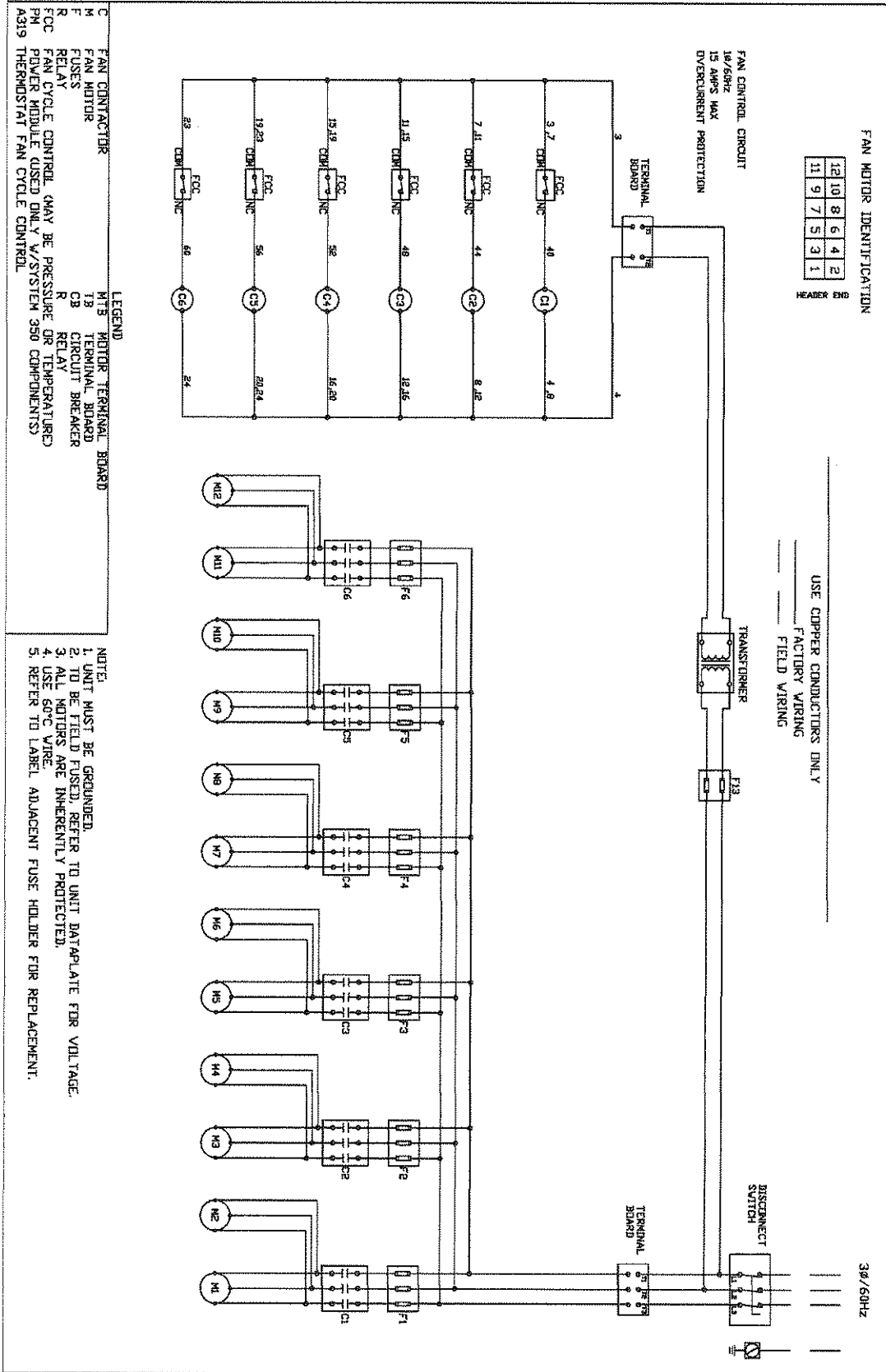
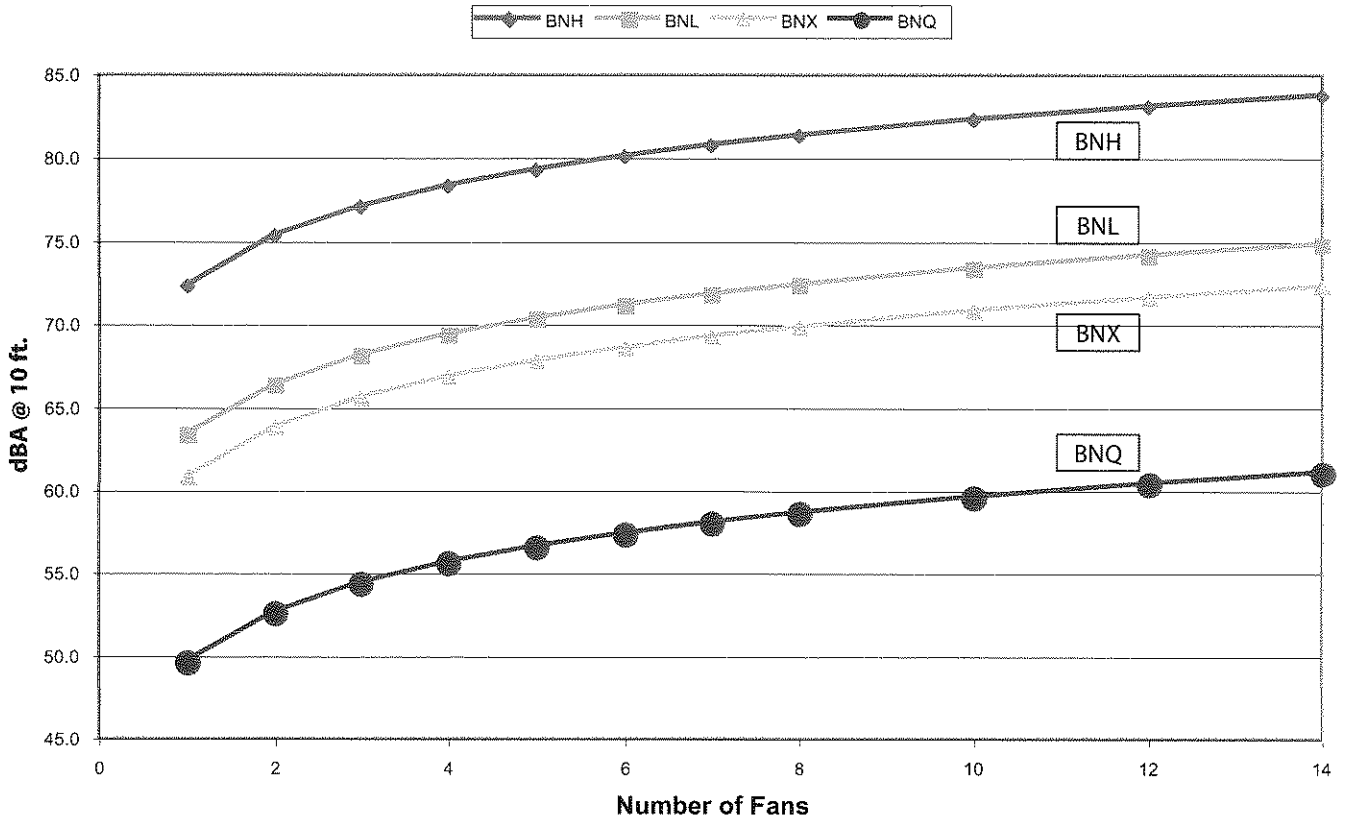

Diagram 2. Typical Condenser Wiring Diagram With Fan Cycle Controls



Sound Data for Ambassador and 1140 Series

Unit Sound Data (dBA @ 10 ft.)



Unit Sound Data (dBA @ 10 ft.)

Fans	BNH	BNL	BNX	BNQ
1	72.3	63.4	60.8	49.6
2	75.3	66.4	63.8	52.6
3	77.1	68.1	65.6	54.4
4	78.3	69.4	66.8	55.6
5	79.3	70.3	67.8	56.6
6	80.1	71.1	68.6	57.4
7	80.8	71.8	69.3	58.1
8	81.3	72.4	69.8	58.6
10	82.3	73.4	70.8	59.6
12	83.1	74.1	71.6	60.4
14	83.8	74.8	72.3	61.1



Visit www.thecoldstandard.com
for technical literature online.

BOHN
THE COLD STANDARD

A Brand of Heatcraft Refrigeration Products, LLC
2175 West Park Place Blvd. • Stone Mountain, GA • 30087
770.465.5600 • FAX 770.465.5990

www.thecoldstandard.com

AIR HANDLING UNIT SCHEDULE

MARK	MANUFACTURER	MODEL	SUPPLY FAN OPERATION		OUTSIDE AIR CFM	GAS HEAT SUPPLY INPUT (MBH)
			CFM	ESP		
AHU1	MUNTERS	HCUC6030AAD	5000	0.5"	CONTINUOUS	800
AHU2						
AHU3						

GENERAL INFORMATION (ALL UNITS):

1. UNIT FURNISHED BY OWNER, INSTALLED BY MECHANICAL CONTRACTOR.
2. ALL UNITS ARE 460V, 3 PHASE, 60 HERTZ. UNITS MUST BE UL OR ETL AS WELL AS AGA APPROVED.
MINIMUM AFUE = 80%.
3. UNIT OPERATING WEIGHT (LBS): 5,600.
4. OUTSIDE AIR IS CONDITIONED THROUGH THE AIR HANDLING UNITS FOR THE SALES FLOOR AREA IN ACCORDANCE WITH ASHRAE 62.1-2004.
5. UNIT ENERGY EFFICIENCY RATING (EER) PER ARI 210 AND 360: EER = 11.1
6. ROOF CURB FURNISHED BY OWNER. REFER TO SPECIFICATIONS.
7. UNITS ARE PROVIDED WITH FACTORY INSTALLED CONVENIENCE RECEPTACLE.
8. INSTALL ANCHOR BRACKETS FURNISHED WITH ROOF CURB. REF HVAC SEISMIC/WIND RESTRAINT BRACKET DETAIL.
9. SUPPLY AIR SMOKE DETECTOR SHIPPED LOOSE WITH EQUIPMENT FOR INSTALLATION BY CONTRACTOR PER AUTHORITY HAVING JURISDICTION.

05.29.09

REV.	DESCRIPTION	BY	DATE	CHKD.	DATE	E.C.O. NO.
03	ADDED CORNER WEIGHTS, COG, CHANGED WEIGHTS	MGY	02/13/05	MGY	02/13/05	
571072-000						

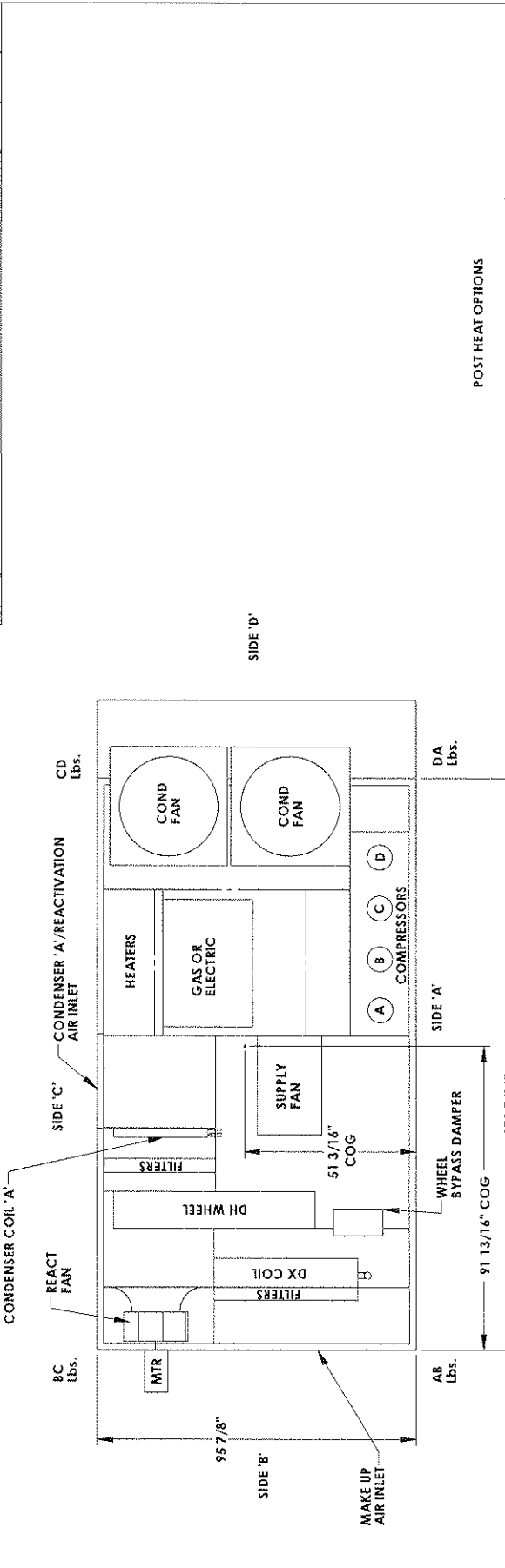

POST HEAT OPTIONS

	AB	BC	CD	DA	UNIT WEIGHT
NO MBH	1,271	1,347	1,274	1,358	5,250
400 MBH	1,271	1,347	1,449	1,348	5,415
800 MBH	1,271	1,347	1,644	1,338	5,600
ELE. HTR	1,271	1,347	1,644	1,338	5,600

SIDE CLEARANCES:
 SIDE 'A' = 48"
 SIDE 'B' = 48"
 SIDE 'C' = 40"
 SIDE 'D' = 48"

PRELIMINARY DRAWING
 DRAWING SUBJECT TO REVISIONS

CONFIDENTIALITY STATEMENT
 THE TECHNICAL INFORMATION AND DESIGN DATA DISCLOSED HEREIN CONSTITUTE PROPRIETARY INFORMATION OF MUNTERS. THIS INFORMATION IS NOT TO BE LOANED, REPRODUCED, COPIED, OR USED FOR THE DESIGN OF ANY EQUIPMENT WITHOUT THE WRITTEN PERMISSION OF MUNTERS.

Munters
 HCUC 6000 WALMART

Drawn by: MGY
 Checked by: R PAUTZ
 Date: 12/09/05
 Date: 12-13-05

Sheet: 1 of 3
 Part Number: 571072-000

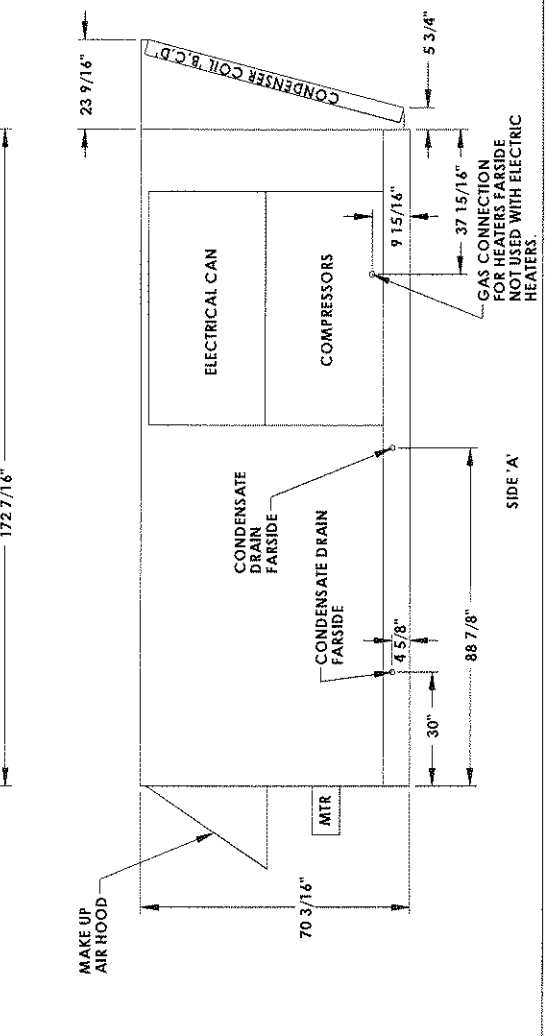

REV.	DESCRIPTION	BY	CHKD.	DATE	E.C.O. NO.
	S71072-000				

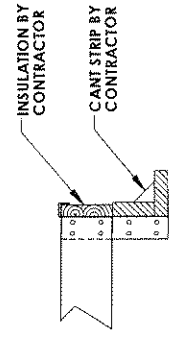
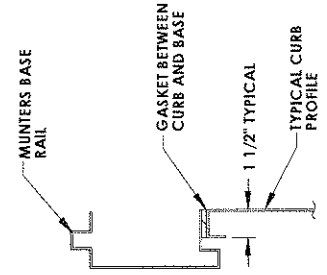
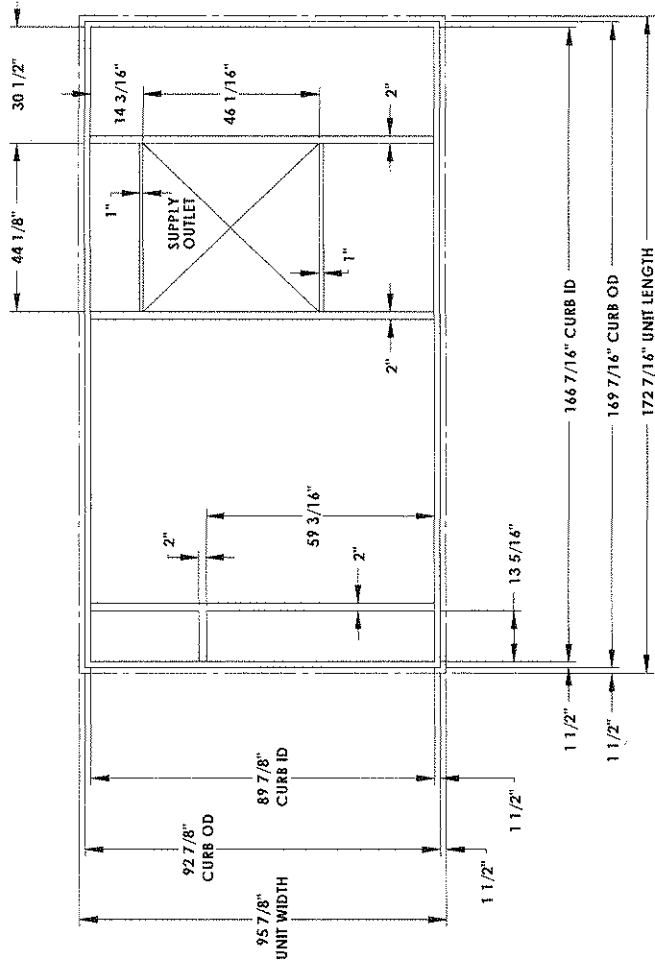

ROOF CURB TO BE BROKEN DOWN FOR SHIPPING UNLESS AUTHORIZED BY CUSTOMER TO BE SHIPPED ASSEMBLED.

<p>CONFIDENTIALITY STATEMENT</p> <p>THE TECHNICAL INFORMATION AND DESIGN DATA DEPICTED HEREIN CONSTITUTE PROPRIETARY INFORMATION OF MUNTERS. THIS INFORMATION IS FOR THE SOLE USE OF OUR CUSTOMER AND IS NOT TO BE REPRODUCED OR TRANSMITTED IN ANY FORM OR BY ANY MEANS, ELECTRONIC OR MECHANICAL, INCLUDING PHOTOCOPYING, RECORDING, OR BY ANY INFORMATION STORAGE AND RETRIEVAL SYSTEM.</p>	
<p>Munters</p>	
<p>ROOF CURB INFORMATION</p>	
<p>DRAWING TITLE: ROOF CURB INFORMATION</p>	
<p>SCALE: 3/8" = 1"</p>	
<p>DATE: 05/11/2011</p>	
<p>PROJECT: S71072-000</p>	
<p>SHEET: 8 OF 8</p>	

REV.	DESCRIPTION	BY	CHKD.	DATE	E.C.O.	NO.

S71072-000

CAUTION ATTENTION RIGGER

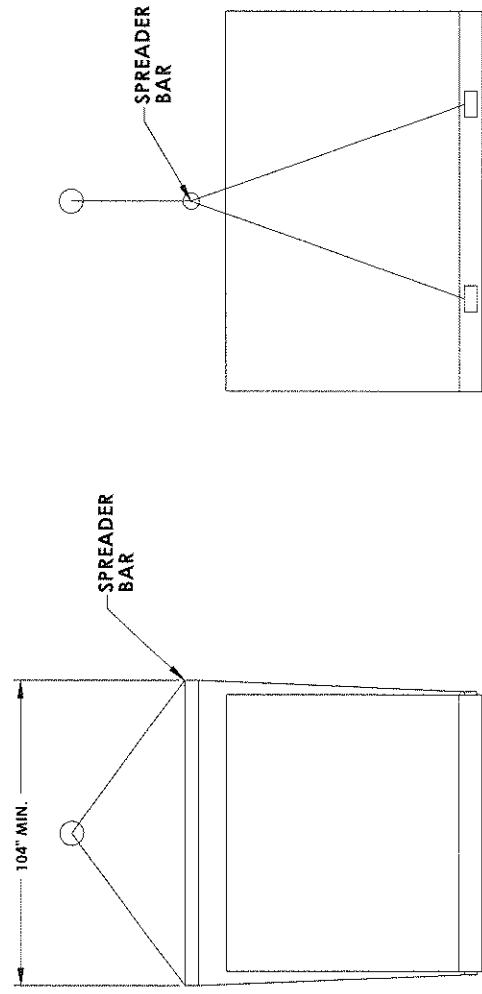

NOTES:
 LIFT ONLY USING SUPPLIED LIFTING LUGS.
 CRANE AND RIGGING MUST BE CAPABLE
 OF HANDLING 5,600 LBS ± 10% LOAD.
 SPREADER BAR MUST BE USED TO PREVENT
 RIGGING CABLES FROM SQUEEZING IN TOP
 OF UNIT. SPREADER BAR MUST BE A MINIMUM
 OF 104" BETWEEN LOWER CABLE ATTACHMENT
 POINTS. UNIT MUST BE RIGGED USING ALL 4
 LIFTING LUGS (2 PER SIDE) OR SEVERE DAMAGE
 MAY RESULT.

CONFIDENTIALITY STATEMENT
 THE TECHNICAL INFORMATION AND DESIGN DATA DEPICTED HEREIN CONSTITUTE PROPRIETARY INFORMATION OF MUNTERS. THIS INFORMATION IS FOR THE SOLE USE OF OUR CUSTOMERS AND END USERS OF OUR EQUIPMENT.

Munters
 DRAWING TITLE:
RIGGING INSTRUCTIONS

ALL DIMENSIONS ARE IN INCHES
 UNLESS OTHERWISE SPECIFIED
 FRACTIONS: DECIMALS ANGLES
 ± .125 ± .005 ± 1/2 Deg

DATE: 3.06.3. DRAWING NUMBER: S71072-000



Test Report: MLR 06.008

Date: 10/3/2006

Purpose:

To document the sound emitted from the unit at 15'.

Item Under Test:

HCUc prototype unit (MY806652)

Equipment:

1 Larson Davis, LxT, Sound Meter

Test Setup:

- 1 The unit is sitting outside on stands, 16" off the ground.
- 2 Reading were taken 4' from the ground and 15' from the unit.

Data:

Date/Time: 10/3/06 @ 8:00 am, Ambient: 77°F, 83% RH,

- 1 Unit with 1 of the condensor fans running (dBA & octave band level)
- 2 Unit with both of the condensor fans running (dBA & octave band level)
- 3 Unit off (dBA & octave band level)

dBA	67	70	62
hz	1Fan	2Fan	Off
8	58	60	60
16	64	63	64
31	69	74	67
63	76	76	67
125	70	76	63
250	66	70	59
500	66	69	58
1k	64	66	61
2k	58	61	55
4k	57	58	55
8k	55	55	55
16k	55	55	55

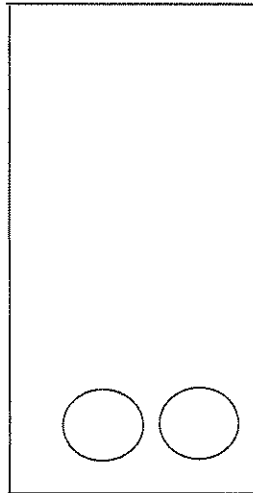

dBA	68	70	59
hz	1Fan	2Fan	Off
8	61	62	60
16	66	63	64
31	65	69	66
63	70	72	66
125	71	78	60
250	68	71	59
500	67	68	57
1k	60	63	56
2k	57	60	55
4k	55	56	55
8k	55	55	55
16k	55	55	55

dBA	74	77	63
hz	1Fan	2Fan	Off
8	62	63	61
16	67	64	64
31	75	73	68
63	74	79	65
125	72	77	61
250	74	76	61
500	69	71	61
1k	66	68	56
2k	61	62	55
4k	57	57	55
8k	57	58	55
16k	60	61	55



**ADVANCE
ENGINEERING DATA**

**PACKAGED GAS / ELECTRIC
STRATEGOS™
ROOFTOP UNITS (R-410A)
60 HZ**

Bulletin No. 210491
April 2007

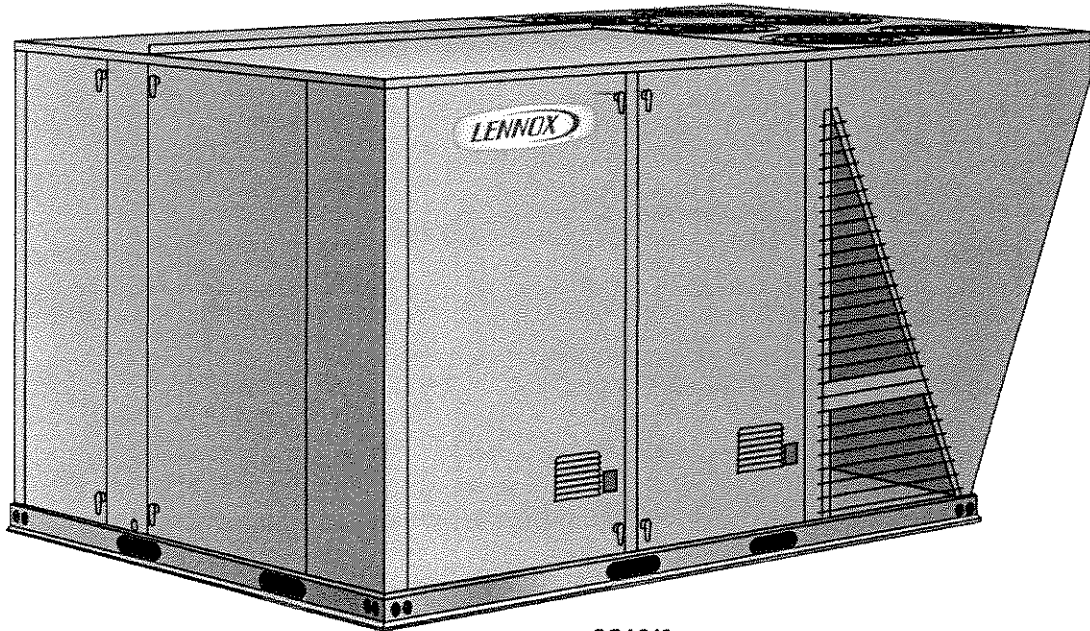

SGA240

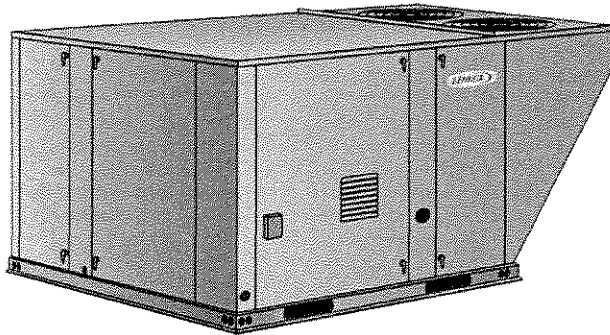

SGA060

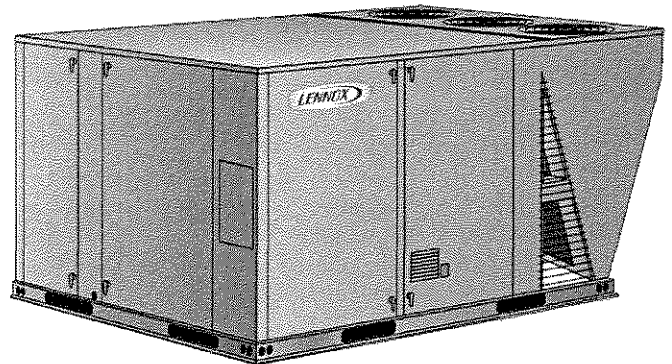

SGA120



ASHRAE 90.1
COMPLIANT



**3 to 20 Tons
Net Cooling Capacity - 36,000 to 236,000 Btuh
Gas Input Heat Capacity - 75,000 to 480,000 Btuh**

MODEL NUMBER IDENTIFICATION

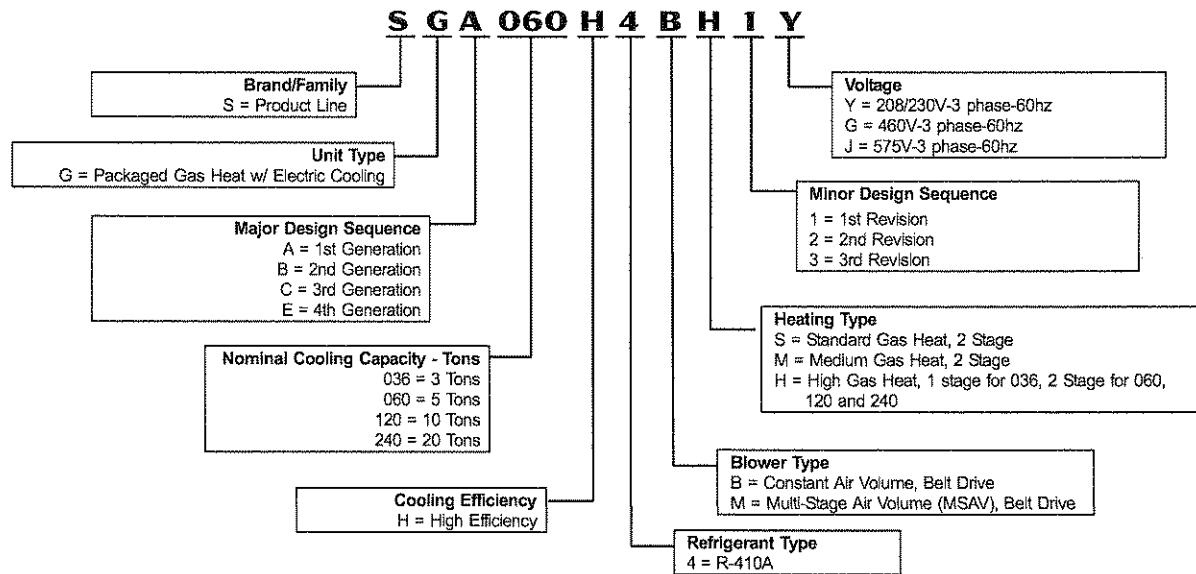

CONTENTS

Blower Performance	Pages 22-24
Cooling Ratings	Pages 20-22
Dimensions	Pages 28-33
Electrical Data	Page 25
Features and Benefits	Pages 2-6
Guide Specifications	Pages 34-46
High Altitude Information	Page 25
Model Number Identification	Page 2
Options / Accessories	Pages 7-8
Sequence of Operation	Pages 9-15
Specifications	Pages 16-18
Specifications - Integrated Modular Controller (IMC)	Page 19
Sound Data	Page 26
Unit Clearances	Page 26
Weights	Page 27

FEATURES AND BENEFITS

APPROVALS

ETL and CSA listed.
 Efficiency rating verified by GAMA (US) and CSA certified (Canada).
 Components bonded for grounding to meet safety standards for servicing required by UL, ULC and National and Canadian Electrical Codes.
 3 and 5 ton models are certified in accordance with the USE certification program, which is based on ARI Standard 210/240-2005.
 10 and 20 ton CAV models are certified in accordance with the ULE certification program, which is based on ARI Standard 340/360-2004.
 10 and 20 ton MSAV models are rated at test conditions included in ARI Standard 340/360-2004 while operating at rated voltage and air volumes.
 ENERGY STAR® certified units are designed to use less energy, help save money on utility bills, and help protect the environment.

The ENERGY STAR® Partner of the Year Award signifies that Lennox has made outstanding contributions to design energy efficient units that will lower energy bills, while meeting industry standards for comfort and indoor air quality. Lennox was the first HVAC manufacturer to win this award and has been a four-time recipient since 2003.

WARRANTY

Limited ten years aluminized heat exchanger, limited fifteen years optional stainless steel heat exchanger.
 Limited five years on compressors.
 Limited three years on Integrated Modular Controller.
 Limited one year all other covered components.

FEATURES AND BENEFITS

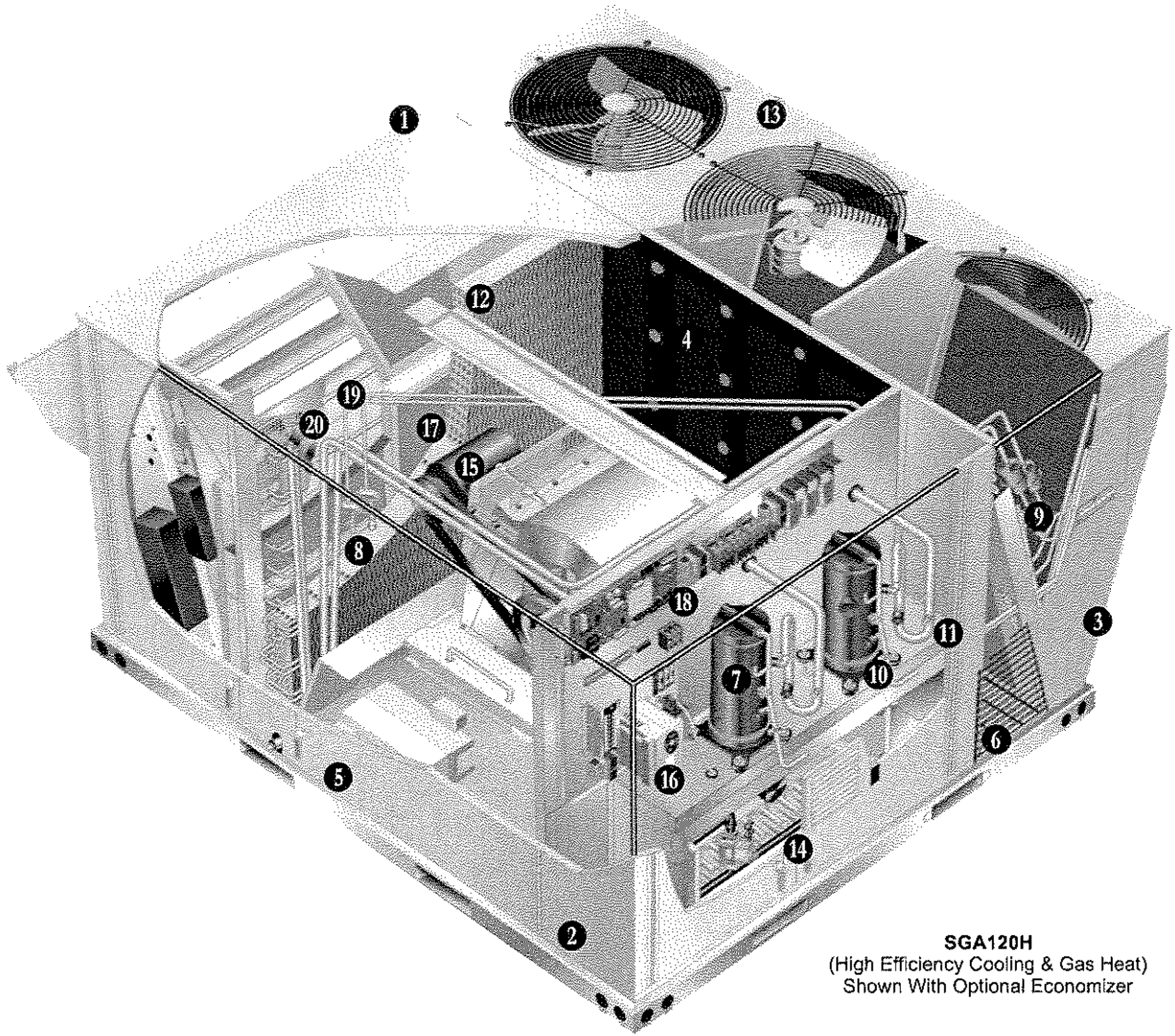

SGA120H
 (High Efficiency Cooling & Gas Heat)
 Shown With Optional Economizer

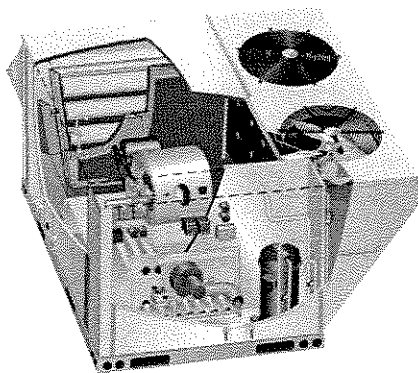

SGA060H
 (High Efficiency Cooling & Gas Heat)
 Shown With Optional Economizer

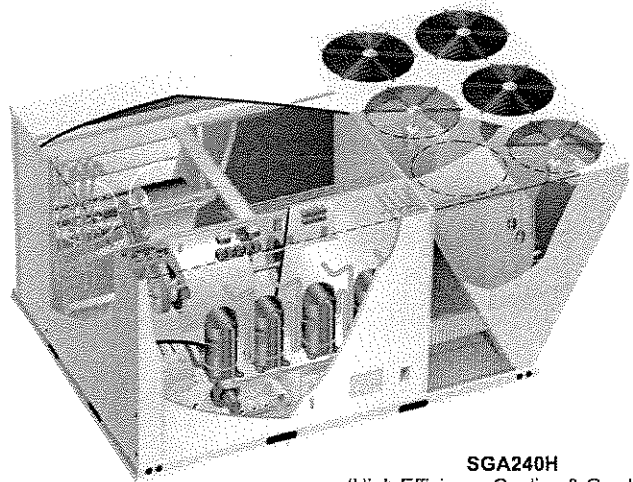

SGA240H
 (High Efficiency Cooling & Gas Heat)
 Shown With Optional Economizer

FEATURES AND BENEFITS

CABINET

- 1 Construction**

Heavy-gauge steel panels and full perimeter heavy-gauge galvanized steel base rail provides structural integrity for transportation, handling, and installation. Base rails have rigging holes. Base rails have fork slots, two sides on the 3 and 5 ton models and three sides on the 10 and 20 ton models. Raised edges around duct and power entry openings in the bottom of the unit provide additional protection against water entering the building.
- Air-Flow**

Units are shipped in down-flow (vertical) configuration.
- 2 Power/Gas Entry**

Electrical or gas lines can be brought through the unit base or through horizontal access knock-outs.
- 3 Exterior Panels**

Constructed of heavy-gauge, galvanized steel with a two-layer enamel paint finish.
- 4 Insulation**

All panels adjacent to conditioned air are fully insulated with non-hygroscopic fiberglass insulation. Unit base is fully insulated. The insulation also serves as an air seal to the roof curb, eliminating the need to add a seal during installation.
- 5 Access Panels**

Hinged access panels are provided for the economizer/filter section, blower section, and compressor/controls/heat section. Hinges are constructed of painted, stainless-steel. All hinged panels have seals and quarter-turn latching handles to provide a tight air and water seal.
- 6 Grille Guards**

Protects space between outdoor coils and main cabinet.

OPTIONS/ACCESSORIES

Factory Installed

Corrosion Protection

Polymeric epoxy coating that is deposited by electrical transport (electrophoresis), using a process known as electrocoat (e-coat). Available for enhanced coil corrosion protection. The condenser option includes the coil coating only. The evaporator option includes the coil coating and includes painting of the following assemblies: blower assembly, evaporator base assembly and the blower support walls. Factory installed on the condenser coil, evaporator coil, or both.

COOLING SYSTEM

Designed to maximize sensible and latent cooling performance at design conditions. System can operate from 0°F to 125°F without any additional controls.

- 7 Compressor**

Resiliently mounted on rubber grommets for quiet operation. Scroll compressors on all models for high performance, reliability, and quiet operation.

Compressor Crankcase Heater
Protects against refrigerant migration that can occur during low ambient operation. The heater is thermostatically controlled to save energy.
- 8 Thermal Expansion Valve (TXV)**

Assures optimal performance throughout the application range. Removable element head.
- 9 Filter/Drier**

Solid core, molecular-sieve, high capacity filter/drier protects the system from dirt and moisture.
- 10 High Pressure Switch**

Protects the compressor from overload conditions such as dirty condenser coils, blocked refrigerant flow, or loss of outdoor fan operation.
- 11 Low Pressure Switch**

Protects the compressor from low pressure conditions such as low refrigerant charge, or low/no air flow.

Freezestat
Protects the evaporator coil from damaging ice build-up due to conditions such as low/no air flow, or low/no refrigerant charge.

Low Ambient Pressure Switches
Allows unit to cycle a portion of the condenser fan motors based on liquid line pressure enabling reliable cooling operation down to 0°F outdoor ambient.
- 12 Coil Construction**

Copper tube construction, enhanced rippled-edge aluminum fins, flared shoulder tubing connections, silver soldered construction for improved heat transfer. Factory leak tested.

Evaporator Coil
Face split coils on constant air volume models. Row split coils on multi-stage air volume models. Cross row circuiting with rifled copper tubing optimizes both sensible and latent cooling capacity.

Condenser Coil
One slab coil on 3-5 ton models, two slab coils on 10-ton models and four slab coils on 20-Ton models. Pre-painted, galvanized steel condenser divider wall and condenser base.

Condensate Drain Pan
Painted, galvanized pan with positive slope. Drain connection extends outside unit.
- 13 Outdoor Coil Fan Motors**

Thermal overload protected, totally enclosed, permanently lubricated ball bearings, shaft up, wire basket mount.

Outdoor Coil Fan
PVC coated fan guard furnished.

Refrigerant

Non-chlorine, ozone friendly, R-410A. Unit pre-charged with refrigerant.

REQUIRED SELECTIONS

Cooling Capacity

Specify nominal cooling capacity of the unit.

HEATING SYSTEM

- 14** Aluminized steel inshot burners, direct spark ignition, electronic flame sensor, combustion air inducer, redundant automatic single or dual stage gas valve with manual shut-off.

Heat Exchanger

Patented, dimple-design, tubular construction, aluminized steel, life-cycle tested.

Stainless Steel Heat Exchanger is required if mixed air temperature is below 45°F.

Limit Controls

Factory installed limit controls with fixed temperature setting.

Heat limit controls protect heat exchanger and other components from overheating.

Safety Switches

Flame roll-out switch, flame sensor and combustion air inducer proving switch protect system operation.

All safety switches are monitored by the IMC (Integrated Modular Controller) unit controller and diagnostic errors are reported and recorded.

REQUIRED SELECTIONS

Gas Input Choice - Order one:

3 ton models:

75 kBtuh High Gas Heat, 1 Stage

5 ton models:

81/125 kBtuh High Gas Heat, 2 Stage

10 ton models:

84.5/130 kBtuh Standard Heat Gas Input

117/180 kBtuh Medium Heat Gas Input

156/240 kBtuh High Heat Gas Input

20 ton models:

169/260 kBtuh Standard Heat Gas Input

234/360 kBtuh Medium Heat Gas Input

312/480 kBtuh High Heat Gas Input

Gas Type

Specify Natural Gas or LPG/Propane Gas.

OPTIONS/ACCESSORIES

Factory Installed

Stainless Steel Heat Exchanger

Required if mixed air temperature is below 45°F.

Field Installed

Fresh Air Tempering

Provides heating and cooling as needed to maintain the supply air temperature within a comfort range, regardless of the thermostat demand. Requires field installed sensor kit and IMC (ECTO) parameter change in the field to activate this mode of operation.

FEATURES AND BENEFITS

BLOWER

- 15 Motor**
Overload protected, equipped with ball bearings.
- Supply Air Blower**
Forward curved blades, blower wheel is statically and dynamically balanced.
- Blower Proving Switch**
Monitors blower operation, shuts down unit if blower fails.

REQUIRED SELECTIONS

Select Constant Air Volume or Multi-Stage Air Volume

On Constant Air Volume (CAV) models (all models), the supply fan will provide a constant volume of air.

On Multi-Stage Air Volume (MSAV) (10 and 20 ton models only), the supply fan will stage the amount of airflow according to compressor stages, heating demand, ventilation demand or smoke alarm. Utilizes a variable frequency drive (VFD) to stage the supply fan airflow.

- 16** The VFD alters the frequency and voltage of the power supply to the blower to control blower speed.
The amount of airflow for each stage can be set according to an ECTO parameter in the unit's IMC. Unit is shipped from the factory with preset airflow. See Sequence of Operation for details.
The VFD has an operational range of 0 to 125°F outdoor air ambient temperature. Lower operating costs are obtained when the blower is operated on lower speeds.

ELECTRICAL

Circuit Breakers

HACR type. For overload and short circuit protection. Factory wired and mounted in the power entry panel. Current sensitive and temperature activated. Manual reset.

GFI Service Outlets (2)

115V ground fault circuit interrupter (GFCI) type.

REQUIRED SELECTIONS

Voltage Choice

Specify when ordering base unit.

INDOOR AIR QUALITY

- 17 Air Filters**
Pre-painted, galvanized steel filter racks. Filter racks can be converted to use four inch thick filters.
Disposable 2 inch pleated MERV 7 filters (Minimum Efficiency Reporting Value based on ASHRAE 52.2).

OPTIONS/ACCESSORIES

Field Installed

Indoor Air Quality (CO₂) Sensor

Monitors CO₂ levels, reports to IMC board which adjusts economizer dampers as needed.

MSAV units with an economizer require a CO₂ sensor to modulate the economizer damper and maintain the desired minimum amount of fresh outdoor air. CO₂ sensor can be installed in either the occupied zone or the return air duct.

SERVICEABILITY

Designed to streamline general maintenance and decrease troubleshooting time.

Diagnostics

IMC diagnostic codes pinpoint problems, minimizing troubleshooting time.

Marked & Color-Coded Refrigerant Circuits (10 & 20 Ton Models)

Refrigerant circuits are color-coded and marked to identify which components belong to which circuit.

Marked & Color-Coded Wiring

All electrical wiring is color-coded and marked to identify which components are being connected.

Electrical Plugs

Positive connection electrical plugs are used to connect common accessories or maintenance parts for easy removal or installation.

Toolless, Hinged Access Panels

Large access panels are hinged and have quarter-turn, latching handles for quick and easy access to maintenance areas (economizer / filter, compressor / controls / heating, blower).

Blower Access

Supply air blower parts are located near the access door for easy servicing and adjustment. Blower assembly slides out of the unit for easy access without disconnecting the wiring harness.

Thermal Expansion Valves (TXV)

Thermal expansion valves are located near the perimeter of the unit for easier access.

Removable element head allows change out of element and bulb without removing the TXV.

Coil Cleaning

Slab coils allow for easy cleaning. Hinged doors at each end of the coil compartment allow access to clean coils from the inside.

Standard Components

A large number of common maintenance parts are standard throughout the entire range of sizes (3-20 tons), reducing the need to carry a lot of different parts to the job or maintain in inventory.

Compressor Compartment

Compressors are located near the perimeter of the unit for easier access. Compressors are isolated from the condenser air flow allowing system operation checks to be done without changing the air flow across the outdoor coils.

CONTROLS

18 INTEGRATED MODULAR CONTROLLER (IMC)

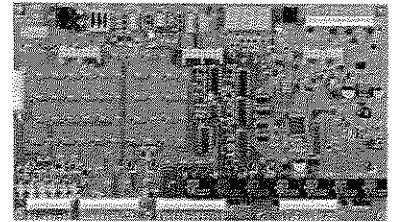

The Integrated Modular Controller (IMC) is a microprocessor-based control board that provides flexible control of many unit functions.

All control voltage is provided via a 24V (secondary) transformer with built-in circuit breaker protection.

Built-in functions include:

Control Modes

Thermostat Mode - Used with third party DDC or thermostat. Provides economizer and up to 2 stages of heating and 2 stages of cooling operation. On MSAV units, capable of supporting up to 5 supply air fan speeds (2 cooling, 1 heating, 1 ventilation, 1 smoke detector).

Zone Sensor Mode - Controls zone temperature with up to 4 stages of heating and 4 stages of cooling with optional zone sensor. On MSAV equipped units, capable of supporting up to 7 supply air fan speeds (4 cooling, 1 heating, 1 ventilation, 1 smoke detector).

Display, Diagnostics, and Configuration ECTO (Electronic Configure-to-Order) Control Parameters

- Over 200 different control parameters allow customization of the unit operation by changing delays, cooling / heating stages, deadbands, and setpoints.

Extensive Unit Diagnostics - The IMC monitors all sensors and functions related to unit operation to provide critical information. The IMC will display diagnostic information with over 100 diagnostic codes to pinpoint any problems and reduce troubleshooting time. All diagnostic codes are listed inside the control access panel for easy reference. Diagnostic codes are stored through a power failure.

On-Board User Interface - Displays control parameters, diagnostic codes, and sensor readings. The IMC unit controller displays temperature readings from return air, supply air, and outdoor air sensors that are furnished standard. IMC will also display readings from optional sensors such as zone sensors, CO₂ sensors or relative humidity sensors. Push-button and DIP switches are used with three-digit display readout for field adjustment of control parameters. LED's indicate L Connection[®] Network transmit and receive and thermostat input status.

Network Capable - The IMC can be daisy chained to other IMC-equipped units or L Connection Network controllers using twisted pair wire.

FEATURES AND BENEFITS

CONTROLS

INTEGRATED MODULAR CONTROLLER

Safety, Reliability and Serviceability

“Strike Three” Protection - Ends cooling or heating operation when any of the following occurs three times within a thermostat cycle: low pressure trip, high pressure trip, heat limit trip, or freestat trip.

Smoke Alarm Mode - Control board has five choices for responding to a smoke alarm.

1. Unit off (Default)
2. Positive Pressure - Blower on, exhaust fan off, OD air damper open.
3. Negative Pressure 1- Blower on, exhaust fan on, OD air damper closed.
4. Purge - Blower on, exhaust fan on, OD air damper open.
5. Negative Pressure 2- Blower off, exhaust fan on, OD air damper closed.

Minimum Compressor Run Time - Ensures proper oil return to the compressor.

Thermostat Bounce Delay - Protects compressor from short-cycling when mechanical thermostat is used.

Safety Switch Input - Normally-closed digital input allows the IMC to respond to an external safety switch trip (low voltage, etc.) shutting down unit operation.

Low Ambient Control - Allows unit cooling operation down to 0°F.

Service Relay Output - Digital output can be communicated to an external device indicating an error has occurred. Can also be configured to energize based on relative humidity, indoor air quality, outdoor air temperature, or unit operation.

Comfort, Efficiency, and Indoor Air Quality

Staging - Up to 2 heat/2 cool in thermostat mode, up to 4 heat/4 cool in zone sensor mode.

Economizer Control - The economizer is controlled by an add-on board to the IMC. Sensors must be field provided. See Sequence of Operation section for details.

Fresh Air Tempering - Provides heating and cooling as needed to maintain the supply air temperature within a comfort range regardless of the thermostat demand. Requires field installed return air sensor. Requires change to IMC (ECTO) parameter in the field.

Warm-up Mode Delay - Adjustable time that the economizer dampers are kept in the closed position during morning warm-up.

Indoor Air Quality Input - The IMC is Demand Control Ventilation ready from the factory (optional field installed CO₂ sensor required). Two modes of operation are available: setpoint and proportional.

1 - Setpoint - Opens the economizer dampers to set position when CO₂ setpoint level is reached.

2 - Proportional - Opens the dampers at the first setpoint and gradually increases it as the CO₂ level increases until the second setpoint is reached.

Exhaust Fan Control - Fans controlled by fresh air damper position.

Load-Shedding Options - There are two Load-Shedding options available in the IMC.

Partial Mechanical Cooling Lockout - The IMC can be configured to disallow half of the mechanical cooling on two or four compressors, one-third or two-thirds of mechanical cooling on three compressors or all mechanical cooling on single compressors by energizing a 24VAC digital input.

Whole Unit Lockout - The IMC can also shutdown the whole unit by de-energizing a 24VAC digital input.

Night Setback Mode - Adjusts setpoints, closes outdoor air dampers and operates the blower on demand, may be customized for special requirements.

Return Air Temperature Limit Control - Option to override the demand based upon the return air temperature during either heating or cooling operation. Helps protect against abnormal operating conditions.

Gas Valve Time Delay Between First and Second Stage - Allows gradual increase of input rate.

OPTIONS / ACCESSORIES

Factory Installed

Smoke Detector

Installed in supply air section or return air section or both sections. Requires 115V external power source.

Factory or Field Installed

Third-Party DDC

Novar® ETM-2024, Danfoss RTC, and CPC Multiflex 810-3062 controllers are available.

The DDC options include the following components:

Rooftop Controller

Discharge Air Temperature Sensor

Return Air Temperature Sensor

Wiring Harnesses

Mounting Hardware

Contact respective manufacturers for controller details.

Field Installed

L Connection® Network

See L Connection Network Engineering Handbook Bulletin for details.

Unit Controller PC Software

Allows user the option to set-up, monitor, and diagnose rooftop units from their PC. Allows the user to set-up or change the Electronic Configure to Order (ECTO) parameters, view alarm codes, view unit status, test unit, and print/save reports. Requires one of the following:

PC Connector Kit

An EIA-232 to Lennox SysBus and ZoneBus data converter. Powered from the PC serial port through the 9-pin connector. Includes two Lennox network connectors, a phone jack and a two-position screw terminal block.

Ethernet Converter

Allows the user to monitor and control devices on the L Connection Network from any PC on the LAN or via the Internet. LED indicators monitor traffic flow and diagnostics. Kit includes: Ethernet converter, 6 ft. Ethernet patch cable, modem converter, and power transformer.

Network Modem Kit

Allows remote access to the network via the L Connection Network PC software. Network transmit, receive and connect LEDs. Kit includes phone modem, network modem converter, wall mount transformer and phone cable.

Systems Integration

The IMC can be directly integrated into Novar Lingo® or Savvy® systems using the Logic One System Enhancer (LSE) furnished by Novar.

The IMC can also be directly integrated into the CPC Einstein E2BX panel with software furnished by CPC.

Both of these systems integration options allow access to all diagnostic information from the IMC and the most commonly used setpoints and control information via their respective interfaces. Contact respective manufacturers for details.

OPTIONS / ACCESSORIES

ECONOMIZER/OUTDOOR AIR

Factory Installed

19 Economizer with Barometric Relief Dampers

Economizer features:

Parallel gear driven action return air and outdoor air dampers, plug-in connections to unit, nylon bearings, neoprene seals, 24 volt fully-modulating, spring-return motor, adjustable minimum damper position, damper assembly slides in unit, swing-out hood included.

Barometric Relief Damper features:

Allows relief of excess air, dampers prevent blow back and outdoor air infiltration during off cycle, and bird screen.

The IMC add-on board for economizer control is included with the economizer. MSAV equipped units require CO2 sensors.

Outdoor Air Damper

Mechanical, slide damper, 0 to 25% (fixed) outdoor air adjustable, installs in unit, outdoor air hood included.

21 Power Exhaust Fan(s) (10 And 20 Ton Models Only)

Installs external on 10 ton model, internal to 20 ton model, installed only with economizer option. Provides exhaust air pressure relief, interlocked to run when supply air blower is operating, fan runs when outdoor air dampers are 50% open (adjustable), motor is overload protected. 10-ton model includes steel cabinet and hood painted to match unit.

ROOF CURBS

Field Installed

Nailer strip furnished, mates to unit, US National Roofing Contractors Approved, shipped knocked down.

Corners fasten together with furnished hardware.

OPTIONS / ACCESSORIES

Item		Catalog No.	036	060	120	240
COOLING SYSTEM						
Corrosion Protection	Condenser Section	Factory	<input type="radio"/>	<input type="radio"/>	<input type="radio"/>	<input type="radio"/>
	Evaporator Section	Factory	<input type="radio"/>	<input type="radio"/>	<input type="radio"/>	<input type="radio"/>
	Both Sections	Factory	<input type="radio"/>	<input type="radio"/>	<input type="radio"/>	<input type="radio"/>
HEATING SYSTEM						
Gas Heat Input	High One-Stage - 75 kBtuh input		<input type="radio"/>			
	High Two-Stage - 81/125 kBtuh input			<input type="radio"/>		
	Standard Two-Stage - 84.5/130 kBtuh input				<input type="radio"/>	
	Medium Two-Stage - 117/180 kBtuh input				<input type="radio"/>	
	High Two-Stage - 156/240 kBtuh input				<input type="radio"/>	
	Standard Two-Stage - 169/260 kBtuh input					<input type="radio"/>
	Medium Two-Stage - 234/360 kBtuh input					<input type="radio"/>
	High Two-Stage - 312/480 kBtuh input					<input type="radio"/>
Gas Type	Natural Gas	Factory	<input type="radio"/>	<input type="radio"/>	<input type="radio"/>	<input type="radio"/>
	LPG/Propane Gas	Factory	<input type="radio"/>	<input type="radio"/>	<input type="radio"/>	<input type="radio"/>
Stainless Steel Heat Exchanger		Factory	<input type="radio"/>	<input type="radio"/>	<input type="radio"/>	<input type="radio"/>
BLOWER - SUPPLY AIR						
Constant Air Volume	1.5 hp	Factory	<input type="radio"/>	<input type="radio"/>		
	3 hp	Factory			<input type="radio"/>	
	5 hp	Factory				<input type="radio"/>
Multi-Stage Air Volume (MSAV)	3 hp	Factory			<input type="radio"/>	
	5 hp	Factory				<input type="radio"/>

NOTE - The catalog and model numbers that appear here are for ordering field installed accessories only.

⊗ - Field Installed or Configure to Order (factory installed)

○ - Configure to Order (Factory Installed)

X - Field Installed.

OPTIONS / ACCESSORIES

Item		Catalog No.	036	060	120	240
CONTROLS						
Commercial Controls						
CPC 810-3062	C0CTRL32131L	29W82	⊗	⊗	⊗	⊗
Danfoss RTC Control	C0CTRL38131L	29W81	⊗	⊗	⊗	⊗
Novar 2024	C0CTRL36131L	29W79	⊗	⊗	⊗	⊗
Novar 2024 For use with Economizer	C0CTRL37131L	29W80	⊗	⊗	⊗	⊗
Fresh Air Tempering	C0SNDC03AE1-	45L78	x	x	x	x
Smoke Detector	Supply	Factory	○	○	○	○
	Return	Factory	○	○	○	○
Unit Controller PC Software	C0SOFT01AE1-	96L80	x	x	x	x
PC Connection Kit	C0MISC47AE1-	96L78	x	x	x	x
Ethernet Converter Kit	C0MISC43AE1L	76M77	x	x	x	x
Network Modem Kit	C0MISC46AE1-	94L62	x	x	x	x
ELECTRICAL						
Voltage 60 hz	208/230V - 3 phase	Factory	○	○	○	○
	460V - 3 phase	Factory	○	○	○	○
	575V - 3 phase	Factory	○	○	○	○
INDOOR AIR QUALITY						
Indoor Air Quality (CO₂) Sensors						
Sensor - white case CO ₂ display	C0SNSR50AE1L	77N39	x	x	x	x
Sensor - white case no display	C0SNSR52AE1L	87N53	x	x	x	x
Sensor - black case CO ₂ display	C0SNSR51AE1L	87N52	x	x	x	x
Sensor - duct mount, black case, no display	C0SNSR53AE1L	87N54	x	x	x	x
CO ₂ Sensor Duct Mounting Kit	C0MISC19AE1-	85L43	x	x	x	x
Aspiration Box for duct mounting	C0MISC16AE1-	90N43	x	x	x	x
ECONOMIZER						
Economizer with Hood and Barometric Relief Damper (Global Sensor, field provided)		Factory	○	○	○	○
OUTDOOR AIR						
Manual Outdoor Air Damper with Hood		Factory	○	○	○	○
POWER EXHAUST						
Standard Static		Factory			○	○
ROOF CURBS - DOWN-FLOW						
14 in. height	S7CURB10101-	30W03	x	x		
	S1CURB10111-	30W06			x	
	LARMF18/36-14	16K87				x
24 in. height	S7CURB11101-	30W04	x	x		
	S1CURB11111-	30W07			x	
	LARMF18/36-24	16K88				x
LTL PACKAGING						
		Factory	○	○	○	○

NOTE - The catalog and model numbers that appear here are for ordering field installed accessories only.

○ - Configure to Order (Factory Installed)

x - Field Installed.

SEQUENCE OF OPERATION

THERMOSTAT MODE

The thermostat mode has specific sequence-of-operation scenarios for Lennox' SG and SC product line. The standard thermostat mode will typically allow up to 2 stages of heating and cooling operation. Units with a globally-controlled economizer option can have up to 2 stages of mechanical cooling and a free cooling economizer operation. If using the multi-stage air volume blower option, this mode will also allow up to 5 different supply fan speeds: 2 speeds for cooling mode, 1 speed for heating mode, 1 speed for ventilation, and an extra speed for when one of the smoke alarm options is used. When using the factory default, the smoke alarm mode will turn off the blower. It is important to note that the Integrated Modular Controller (IMC) merely passes along the instructions to provide heating, cooling, or other unit operations.

Thermostat Mode Heating

On units with two stages of heating, the unit's Integrated Modular Controller (IMC) will provide partial heating capacity after receiving the first heating demand from a thermostat or third-party unit controller. If the unit cannot satisfy the building's heating demand and the thermostat or third-party unit controller sends a second demand for heating, the unit will then activate the remainder of the gas heat exchanger or electric heating elements to provide full heating capacity. Remember that in this scenario the Integrated Modular Controller will instruct the unit to provide heating only after it receives a demand from the thermostat or third-party unit controller. The Integrated Modular Controller does not determine when to stage the unit's heat on and off, it simply responds to the commands it receives and relays these to the different components located within the unit.

Thermostat Mode CAV Cooling Without An Economizer

Upon receiving the first demand for cooling from a thermostat or third-party unit controller, the unit's Integrated Modular Controller will activate the first stage of cooling and bring the unit to partial cooling capacity. For example, in units with two refrigeration circuits, this will activate one of the circuits. Units with one refrigeration circuit will activate that circuit and be at full cooling capacity. For units with four refrigeration circuits, this will activate two of the circuits. If the thermostat or third-party unit controller sends a second demand for cooling, the Integrated Modular Controller will activate the remaining refrigeration circuits to bring the unit to full cooling capacity. Once the unit satisfies the cooling demand and the thermostat or third-party unit controller removes the cooling demands, the unit will stop all cooling operation.

Thermostat Mode CAV Cooling With Economizer

If the unit is controlled by a standard 2 stage cooling and 2 stage heating thermostat, it features an economizer, and outdoor air is suitable for free cooling, then a first call for cooling will cause the Integrated Modular Controller to open the economizer and modulate the damper position to maintain the supply air temperature at 55°F. This 55°F setpoint is adjustable, if needed. The unit will try to satisfy the cooling demand using outdoor air rather than mechanical cooling.

If mechanical cooling is locked out because of low ambient outside air temperature, then mechanical cooling will not come on and the unit will attempt to satisfy any demand by modulating the economizer's damper position to maintain a supply air temperature of 55°F. This sequence of operations is the same for units using standard thermostats or third-party unit controllers. The setpoints at which mechanical cooling locks out and the economizer maintains supply air temperature are adjustable.

If mechanical cooling is not locked out, the unit is unable to satisfy the call for cooling using the economizer, and the thermostat sends a second call for cooling, the unit's Integrated Modular Controller will bring on partial mechanical cooling for units with multiple refrigeration circuits or full mechanical cooling if the unit only has one refrigeration circuit. The economizer will also open to 100% during a second call for cooling. For example, if a 20 ton unit has been unable to cool the occupied space using the economizer and receives a second cooling demand from a thermostat, the economizer will open to 100% and the Integrated Modular Controller will instruct the unit to turn on two refrigeration circuits and provide 50% mechanical cooling capacity in an attempt to satisfy the building's cooling comfort needs. As long as the outside air is suitable, the unit will attempt to satisfy the cooling demand with the full open economizer and partial cooling until the demand is lifted. The unit will not increase the mechanical cooling capacity as long as the outside air is suitable for free cooling. The unit can however be set to bring on all mechanical cooling instead of partial after the second cooling call. Refer to the IMC manual for adjusting this parameter.

If the unit is controlled by a third-party unit controller and uses the global economizer input, then the operation varies slightly. A third-party unit controller will have a free cooling call signal in addition to the two cooling calls. A call for free cooling will cause the IMC to open the economizer and modulate the damper position to maintain the supply air temperature at 55°F. Again, this 55°F setpoint is adjustable, if needed. The unit will try to satisfy the cooling demand using outdoor air rather than mechanical cooling.

SEQUENCE OF OPERATION

THERMOSTAT MODE - CONTINUED

Thermostat Mode CAV Cooling With Economizer - Continued

If mechanical cooling is not locked out, the unit is unable to satisfy the call for cooling using the economizer, and the third-party unit controller sends a first call for cooling, the unit's Integrated Modular Controller will bring on the first stage of mechanical cooling. The economizer will also open to 100% during a first call for cooling. If the unit receives a second cooling demand, the economizer will remain fully open and the unit will bring on the remaining cooling refrigeration circuits, bringing the unit to full capacity.

If outdoor air is not suitable for free cooling then the unit will follow a different sequence of operation. This sequence of operations is the same for standard thermostats and third-party unit controllers. Essentially the unit's operation will mirror that of a unit without an economizer. A first cooling demand will cause the unit to activate partial cooling capacity while a second cooling demand will cause the unit to activate full cooling capacity. The biggest difference in this scenario is not the staging control, but the fact that the economizer will remain open at a specified minimum position when an occupied signal is supplied. This occurs to help ensure the building will receive the appropriate minimum amount of fresh outdoor air to meet the indoor air quality requirements.

Thermostat Mode MSAV Cooling Without An Economizer

Upon receiving the first call for cooling, the Integrated Modular Controller will activate partial cooling capacity, just like in a standard constant air volume unit. However, with a multi-stage air volume unit, the Integrated Modular Controller will also stage the supply fan to deliver a reduced volume of air to the space. For example, the supply fan speed setting for first stage cooling is set at 55% of maximum RPM. The user can change this setting in the Integrated Modular Controller.

Upon receiving a second cooling demand, the Integrated Modular Controller will activate the remaining refrigeration circuits to achieve full cooling capacity and bring the supply fan to 79% of maximum RPM, increasing the supply air volume. This setting is user-defined, and can be increased up to 100% of the fan's maximum speed. As you can see from this example, the speed of the supply fan fluctuates in response to the number of cooling demands the unit receives. If the space requires full cooling capacity, the supply fan will operate at a higher speed than if the space only requires partial cooling.

For more information regarding percentage of maximum RPM conversions, please see the table below. Note that this table uses an arbitrary static pressure.

PERCENTAGE OF MAXIMUM RPM EXAMPLES (10 Ton Units)

VFD Frequency HZ	% of Full RPM	RPM	CFM	Static in. w.g.
20	33	298	N/A	N/A
25	42	373	N/A	N/A
30	50	448	N/A	N/A
35	58	522	N/A	N/A
40	67	597	2290	0.31
45	75	671	2710	0.39
50	83	746	3160	0.49
55	92	821	3600	0.59
60	100	895	4100	0.70

SEQUENCE OF OPERATION

THERMOSTAT MODE - CONTINUED

Thermostat Mode MSAV Cooling With An Economizer

If the unit is controlled by a standard thermostat and it features multi-stage air volume, an economizer, and outdoor air is suitable for free cooling, a call for cooling will cause the Integrated Modular Controller to activate the economizer. The unit will try to satisfy the cooling demand using outdoor air rather than mechanical cooling by modulating the economizer damper to maintain a supply air temperature of 55°F. Since the unit features a multi-stage air volume supply fan, a call for free cooling will result in the fan running at the first stage cooling fan speed.

If mechanical cooling is locked out because of low ambient outside air temperature, then mechanical cooling will not come on and the unit will attempt to satisfy any cooling demand by modulating the economizer's damper position to maintain a supply air temperature of 55°F. This sequence of operations is the same for units using standard thermostats and third-party unit controllers. The setpoints at which mechanical cooling locks out and the economizer maintains supply air temperature are adjustable.

If mechanical cooling is not locked out, the unit is unable to satisfy the call for cooling, and the thermostat sends a second cooling demand, the unit's Integrated Modular Controller will activate partial mechanical cooling and open the economizer to 100%. The supply fan will remain at the first stage cooling fan speed. The unit will run at partial cooling and first stage cooling airflow until the demand is met, or the air becomes unsuitable for free cooling.

If the unit is controlled by a third-party unit controller, and it features multi-stage air volume, an economizer, and outdoor air is suitable for free cooling, a call for free cooling via the global input will cause the Integrated Modular Controller to turn on the supply fan and activate the economizer. The unit will try to satisfy the cooling demand using outdoor air rather than mechanical cooling by modulating the economizer damper to maintain a supply air temperature of 55°F. With a multi-stage air volume supply fan, a call for free cooling will result in the fan running at the first stage cooling fan speed.

If mechanical cooling is not locked out, the unit is unable to satisfy the call for cooling with economizer free cooling, and the third-party unit controller calls for cooling, the unit's Integrated Modular Controller will activate the first cooling stage to achieve partial mechanical cooling and open the economizer to 100%. The supply fan will remain in the first stage cooling speed. If this demand is not satisfied, the third-party unit controller will issue a second cooling demand to turn on the remainder of the refrigeration circuits bringing the unit to full capacity. At this point, the IMC will bring the supply fan to the second stage cooling speed.

If outdoor air is not suitable for free cooling then the unit will perform a different sequence of operation. Essentially the unit's operation will mirror that of a multi-stage air volume unit without an economizer. A first cooling demand will cause the unit to activate partial cooling capacity with a reduced fan speed while a second cooling demand will cause the unit to activate full cooling capacity with second stage cooling speed. This sequence of operations is the same for units using standard thermostats and third-party unit controllers.

It is important to note that MSAV units with an economizer must have a CO₂ sensor to know how much to ventilate. The CO₂ level will take precedence over the economizer minimum damper position to assure that the required levels of ventilation are always met.

For more information regarding percentage of maximum RPM conversions, please see the table below. Note that this table uses an arbitrary static pressure.

PERCENTAGE OF MAXIMUM RPM EXAMPLES (20 Ton Units)

VFD Frequency HZ	% of Full RPM	RPM	CFM	Static in. w.g.
20	33	257	N/A	N/A
25	42	321	N/A	N/A
30	50	385	N/A	N/A
35	58	449	4375	0.34
40	67	513	4800	0.44
45	75	577	5600	0.56
50	83	642	6280	0.70
55	92	706	7200	0.84
60	100	770	8000	1.00

SEQUENCE OF OPERATION

ZONE SENSOR MODE

When in zone sensor mode, the SG and SC unit can increase cooling or heating operation up to 4 stages. In this case, the Integrated Modular Controller will control all unit staging operations. While in zone sensor mode, multi stage air volume applications can use up to 4 different supply fan speeds for cooling. As you can see, zone sensor mode takes full advantage of the IMC's features, increasing staging and control capabilities. To operate correctly, the unit must receive information from a temperature sensor and setpoint information from a network device. Based on this information, the Integrated Modular Controller will either turn on or off various cooling and heating stages to maintain comfort control.

In zone sensor mode, it is possible to operate the unit without a network device. In this case the IMC will control the zone temperature based on the backup occupied and unoccupied setpoints stored in the IMC. The IMC decides which setpoints to use based on the status of the occupied input. For example, if the occupied input is energized, the IMC will use the occupied backup setpoints and if the occupied input is not energized the IMC will use the unoccupied backup setpoints. It is important to note that all units arrive from the factory jumpered to energize the occupied input.

In this scenario the IMC not only records diagnostic information and makes sure the unit maintains safe operation limits, it also controls all staging and unit operations.

Zone Sensor Mode Heating

For heating, the Integrated Modular Controller monitors space temperature from the zone sensor. Based on this information and the setpoints sent to the IMC from the Lennox or third-party network device, the Integrated Modular Controller turns on or off the heating stages to maintain the desired temperature setpoint.

The SG and SC product line features up to four independent heat stages in larger equipment. The exact percent of heating capacity used will vary depending on the type of unit, whether it is gas or electric heating, the size of the unit and the size of the heating capacity. Regardless of how many stages are present, the Integrated Modular Controller will seek to provide just the right amount of heat to satisfy the demand.

The sequence of operation for increasing and decreasing heating stages is best shown by the staging chart on page 13. As you can see from the chart, the unit will activate the heating stages if the space temperature drops to certain temperatures. If the temperature continues to drop, the unit will continue to add heating stages until the unit reaches full heating capacity. Notice that the example heating setpoint is 70°F with a 1° dead band. Also notice that the stage-up timer is 15 minutes. The IMC will call for the next heating stage if the space temperature has been in the stage-up timer dead band region for 15 continuous minutes. The stage-up timer dead band region is the range between the temperature at which the current heating stage was called, and the temperature at which the next heating stage would be called. Heating stages will deactivate immediately after the space temperature has been satisfied. These are all default setpoints and can be changed to customize the unit to the specific application.

To see how these features work, let's assume the temperature in the space has just dropped to 69.4 degrees, outside of the heating dead band set between 69.5°F and 70.5°F. The zone sensor will relay the space temperature to the Integrated Modular Controller, which will then instruct the unit to start the first stage heating operation to return the space back to the desired setpoint of 70°F. Notice that the space temperature must reach the top portion of the heating dead band, 70.5°F, before heating will actually cease.

If the space temperature stays between 69°F and 69.5°F for 15 continuous minutes, then the second heating stage will be started. This illustrates the use of the stage-up timer.

It is important to note that units with multi-stage air volume supply fans operate at the selected heating speed for all stages of heating. The supply fan speed will not change as heat stages increase or decrease because there is only one heating supply fan speed setpoint.

SEQUENCE OF OPERATION

ZONE SENSOR MODE - CONTINUED

ZONE SENSOR STAGES FOR GAS / ELECTRIC UNITS Default Values Shown

Units With Economizer:

C1=Free Cooling

C2=Compressor 1

C3=Compressor 2

C4=Compressor 3 + 4

C1=Cooling Stage 1

C2=Cooling Stage 2

C3=Cooling Stage 3

C4=Cooling Stage 4

H1=Heating Stage 1

H2=Heating Stage 2

H3=Heating Stage 3

H4=Heating Stage 4

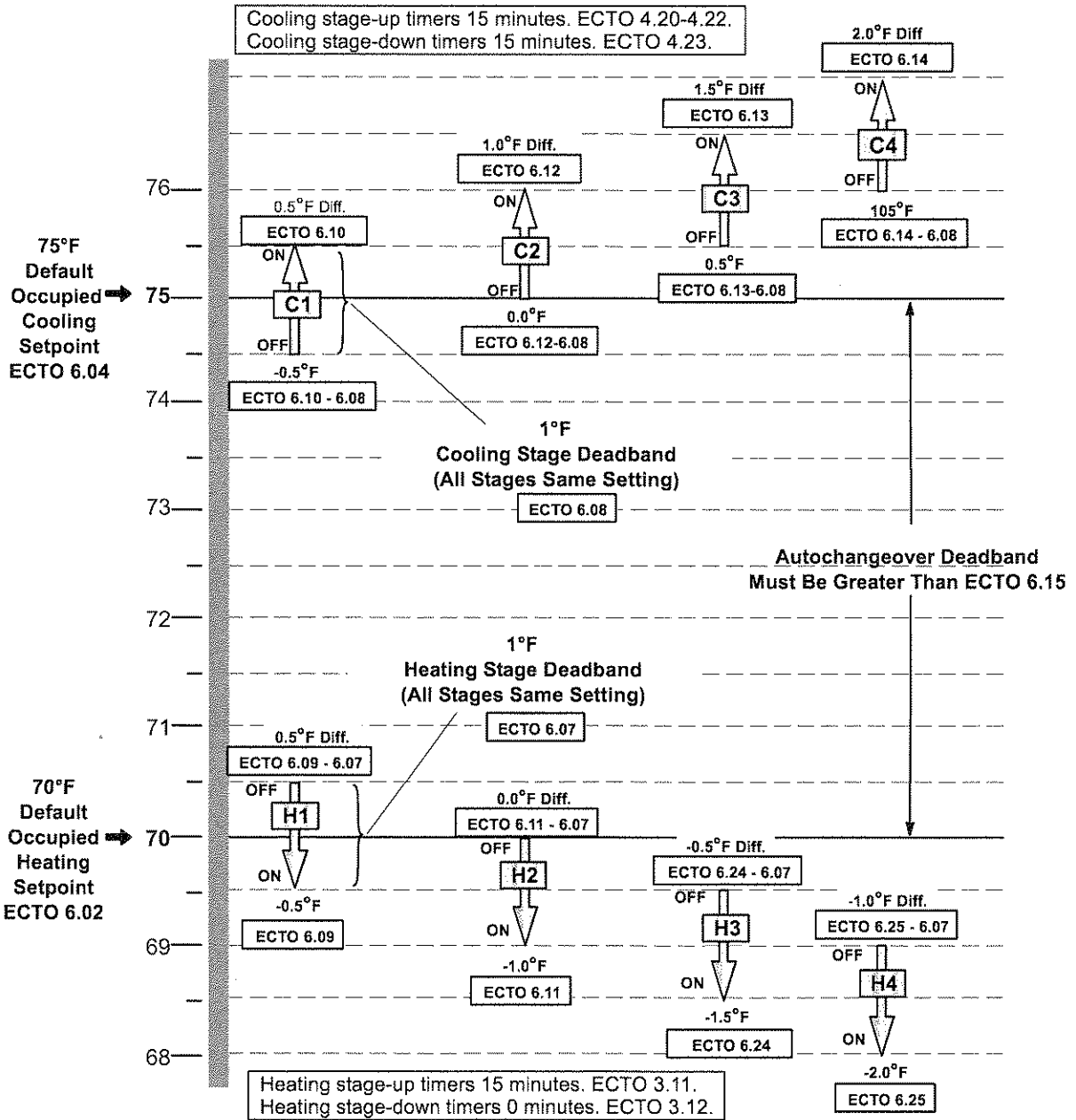

SEQUENCE OF OPERATION

ZONE SENSOR MODE - CONTINUED

Zone Sensor Mode Cooling

For cooling, the Integrated Modular Controller monitors space temperature from the zone sensor. Based on this information and the setpoints sent to the IMC from the Lennox or third-party network device, the Integrated Modular Controller turns on or off cooling stages to maintain the desired temperature setpoint.

The SG product line features up to four independent cooling stages in larger equipment. Regardless of how many stages are available, the Integrated Modular Controller will seek to provide just the right amount of cooling to satisfy the demand. This helps provide great comfort control and can minimize energy consumption.

The sequence of operation for increasing and decreasing cooling stages is best shown by the staging chart on page 13. As you can see from the chart, the unit will activate cooling stages if the space temperature rises above certain temperatures. If the temperature continues to rise, the unit will continue to add cooling stages until the unit reaches full cooling capacity. Notice that the example cooling setpoint is 75°F with a 1° dead band. Notice that the stage-up timer is 15 minutes. The IMC will call for the next cooling stage if the space temperature has been in the stage-up timer dead band region for 15 continuous minutes. The stage-up timer dead band region is the range between the temperature at which the current cooling stage was called, and the temperature at which the next cooling stage would be called. Cooling mode has a stage-down delay default of 15 minutes. This feature is to make sure the unit doesn't prematurely shut off a cooling stage. These are all default setpoints and can be changed to customize the unit to the specific application.

To see how these features work, let's assume the temperature in the space has just risen to 75.6°F, outside of the cooling dead band set between 75.5°F and 74.5°F. The zone sensor will relay the space temperature to the Integrated Modular Controller, which will then instruct the unit to start the first stage cooling operation to return the space back to the desired setpoint of 75°F. Notice that the space temperature must reach the bottom portion of the cooling dead band, 74.5°F, before cooling will actually cease. If the space temperature stays between 75.5° and 76° degrees for 15 continuous minutes, then the second cooling stage will be started. This illustrates the use of the stage-up timer.

Zone Sensor Mode Cooling CAV With/Without Economizer

If the outdoor air is suitable and the unit features an economizer, instead of using mechanical cooling to meet the first cooling demand, the Integrated Modular controller will try to meet the demand by opening the economizer and using outdoor air. The economizer damper will modulate to maintain a supply air temperature of 55°F to meet the cooling demand.

If mechanical cooling is locked out because of low ambient outside air temperature, then mechanical cooling will not come on and the unit will attempt to satisfy any demand by modulating the economizer's damper position to maintain a supply air temperature of 55°F. The setpoints at which mechanical cooling locks out and the economizer maintains supply air temperature are adjustable.

If mechanical cooling is not locked out and if the unit is able to satisfy the room temperature requirements using outdoor air, then the unit will close the economizer to the minimum setpoint and cease cooling operation. If the unit is unable to satisfy the room temperature requirements using outdoor air, then the unit will react to a second cooling demand, which will trigger the first stage of mechanical cooling and bring the economizer to the full open position. The unit will continue turning on stages of mechanical cooling until the unit has satisfied the space temperature setpoint.

Because the unit can provide up to 4 stages of cooling, and the economizer now qualifies as the first stage of cooling, the Integrated Modular Controller will group the third and fourth compressors in a four compressor unit together. This means that to address the fourth stage cooling demand the unit will increase the mechanical cooling from 50 to 100%. See chart for unit operation without an economizer.

Cooling Demand	Unit with Economizer	Unit without Economizer or Outdoor Air is Unsuitable
One	Economizer	Compressor #1
Two	Economizer + Compressor #1	Compressor #1, 2
Three	Economizer + Compressor #1, 2	Compressor #1, 2, 3
Four	Economizer + All Compressors	All Compressors

SEQUENCE OF OPERATION

ZONE SENSOR MODE - CONTINUED

Zone Sensor Mode MSAV Without An Economizer

In this scenario, the cooling staging works exactly the same way as a unit with constant volume configuration, except that each time the Integrated Modular Controller activates or deactivates cooling stages, the supply fan also changes speeds. The change is best illustrated by an example. The fan speeds used in the example are selectable. We will look at the operation of a 20 ton unit.

Upon determining a cooling demand, the unit will stage on the supply fan to run at 35% of maximum RPM. Moving to second stage cooling will increase the supply fan speed to 45% of maximum RPM. Adding a third stage of cooling will further increase the supply fan speed to 60% of maximum RPM while adding the fourth and final stage of cooling will put the supply fan at 73% of maximum RPM. This setting is user defined, and can be increased up to 100% of the fan's maximum RPM.

Cooling Demand	Cooling Operation	Supply Fan Speed (% of Maximum RPM)
One	Compressor #1	35%
Two	Compressor #1, 2	45%
Three	Compressor #1, 2, 3	60%
Four	All Compressors	73%

NOTE - 20-Ton MSAV Operation

Zone Sensor Mode MSAV With An Economizer

Adding an economizer to multi-stage air volume operation does not change the supply fan speed staging operation, it simply changes what method the unit will use to cool the space. The cooling stages will act exactly like the constant air volume units. However, the supply fan will change speeds depending on which cooling stage the unit is in. For example, if outdoor air is suitable, the first cooling demand will cause the unit to modulate the economizer damper to maintain a supply air temperature of 55°F. If the unit is a 20-ton model, during this free cooling operation the supply fan will operate at the first stage cooling speed, which in this case is 35% of the fans maximum RPM. As the unit increases stages of cooling, the supply fan will increase along with the cooling stages. Upon receiving a second cooling demand, the unit will activate one refrigeration circuit, and keep the supply fan at 35% speed. Moving to third stage cooling will increase the supply fan speed to 45% and add another refrigeration circuit. Adding another stage of cooling will further increase the supply fan speed to 73% and add the final two refrigeration circuits. Reference the chart below to see the differences between multi-stage air volume units with and without an economizer.

Cooling Demand	Unit with Economizer		Unit without Economizer or Outdoor Air is Unsuitable	
	Cooling Operation	Supply Fan Speed	Cooling Operation	Supply Fan Speed
One	Economizer	35%	Compressor #1	35%
Two	Economizer + Compressor #1	35%	Compressor #1, 2	45%
Three	Economizer + Compressor #1, 2	45%	Compressor #1, 2, 3	60%
Four	Economizer + All Compressors	73%	All Compressors	73%

NOTE - 20-Ton MSAV Operation

SPECIFICATIONS
3 AND 5 TON

General Data		Nominal Tonnage	3 Ton	5 Ton
		Model No.	SGA036H4	SGA060H4
		Efficiency Type	High	High
Cooling Performance	Gross Cooling Capacity - Btuh		37,200	61,500
	¹ Net Cooling Capacity - Btuh		36,000	59,500
	ARI Rated Air Flow - cfm		1200	1650
	Total Unit Power		2.5	4.65
	¹ SEER (Btuh/Watt)		16.1	15.5
	¹ EER (Btuh/Watt)		14.3	12.8
Refrigerant Charge Furnished (R-410A)			16 lbs. 8 oz.	18 lbs. 8 oz.
² Sound Rating Number (dB)			76	78
Gas Heating Options Available - See below			High (1 Stage)	High (2 Stage)
Compressor Type (No.)			Scroll (1)	Scroll (1)
Condenser Coil	Net face area - sq. ft.		19	19
	Tube diameter - in.		3/8	3/8
	Number of rows		3	3
	Fins per inch		14	14
Condenser Fan(s)	Motor horsepower		(1) 1/10	(2) 1/10
	Motor rpm		825	825
	Total Motor watts		160	320
	Diameter - in.		(1) 24	(2) 24
	Number of blades		3	3
	Total air volume - cfm		2800	4900
Evaporator Coil	Net face area - sq. ft.		8.0	8.0
	Tube diameter - in.		3/8	3/8
	Number of rows		4	4
	Fins per inch		14	14
	Drain connection - no. & size		(1) 1	(1) 1
Expansion device type			Thermostatic Expansion Valve	
³ Indoor Blower	Nominal motor output		1.5	1.5
	Maximum usable motor output		1.7	1.7
	RPM Range		575 - 1130 rpm	850 - 1320 rpm
	Wheel nominal diameter x width - in.		(1) 10 x 10	(1) 10 x 10
Filters	Type of filter		MERV 7 or equivalent	
	Number and size - in.		(4) 16 x 20 x 2	(4) 16 x 20 x 2
Electrical characteristics			208/230V, 460V, or 575V - 60 hertz - 3 phase	

NOTE - Net capacity includes evaporator blower motor heat deduction. Gross capacity does not include evaporator blower motor heat deduction.

¹ Certified in accordance with the ULE certification program, which is based on ARI Standard 340/360, 95° F outdoor air temperature and 80° F db/67° F wb entering evaporator air; minimum external duct static pressure.

² Sound Rating Number rated in accordance with test conditions included in ARI Standard 270.

³ Using total air volume and system static pressure requirements determine from blower performance tables rpm and motor output required. Maximum usable output of motors furnished are shown. In Canada, nominal motor output is also maximum usable motor output. If motors of comparable output are used, be sure to keep within the service factor limitations outlined on the motor nameplate.

SPECIFICATIONS - GAS HEAT
3 AND 5 TON

Heat Input Type		High - 1 Stage	High - 2 Stage
Gas Input - Btuh Natural Gas	First Stage	---	81,000
	Second Stage	75,000	125,000
	Second Stage Output	60,000	100,000
Gas Input - Btuh LPG/Propane	First Stage	---	90,000
	Second Stage	75,000	125,000
	Second Stage Output	60,000	100,000
Recommended Gas Supply Pressure - Natural		7.0 in. w.g.	
LPG/Propane		11.0 in. w.g.	
CSA Thermal Efficiency		80%	
Gas Supply Connections		3/4 in. npt	

SPECIFICATIONS

10 TON

General Data	Nominal Tonnage Model No.	10 Ton SGA120H4B	10 Ton SGA120H4M
	Efficiency Type	High	High
Cooling Performance	Gross Cooling Capacity - Btuh	123,000	123,000
	¹ Net Cooling Capacity - Btuh	119,000	119,000
	ARI Rated Air Flow - cfm	3700	3700
	Total Unit Power	9.7	9.8
	¹ EER (Btuh/Watt)	12.3	12.1
	² Integrated Part Load Value (Btuh/Watt)	13.2	15.0
Refrigerant Charge Furnished R-410A	Circuit 1	22 lbs. 8 oz.	24 lbs. 0 oz.
	Circuit 2	21 lbs. 0 oz.	21 lbs. 8 oz.
³ Sound Rating Number (dB)		88	88
Gas Heating Options Available - See below		Standard (2 Stage), Medium (2 Stage), or High (2 Stage)	
Compressor Type (No.)		Scroll (2)	Scroll (2)
Condenser Coil	Net face area - sq. ft.	47.1	47.1
	Tube diameter - in.	3/8	3/8
	Number of rows	3	3
	Fins per inch	14	14
Condenser Fan(s)	Motor horsepower	(3) 1/3	(3) 1/3
	Motor rpm	1075	1075
	Total Motor watts	940	940
	Diameter - in.	(3) 24	(3) 24
	Number of blades	3	3
	Total air volume - cfm	11,800	11,800
Evaporator Coil	Net face area - sq. ft.	15.6	15.6
	Tube diameter - in.	3/8	3/8
	Number of rows	4	4
	Fins per inch	14	14
	Drain connection - no. & size	(1) 1	(1) 1
	Expansion device type	Thermostatic Expansion Valve	
⁴ Indoor Blower	Nominal motor output	3	3
	Maximum usable motor output	3.45	3.45
	RPM Range	650 - 920 rpm	298 - 895 rpm
	Wheel nominal diameter x width - in.	(1) 15 x 15	(1) 15 x 15
Filters	Type of filter	MERV 7 or equivalent	
	Number and size - in.	(6) 16 x 25 x 2	
Electrical characteristics		208/230V, 460V, or 575V - 60 hertz - 3 phase	

NOTE - Net capacity includes evaporator blower motor heat deduction. Gross capacity does not include evaporator blower motor heat deduction.

¹ Certified in accordance with the ULE certification program, which is based on ARI Standard 340/360, 95°F outdoor air temperature and 80°F db/67°F wb entering evaporator air; minimum external duct static pressure.

² Integrated Part Load Value rated at 80°F outdoor air temperature.

³ Sound Rating Number rated in accordance with test conditions included in ARI Standard 270.

⁴ Using total air volume and system static pressure requirements determine from blower performance tables rpm and motor output required. Maximum usable output of motors furnished are shown. In Canada, nominal motor output is also maximum usable motor output. If motors of comparable output are used, be sure to keep within the service factor limitations outlined on the motor nameplate.

SPECIFICATIONS - GAS HEAT

10 TON

Heat Input Type		Standard - 2 Stage	Medium - 2 Stage	High - 2 Stage
Gas Input - Btuh Natural Gas	First Stage	84,500	117,000	156,000
	Second Stage	130,000	180,000	240,000
	Second Stage Output	104,000	144,000	192,000
Gas Input - Btuh LPG/Propane	First Stage	94,000	130,000	173,000
	Second Stage	130,000	180,000	240,000
	Second Stage Output	104,000	144,000	192,000
Recommended Gas Supply Pressure - Natural		7.0 in. w.g.		
LPG/Propane		11.0 in. w.g.		
CSA Thermal Efficiency		80%		
Gas Supply Connections		3/4 in. npt		

SPECIFICATIONS

20 TON

General Data	Nominal Tonnage	20 Ton	20 Ton
	Model No.	SGA240H4B	SGA240H4M
	Efficiency Type	High	High
Cooling Performance	Gross Cooling Capacity - Btuh	242,000	242,000
	¹ Net Cooling Capacity - Btuh	236,000	236,000
	ARI Rated Air Flow - cfm	6500	6500
	Total Unit Power	18.7	18.7
	¹ EER (Btuh/Watt)	12.6	12.6
	² Integrated Part Load Value (Btuh/Watt)	14.4	16.2
Refrigerant Charge Furnished R-410A	Circuit 1	17 lbs. 0 oz.	16 lbs. 0 oz.
	Circuit 2	17 lbs. 0 oz.	16 lbs. 0 oz.
	Circuit 3	17 lbs. 0 oz.	15 lbs. 0 oz.
	Circuit 4	17 lbs. 0 oz.	15 lbs. 0 oz.
³ Sound Rating Number (dB)		92	92
Gas Heating Options Available - See below		Standard (2 Stage), Medium (2 Stage), or High (2 Stage)	
Compressor Type (No.)		Scroll (4)	Scroll (4)
Condenser Coil	Net face area - sq. ft.	70.6	70.6
	Tube diameter - in.	3/8	3/8
	Number of rows	3	3
	Fins per inch	14	14
Condenser Fan(s)	Motor horsepower	(6) 1/3	(6) 1/3
	Motor rpm	1075	1075
	Total Motor watts	1900	1900
	Diameter - in.	(6) 24	(6) 24
	Number of blades	3	3
	Total air volume - cfm	21,500	21,500
Evaporator Coil	Net face area - sq. ft.	33.3	33.3
	Tube diameter - in.	3/8	3/8
	Number of rows	3	3
	Fins per inch	14	14
	Drain connection - no. & size	(1) 1	(1) 1
	Expansion device type	Thermostatic Expansion Valve	
⁴ Indoor Blower	Nominal motor output	5	5
	Maximum usable motor output	5.75	5.75
	RPM Range	450 - 785 rpm	257 - 770 rpm
	Wheel nominal diameter x width - in.	(2) 18 x 15	(2) 18 x 15
Filters	Type of filter	MERV 7 or equivalent	
	Number and size - in.	(12) 20 x 20 x 2	
Electrical characteristics		208/230V, 460V, or 575V - 60 hertz - 3 phase	

NOTE - Net capacity includes evaporator blower motor heat deduction. Gross capacity does not include evaporator blower motor heat deduction.
¹ Certified in accordance with the ULE certification program, which is based on ARI Standard 340/360, 95°F outdoor air temperature and 80°F db/67°F wb entering evaporator air; minimum external duct static pressure.

² Integrated Part Load Value rated at 80°F outdoor air temperature.

³ Sound Rating Number rated in accordance with test conditions included in ARI Standard 270.

⁴ Using total air volume and system static pressure requirements determine from blower performance tables rpm and motor output required. Maximum usable output of motors furnished are shown. In Canada, nominal motor output is also maximum usable motor output. If motors of comparable output are used, be sure to keep within the service factor limitations outlined on the motor nameplate.

SPECIFICATIONS - GAS HEAT

20 TON

Heat Input Type		Standard - 2 Stage	Medium - 2 Stage	High - 2 Stage
Gas Input Btuh Nat.	First Stage	169,000	234,000	312,000
	Second Stage	260,000	360,000	480,000
	Second Stage Output	208,000	288,000	384,000
Gas Input - Btuh LPG/Propane	First Stage	187,000	259,000	346,000
	Second Stage	260,000	360,000	480,000
	Second Stage Output	208,000	288,000	384,000
Recommended Gas Supply Pressure - Natural		7.0 in. w.g.		
LPG/Propane		11.0 in. w.g.		
CSA Thermal Efficiency		80%		
Gas Supply Connections		1 in. npt		

SPECIFICATIONS - INTEGRATED MODULAR CONTROLLER (IMC)

Operating Environment	Temperature: -40°F to 155°F Humidity: 10% - 95% RH, Non- Condensing
Power Requirements	24VAC (+/-25%), 50/60Hz 4.8 VA for IMC maximum 14.4 VA for IMC w/all expansion boards Maximum
Memory Type	Re-programmable Flash
Device Commissioning	Auto-poll (real plug and play)
Unit type	Electric/Electric, Gas/Electric & Heat Pumps (Rooftops) , CAV and VAV units
Cooling stages	4
Heating stages	4
Modulating Gas Valves	2
Electronic Configure To Order Parameters	235
Alarm Codes	101
Alarm Codes Stored	84
Display Type	3 Digit Seven Segment Red LED
Indicator LEDs	1- Heartbeat on each board 1- Bus transmit 1 - Bus receive 1- each for Y1,Y2,W1,W2,G,OCP
Dimensions	IMC Main Board: Height: 1-1/2 in., Width: 12 in., Depth: 7 in. #2 Compressor Module, #2 Compressor and Reversing Valve Module #3 and 4 Compressor Module, #2 Electric Heat Module, #2 Gas Heat Module, Economizer Module, Humiditrol Module VAV, Modulating Gas and I/O Modules: Height: 7/8 in., Width: 3-3/4 in., Depth: 4 in.
Weight	2 lbs. for IMC w/all expansion boards installed
Cable Type	SysBus - Lennox yellow COMM cable: COMISC00AE1- (27M19) (500 ft. box), COMISC04AE1- (94L63) (1000 ft. box), COMISC01AE1- (68M25) (2500 ft. roll) ZoneBus - Lennox purple COMM cable: COMISC05AE1- (23W99) (500 ft. box) COMISC06AE1- (24W00) (1000 ft. box) COMISC07AE1- (24W01) (2500 ft. roll) Non-Communicating Zone Sensor Non-Communicating RH Sensor Non-Communicating CO2 Sensor

COOLING RATINGS

3 TON HIGH EFFICIENCY CAV - ONE COMPRESSOR OPERATING

SGA036H4B

Entering Wet Bulb Temperature	Total Air Volume		Outdoor Air Temperature Entering Outdoor Coil																							
			85°F (29°C)						95°F (35°C)						105°F (41°C)						115°F (46°C)					
			Total Cooling Capacity		Comp Motor kW Input	Sensible To Total Ratio (S/T) Dry Bulb			Total Cooling Capacity		Comp Motor kW Input	Sensible To Total Ratio (S/T) Dry Bulb			Total Cooling Capacity		Comp Motor kW Input	Sensible To Total Ratio (S/T) Dry Bulb			Total Cooling Capacity		Comp Motor kW Input	Sensible To Total Ratio (S/T) Dry Bulb		
			kBtuh	kW		75°F 24°C	80°F 27°C	85°F 29°C	kBtuh	kW		75°F 24°C	80°F 27°C	85°F 29°C	kBtuh	kW		75°F 24°C	80°F 27°C	85°F 29°C	kBtuh	kW		75°F 24°C	80°F 27°C	85°F 29°C
63°F (17°C)	960	455	35.4	10.4	1.77	.68	.84	1.00	33.7	9.9	2.01	.69	.87	1.00	31.8	9.3	2.29	.71	.90	1.00	29.8	8.7	2.62	.73	.94	1.00
	1200	565	36.9	10.8	1.78	.74	.94	1.00	35.2	10.3	2.02	.76	.97	1.00	33.3	9.8	2.30	.79	1.00	1.00	31.5	9.2	2.63	.83	1.00	1.00
	1440	680	38.4	11.3	1.78	.81	1.00	1.00	36.7	10.8	2.03	.84	1.00	1.00	35.0	10.3	2.31	.88	1.00	1.00	33.0	9.7	2.63	.92	1.00	1.00
67°F (19°C)	960	455	37.8	11.1	1.78	.53	.66	.79	36.0	10.6	2.03	.54	.67	.82	34.0	10.0	2.30	.55	.69	.86	31.9	9.3	2.63	.56	.71	.89
	1200	565	39.2	11.5	1.79	.57	.71	.90	37.2	10.9	2.03	.58	.74	.94	35.1	10.3	2.31	.59	.76	.98	32.8	9.6	2.63	.61	.80	1.00
	1440	680	40.1	11.8	1.79	.60	.79	1.00	38.1	11.2	2.04	.62	.82	1.00	35.9	10.5	2.32	.63	.85	1.00	33.6	9.8	2.64	.65	.89	1.00
71°F (22°C)	960	455	40.5	11.9	1.79	.40	.51	.63	38.5	11.3	2.04	.40	.52	.65	36.4	10.7	2.32	.40	.53	.66	34.1	10.0	2.64	.41	.55	.69
	1200	565	41.8	12.3	1.80	.41	.55	.69	39.7	11.6	2.05	.41	.56	.71	37.4	11.0	2.33	.42	.58	.74	35.0	10.3	2.65	.43	.60	.77
	1440	680	42.7	12.5	1.81	.42	.59	.76	40.5	11.9	2.06	.43	.61	.79	38.2	11.2	2.33	.44	.62	.83	35.7	10.5	2.65	.45	.64	.87

5 TON HIGH EFFICIENCY CAV - ONE COMPRESSOR OPERATING

SGA060H4B

Entering Wet Bulb Temperature	Total Air Volume		Outdoor Air Temperature Entering Outdoor Coil																							
			85°F (29°C)						95°F (35°C)						105°F (41°C)						115°F (46°C)					
			Total Cooling Capacity		Comp Motor kW Input	Sensible To Total Ratio (S/T) Dry Bulb			Total Cooling Capacity		Comp Motor kW Input	Sensible To Total Ratio (S/T) Dry Bulb			Total Cooling Capacity		Comp Motor kW Input	Sensible To Total Ratio (S/T) Dry Bulb			Total Cooling Capacity		Comp Motor kW Input	Sensible To Total Ratio (S/T) Dry Bulb		
			kBtuh	kW		75°F 24°C	80°F 27°C	85°F 29°C	kBtuh	kW		75°F 24°C	80°F 27°C	85°F 29°C	kBtuh	kW		75°F 24°C	80°F 27°C	85°F 29°C	kBtuh	kW		75°F 24°C	80°F 27°C	85°F 29°C
63°F (17°C)	1600	755	61.0	17.9	3.27	.67	.83	1.00	67.9	17.0	3.72	.68	.87	1.00	64.5	16.0	4.23	.70	.91	1.00	50.8	14.9	4.82	.73	.96	1.00
	2000	945	63.2	18.5	3.31	.72	.95	1.00	60.1	17.6	3.75	.75	.98	1.00	56.9	16.7	4.26	.79	1.00	1.00	53.5	15.7	4.86	.83	1.00	1.00
	2400	1135	65.7	19.3	3.34	.81	1.00	1.00	62.7	18.4	3.79	.84	1.00	1.00	59.3	17.4	4.30	.88	1.00	1.00	55.6	16.3	4.90	.93	1.00	1.00
67°F (19°C)	1600	755	64.7	19.0	3.32	.52	.65	.79	61.3	18.0	3.77	.53	.66	.83	57.8	16.9	4.28	.54	.68	.86	53.6	15.7	4.87	.56	.71	.91
	2000	945	66.6	19.5	3.35	.55	.71	.91	63.0	18.5	3.80	.57	.73	.95	59.2	17.3	4.31	.58	.76	.99	55.1	16.1	4.90	.60	.81	1.00
	2400	1135	68.0	19.9	3.38	.59	.78	1.00	64.4	18.9	3.82	.61	.82	1.00	60.5	17.7	4.33	.62	.86	1.00	56.3	16.5	4.92	.65	.91	1.00
71°F (22°C)	1600	755	68.8	20.2	3.39	.39	.50	.62	65.1	19.1	3.83	.39	.52	.64	61.2	17.9	4.34	.39	.53	.66	57.0	16.7	4.93	.40	.54	.69
	2000	945	70.6	20.7	3.42	.40	.54	.69	66.8	19.6	3.86	.40	.56	.71	62.7	18.4	4.37	.41	.57	.73	58.2	17.1	4.96	.42	.59	.78
	2400	1135	71.8	21.0	3.44	.41	.58	.76	67.9	19.9	3.88	.42	.60	.79	63.7	18.7	4.39	.43	.62	.84	59.1	17.3	4.98	.44	.64	.89

10 TON HIGH EFFICIENCY CAV - ONE COMPRESSOR OPERATING

SGA120H4B

Entering Wet Bulb Temperature	Total Air Volume		Outdoor Air Temperature Entering Outdoor Coil																							
			65°F (18°C)						75°F (24°C)						85°F (29°C)						95°F (35°C)					
			Total Cooling Capacity		Comp Motor kW Input	Sensible To Total Ratio (S/T) Dry Bulb			Total Cooling Capacity		Comp Motor kW Input	Sensible To Total Ratio (S/T) Dry Bulb			Total Cooling Capacity		Comp Motor kW Input	Sensible To Total Ratio (S/T) Dry Bulb			Total Cooling Capacity		Comp Motor kW Input	Sensible To Total Ratio (S/T) Dry Bulb		
			kBtuh	kW		75°F 24°C	80°F 27°C	85°F 29°C	kBtuh	kW		75°F 24°C	80°F 27°C	85°F 29°C	kBtuh	kW		75°F 24°C	80°F 27°C	85°F 29°C	kBtuh	kW		75°F 24°C	80°F 27°C	85°F 29°C
63°F (17°C)	3200	1510	67.4	19.8	2.30	.58	1.00	1.00	65.0	19.0	2.66	.59	1.00	1.00	62.4	18.3	3.05	.60	1.00	1.00	59.7	17.5	3.47	.62	1.00	1.00
	4000	1890	70.6	20.7	2.31	.63	1.00	1.00	67.9	19.9	2.68	.66	1.00	1.00	65.2	19.1	3.07	1.00	1.00	1.00	62.2	18.2	3.49	1.00	1.00	1.00
	4800	2265	72.9	21.4	2.32	1.00	1.00	1.00	70.1	20.5	2.69	1.00	1.00	1.00	67.1	19.7	3.08	1.00	1.00	1.00	64.0	18.8	3.51	1.00	1.00	1.00
67°F (19°C)	3200	1510	69.1	20.3	2.31	.44	.57	1.00	66.3	19.4	2.67	.46	.58	1.00	63.3	18.6	3.06	.46	.59	1.00	60.3	17.7	3.48	.47	.61	1.00
	4000	1890	71.0	20.8	2.32	.48	.62	1.00	68.1	20.0	2.68	.49	.63	1.00	65.2	19.1	3.07	.50	.63	1.00	62.2	18.2	3.49	.52	1.00	1.00
	4800	2265	72.9	21.4	2.33	.52	1.00	1.00	70.1	20.5	2.69	.53	1.00	1.00	67.2	19.7	3.08	.54	1.00	1.00	64.1	18.8	3.50	.56	1.00	1.00
71°F (22°C)	3200	1510	73.1	21.4	2.33	.30	.43	.55	70.0	20.5	2.69	.31	.44	.57	66.8	19.6	3.08	.31	.45	.58	63.3	18.6	3.50	.32	.47	.60
	4000	1890	74.3	21.8	2.33	.32	.48	.61	71.2	20.9	2.70	.33	.49	.62	67.9	19.9	3.09	.33	.50	.77	64.4	18.9	3.51	.34	.52	1.00
	4800	2265	75.3	22.1	2.34	.34	.52	.97	72.1	21.1	2.71	.34	.53	1.00	68.8	20.2	3.10	.35	.54	1.00	65.3	19.1	3.52	.36	.56	1.00

10 TON HIGH EFFICIENCY CAV - ALL COMPRESSORS OPERATING

SGA120H4B

Entering Wet Bulb Temperature	Total Air Volume		Outdoor Air Temperature Entering Outdoor Coil																							
			85°F (29°C)						95°F (35°C)						105°F (41°C)						115°F (46°C)					
			Total Cooling Capacity		Comp Motor kW Input	Sensible To Total Ratio (S/T) Dry Bulb			Total Cooling Capacity		Comp Motor kW Input	Sensible To Total Ratio (S/T) Dry Bulb			Total Cooling Capacity		Comp Motor kW Input	Sensible To Total Ratio (S/T) Dry Bulb			Total Cooling Capacity		Comp Motor kW Input	Sensible To Total Ratio (S/T) Dry Bulb		
			kBtuh	kW		75°F 24°C	80°F 27°C	85°F 29°C	kBtuh	kW		75°F 24°C	80°F 27°C	85°F 29°C	kBtuh	kW		75°F 24°C	80°F 27°C	85°F 29°C	kBtuh	kW		75°F 24°C	80°F 27°C	85°F 29°C
63°F (17°C)	3200	1510	119.0	34.9	6.45	.68	.83	.99	113.3	33.2	7.34	.69	.86	1.00	107.2	31.4	8.36	.71	.89	1.00	100.5	29.5	9.54	.73	.93	1.00
	4000	1890	123.7	36.3	6.49	.74	.93	1.00	117.9	34.6	7.38	.76	.96	1.00	111.7	32.7	8.40	.79	.99	1.00	105.5	30.9	9.57	.82	1.00	1.00
	4800	2265	128.2	37.6	6.51	.81	1.00	1.00	122.7	36.0	7.41	.83	1.00	1.00	116.7	34.2	8.43	.87	1.00	1.00	110.1	32.3	9.60	.91	1.00	1.00
67°F (19°C)	3200	1510	126.6	37.1	6.51	.53	.66	.79	120.4	35.3	7.40	.54	.67	.82	113.8	33.4	8.42	.55	.69	.85	106.7	31.3	9.58	.56	.71	.89
	4000	1890	130.8	38.3	6.54	.56	.71	.89	124.4	36.5	7.43	.57	.73	.92	117.4	34.4	8.45	.59	.76	.96	109.7	32.1	9.61	.60	.80	.99
	4800	2265	133.8	39.2	6.57	.60	.78	.98	127.0	37.2	7.46	.61	.81	1.00	119.9	35.1	8.47	.63	.84	1.00	112.2	32.9	9.64	.65	.88	1.00
71°F (22°C)	3200	1510	135.1	39.6	6.58	.40	.51	.63	128.5	37.7	7.48	.40	.52	.65	121.4	35.6	8.49	.40	.53	.67	113.7	33.3	9.65	.41	.55	.69
	4000	1890	139.1	40.8	6.61	.41	.55	.69	132.1	38.7	7.51	.41	.56	.71	124.6	36.5	8.52	.42	.58	.73	116.5	34.1	9.68	.43	.60	.77
	4800	2265	141.8	41.6	6.64	.42	.59	.75	134.7	39.5	7.53	.43	.60	.78	126.9	37.2	8.55	.44	.62	.82	118.5	34.7	9.71	.44	.64	.86

COOLING RATINGS

10 TON HIGH EFFICIENCY MSAV - ONE COMPRESSOR OPERATING

SGA120H4M

Entering Wet Bulb Temperature	Total Air Volume		Outdoor Air Temperature Entering Outdoor Coil																										
			65°F (18°C)						75°F (24°C)						85°F (29°C)						95°F (35°C)								
			Total Cooling Capacity		Comp Motor kW Input	Sensible To Total Ratio (S/T) Dry Bulb			Total Cooling Capacity		Comp Motor kW Input	Sensible To Total Ratio (S/T) Dry Bulb			Total Cooling Capacity		Comp Motor kW Input	Sensible To Total Ratio (S/T) Dry Bulb			Total Cooling Capacity		Comp Motor kW Input	Sensible To Total Ratio (S/T) Dry Bulb					
			kBtuh	kW		75°F 24°C	80°F 27°C	85°F 29°C	kBtuh	kW		75°F 24°C	80°F 27°C	85°F 29°C	kBtuh	kW		75°F 24°C	80°F 27°C	85°F 29°C	kBtuh	kW		75°F 24°C	80°F 27°C	85°F 29°C			
63°F (17°C)	2400	1135	69.8	20.5	2.34	.74	.94	1.00	67.1	19.7	2.73	.76	.96	1.00	64.0	18.8	3.14	.78	1.00	1.00	61.2	17.9	3.58	.80	1.00	1.00			
	3000	1415	73.6	21.6	2.35	.82	1.00	1.00	70.9	20.8	2.74	.85	1.00	1.00	67.9	19.9	3.15	.88	1.00	1.00	64.8	19.0	3.59	.92	1.00	1.00			
	3600	1700	77.0	22.6	2.36	.92	1.00	1.00	74.0	21.7	2.75	.96	1.00	1.00	70.8	20.7	3.16	.99	1.00	1.00	67.5	19.8	3.61	1.00	1.00	1.00			
67°F (19°C)	2400	1135	74.2	21.7	2.35	.57	.72	.90	70.9	20.8	2.74	.58	.74	.93	67.6	19.8	3.15	.59	.76	.97	64.0	18.8	3.59	.60	.78	1.00			
	3000	1415	76.4	22.4	2.36	.61	.79	1.00	73.0	21.4	2.75	.63	.82	1.00	69.6	20.4	3.16	.64	.85	1.00	65.8	19.3	3.60	.66	.89	1.00			
	3600	1700	78.4	23.0	2.37	.66	.89	1.00	74.7	21.9	2.76	.68	.93	1.00	71.1	20.8	3.17	.69	.97	1.00	67.5	19.8	3.61	.71	1.00	1.00			
71°F (22°C)	2400	1135	79.3	23.2	2.37	.41	.55	.70	75.8	22.2	2.76	.41	.56	.71	72.1	21.1	3.17	.42	.58	.73	68.3	20.0	3.62	.42	.59	.76			
	3000	1415	81.4	23.9	2.38	.43	.60	.77	77.7	22.8	2.77	.43	.62	.79	73.9	21.7	3.19	.44	.63	.82	69.9	20.5	3.63	.45	.65	.86			
	3600	1700	82.8	24.3	2.38	.45	.65	.86	79.0	23.2	2.78	.46	.67	.90	75.1	22.0	3.19	.46	.69	.94	71.0	20.8	3.64	.47	.71	.98			

10 TON HIGH EFFICIENCY MSAV - ALL COMPRESSORS OPERATING

SGA120H4M

Entering Wet Bulb Temperature	Total Air Volume		Outdoor Air Temperature Entering Outdoor Coil																										
			85°F (29°C)						95°F (35°C)						105°F (41°C)						115°F (46°C)								
			Total Cooling Capacity		Comp Motor kW Input	Sensible To Total Ratio (S/T) Dry Bulb			Total Cooling Capacity		Comp Motor kW Input	Sensible To Total Ratio (S/T) Dry Bulb			Total Cooling Capacity		Comp Motor kW Input	Sensible To Total Ratio (S/T) Dry Bulb			Total Cooling Capacity		Comp Motor kW Input	Sensible To Total Ratio (S/T) Dry Bulb					
			kBtuh	kW		75°F 24°C	80°F 27°C	85°F 29°C	kBtuh	kW		75°F 24°C	80°F 27°C	85°F 29°C	kBtuh	kW		75°F 24°C	80°F 27°C	85°F 29°C	kBtuh	kW		75°F 24°C	80°F 27°C	85°F 29°C			
63°F (17°C)	3200	1510	118.9	34.8	6.59	.70	.85	.99	113.3	33.2	7.60	.71	.87	1.00	107.3	31.4	8.54	.73	.90	1.00	100.7	29.5	9.75	.75	.93	1.00			
	4000	1890	123.6	36.2	6.63	.76	.94	1.00	117.9	34.6	7.54	.78	.96	1.00	111.8	32.8	8.58	.80	.99	1.00	105.6	30.9	9.78	.84	1.00	1.00			
	4800	2265	128.1	37.5	6.65	.82	1.00	1.00	122.7	36.0	7.57	.85	1.00	1.00	116.7	34.2	8.62	.88	1.00	1.00	110.3	32.3	9.81	.91	1.00	1.00			
67°F (19°C)	3200	1510	128.5	37.1	6.65	.56	.68	.81	120.4	35.3	7.56	.56	.69	.83	113.9	33.4	8.61	.57	.71	.86	106.9	31.3	9.79	.58	.73	.90			
	4000	1890	130.8	38.3	6.68	.58	.73	.90	124.4	36.5	7.59	.59	.75	.93	117.5	34.4	8.63	.61	.78	.96	110.0	32.2	9.83	.62	.81	.99			
	4800	2265	133.7	39.2	6.71	.62	.80	.98	127.0	37.2	7.62	.63	.82	1.00	120.0	35.2	8.66	.65	.86	1.00	112.4	32.9	9.85	.67	.89	1.00			
71°F (22°C)	3200	1510	135.0	39.6	6.72	.41	.53	.65	128.5	37.7	7.64	.41	.54	.67	121.5	35.6	8.67	.42	.55	.69	113.9	33.4	9.86	.42	.56	.71			
	4000	1890	139.0	40.7	6.76	.42	.57	.71	132.1	38.7	7.67	.43	.58	.73	124.7	36.5	8.71	.43	.60	.75	116.8	34.2	9.90	.44	.61	.79			
	4800	2265	141.8	41.6	6.78	.44	.61	.77	134.6	39.4	7.70	.44	.62	.80	127.0	37.2	8.73	.45	.64	.83	118.8	34.8	9.92	.46	.66	.87			

20 TON HIGH EFFICIENCY CAV - TWO COMPRESSORS OPERATING

SGA240H4B

Entering Wet Bulb Temperature	Total Air Volume		Outdoor Air Temperature Entering Outdoor Coil																										
			65°F (18°C)						75°F (24°C)						85°F (29°C)						95°F (35°C)								
			Total Cooling Capacity		Comp Motor kW Input	Sensible To Total Ratio (S/T) Dry Bulb			Total Cooling Capacity		Comp Motor kW Input	Sensible To Total Ratio (S/T) Dry Bulb			Total Cooling Capacity		Comp Motor kW Input	Sensible To Total Ratio (S/T) Dry Bulb			Total Cooling Capacity		Comp Motor kW Input	Sensible To Total Ratio (S/T) Dry Bulb					
			kBtuh	kW		75°F 24°C	80°F 27°C	85°F 29°C	kBtuh	kW		75°F 24°C	80°F 27°C	85°F 29°C	kBtuh	kW		75°F 24°C	80°F 27°C	85°F 29°C	kBtuh	kW		75°F 24°C	80°F 27°C	85°F 29°C			
63°F (17°C)	6400	3020	125.2	36.7	4.98	.64	.79	.94	120.6	35.3	5.71	.65	.81	.96	115.9	34.0	6.52	.66	.83	.98	110.7	32.4	7.42	.67	.85	1.00			
	8000	3775	130.3	38.2	5.01	.69	.87	1.00	125.4	36.8	5.75	.70	.90	1.00	120.4	35.3	6.55	.72	.92	1.00	115.0	33.7	7.46	.74	.95	1.00			
	9600	4530	134.3	39.4	5.03	.75	.95	1.00	129.4	37.9	5.77	.77	.97	1.00	124.5	36.5	6.57	.79	.99	1.00	119.2	34.9	7.49	.82	1.00	1.00			
67°F (19°C)	6400	3020	133.2	38.0	5.02	.50	.61	.74	128.2	37.6	5.76	.51	.62	.76	123.0	36.0	6.57	.51	.63	.78	117.4	34.4	7.48	.52	.65	.81			
	8000	3775	137.6	40.3	5.05	.53	.66	.83	132.4	38.8	5.79	.53	.67	.86	126.9	37.2	6.60	.54	.69	.88	121.0	35.5	7.51	.55	.71	.91			
	9600	4530	140.9	41.3	5.07	.56	.72	.92	135.4	39.7	5.82	.56	.74	.94	129.7	38.0	6.63	.57	.76	.97	123.5	36.2	7.54	.59	.79	.99			
71°F (22°C)	6400	3020	142.0	41.6	5.07	.38	.49	.59	136.7	40.1	5.82	.38	.49	.60	131.1	38.4	6.64	.38	.50	.61	125.1	36.7	7.55	.38	.51	.63			
	8000	3775	146.5	42.9	5.11	.39	.51	.64	140.8	41.3	5.86	.39	.52	.65	134.9	39.5	6.66	.39	.53	.67	128.6	37.7	7.58	.40	.54	.69			
	9600	4530	149.5	43.8	5.13	.40	.55	.69	143.6	42.1	5.88	.40	.55	.71	137.4	40.3	6.70	.41	.57	.74	130.7	38.3	7.60	.41	.58	.76			

20 TON HIGH EFFICIENCY CAV - ALL COMPRESSORS OPERATING

SGA240H4B

Entering Wet Bulb Temperature	Total Air Volume		Outdoor Air Temperature Entering Outdoor Coil																										
			85°F (29°C)						95°F (35°C)						105°F (41°C)						115°F (46°C)								
			Total Cooling Capacity		Comp Motor kW Input	Sensible To Total Ratio (S/T) Dry Bulb			Total Cooling Capacity		Comp Motor kW Input	Sensible To Total Ratio (S/T) Dry Bulb			Total Cooling Capacity		Comp Motor kW Input	Sensible To Total Ratio (S/T) Dry Bulb			Total Cooling Capacity		Comp Motor kW Input	Sensible To Total Ratio (S/T) Dry Bulb					
			kBtuh	kW		75°F 24°C	80°F 27°C	85°F 29°C	kBtuh	kW		75°F 24°C	80°F 27°C	85°F 29°C	kBtuh	kW		75°F 24°C	80°F 27°C	85°F 29°C	kBtuh	kW		75°F 24°C	80°F 27°C	85°F 29°C			
63°F (17°C)	6400	3020	238.1	69.8	13.17	.72	.86	.99	227.5	66.7	15.00	.73	.88	1.00	216.0	63.3	17.08	.75	.91	1.00	203.4	59.6	19.53	.77	.93	1.00			
	8000	3775	247.3	72.5	13.24	.77	.94	1.00	236.3	69.3	15.08	.79	.96	1.00	224.6	65.8	17.16	.81	.98	1.00	212.3	62.2	19.60	.84	1.00	1.00			
	9600	4530	255.7	74.9	13.28	.83	.99	1.00	244.9	71.8	15.12	.85	1.00	1.00	233.6	68.5	17.24	.88	1.00	1.00	221.3	64.9	19.67	.91	1.00	1.00			
67°F (19°C)	6400	3020	252.9	74.1	13.28	.56	.69	.82	241.4	70.7	15.12	.57	.71	.85	229.1	67.1	17.21	.58	.72	.87	215.4	63.1	19.63	.59	.75	.90			
	8000	3775	261.1	76.5	13.33	.59	.75	.91	248.7	72.9	15.19	.60	.77	.93	235.7	69.1	17.28	.62	.79	.96	221.5	64.9	19.68	.63	.82	.98			
	9600	4530	268.8	78.2	13.40	.63	.81	.97	254.1	74.5	15.24	.64	.83	.99	240.6	70.5	17.32	.66	.86	1.00	226.1	66.3	19.75	.68	.89	1.00			
71°F (22°C)	6400	3020	269.8	79.1	13.42	.42	.54	.67	257.5	75.5	15.24	.42	.55	.68	244.0	71.5	17.35	.43	.56	.70	229.4	67.2	19.77	.43	.58	.72			
	8000	3775	277.5	81.3	13.49	.43	.58	.73	264.5	77.5	15.31	.44	.59	.75	250.3	73.4	17.43	.44	.61	.77	235.1	68.9	19.83	.45	.62	.80			
	9600	4530	282.8	82.9	13.54	.44	.62	.79	269.2	78.9	15.37	.45	.63	.81	254.7	74.6	17.47	.46	.65	.84	238.9	70.0	19.87	.47	.67	.87			

COOLING RATINGS

20 TON HIGH EFFICIENCY MSAV - TWO COMPRESSORS OPERATING

SGA240H4M

Entering Wet Bulb Temperature	Total Air Volume		Outdoor Air Temperature Entering Outdoor Coil																							
			65°F (18°C)						75°F (24°C)						85°F (29°C)						95°F (35°C)					
			Total Cooling Capacity		Comp Motor kW Input	Sensible To Total Ratio (S/T) Dry Bulb			Total Cooling Capacity		Comp Motor kW Input	Sensible To Total Ratio (S/T) Dry Bulb			Total Cooling Capacity		Comp Motor kW Input	Sensible To Total Ratio (S/T) Dry Bulb			Total Cooling Capacity		Comp Motor kW Input	Sensible To Total Ratio (S/T) Dry Bulb		
			kBtuh	kW		75°F 24°C	80°F 27°C	85°F 29°C	kBtuh	kW		75°F 24°C	80°F 27°C	85°F 29°C	kBtuh	kW		75°F 24°C	80°F 27°C	85°F 29°C	kBtuh	kW		75°F 24°C	80°F 27°C	85°F 29°C
63°F (17°C)	4800	2265	135.1	39.6	5.02	.79	.91	1.00	130.4	38.2	5.76	.80	.93	1.00	125.4	36.8	6.58	.81	.94	1.00	119.9	35.1	7.50	.82	.96	1.00
	6000	2830	141.8	41.6	5.05	.83	.97	1.00	136.6	40.0	5.80	.84	.99	1.00	131.2	38.5	6.62	.85	1.00	1.00	125.4	36.8	7.53	.86	1.00	1.00
	7200	3400	146.7	43.0	5.08	.87	1.00	1.00	141.2	41.4	5.82	.88	1.00	1.00	135.5	39.7	6.65	.90	1.00	1.00	129.4	37.9	7.57	.92	1.00	1.00
67°F (19°C)	4800	2265	144.6	42.4	5.07	.64	.75	.87	139.5	40.9	5.81	.64	.76	.88	134.1	39.3	6.63	.65	.77	.90	128.2	37.6	7.56	.65	.78	.91
	6000	2830	151.3	44.3	5.10	.66	.80	.93	145.7	42.7	5.85	.66	.81	.95	139.8	41.0	6.67	.67	.82	.97	133.5	39.1	7.59	.68	.83	.99
	7200	3400	155.8	45.7	5.13	.68	.84	1.00	149.9	43.9	5.88	.69	.86	1.00	143.7	42.1	6.71	.70	.87	1.00	137.0	40.2	7.62	.71	.89	1.00
71°F (22°C)	4800	2265	154.7	45.3	5.12	.50	.61	.72	149.3	43.8	5.87	.50	.61	.73	143.4	42.0	6.69	.50	.62	.74	137.1	40.2	7.63	.50	.63	.75
	6000	2830	161.5	47.3	5.15	.50	.63	.76	155.6	45.6	5.91	.50	.64	.78	149.1	43.7	6.74	.50	.65	.79	142.4	41.7	7.67	.51	.66	.80
	7200	3400	166.2	48.7	5.19	.51	.66	.81	159.9	46.9	5.95	.51	.67	.82	153.2	44.9	6.77	.51	.68	.84	146.0	42.8	7.70	.52	.69	.86

20 TON HIGH EFFICIENCY MSAV - ALL COMPRESSORS OPERATING

SGA240H4M

Entering Wet Bulb Temperature	Total Air Volume		Outdoor Air Temperature Entering Outdoor Coil																							
			85°F (29°C)						95°F (35°C)						105°F (41°C)						115°F (46°C)					
			Total Cooling Capacity		Comp Motor kW Input	Sensible To Total Ratio (S/T) Dry Bulb			Total Cooling Capacity		Comp Motor kW Input	Sensible To Total Ratio (S/T) Dry Bulb			Total Cooling Capacity		Comp Motor kW Input	Sensible To Total Ratio (S/T) Dry Bulb			Total Cooling Capacity		Comp Motor kW Input	Sensible To Total Ratio (S/T) Dry Bulb		
			kBtuh	kW		75°F 24°C	80°F 27°C	85°F 29°C	kBtuh	kW		75°F 24°C	80°F 27°C	85°F 29°C	kBtuh	kW		75°F 24°C	80°F 27°C	85°F 29°C	kBtuh	kW		75°F 24°C	80°F 27°C	85°F 29°C
63°F (17°C)	6400	3020	237.9	69.7	13.16	.70	.85	.98	227.2	66.6	14.99	.72	.87	1.00	215.6	63.2	17.09	.74	.90	1.00	202.8	59.4	19.53	.76	.93	1.00
	8000	3775	247.0	72.4	13.24	.76	.93	1.00	235.8	69.1	15.07	.78	.95	1.00	224.0	65.6	17.16	.80	.98	1.00	211.6	62.0	19.57	.83	1.00	1.00
	9600	4530	255.2	74.8	13.30	.82	.99	1.00	244.5	71.7	15.12	.84	1.00	1.00	233.1	68.3	17.24	.87	1.00	1.00	220.7	64.7	19.65	.90	1.00	1.00
67°F (19°C)	6400	3020	253.0	74.1	13.28	.55	.68	.81	241.3	70.7	15.11	.56	.69	.83	228.8	67.1	17.21	.57	.71	.86	214.9	63.0	19.65	.58	.73	.89
	8000	3775	261.1	76.5	13.36	.58	.74	.90	248.6	72.9	15.20	.59	.75	.92	235.5	69.0	17.28	.61	.78	.95	221.1	64.8	19.69	.62	.81	.98
	9600	4530	266.8	78.2	13.40	.62	.80	.97	254.0	74.4	15.24	.63	.82	.99	240.3	70.4	17.33	.65	.85	1.00	225.7	66.1	19.73	.66	.88	1.00
71°F (22°C)	6400	3020	269.8	79.1	13.43	.41	.53	.66	257.4	75.4	15.25	.42	.54	.67	243.9	71.5	17.35	.42	.55	.69	229.1	67.1	19.78	.42	.57	.71
	8000	3775	277.7	81.4	13.50	.42	.57	.71	264.3	77.5	15.33	.43	.58	.73	250.3	73.4	17.41	.43	.60	.75	234.9	68.8	19.82	.44	.61	.78
	9600	4530	283.1	83.0	13.56	.44	.61	.77	269.3	78.9	15.37	.44	.62	.80	254.6	74.6	17.46	.45	.64	.83	238.7	70.0	19.87	.46	.66	.86

BLOWER DATA

SGA036H AND SGA060H BLOWER PERFORMANCE

NOTE - Blower Table Includes Resistance For Base Unit With Gas Heat, Wet Indoor Coil And Air Filters In Place.

Air Volume cfm	TOTAL STATIC PRESSURE - Inches Water Gauge																					
	0.10		0.20		0.30		0.40		0.50		0.60		0.70		0.80		0.90		1.00		1.10	
	RPM	BHP	RPM	BHP	RPM	BHP	RPM	BHP	RPM	BHP	RPM	BHP	RPM	BHP	RPM	BHP	RPM	BHP	RPM	BHP	RPM	BHP
900	600	0.15	695	0.20	780	0.30	860	0.35	935	0.45	1005	0.55	1075	0.65	1140	0.80	1200	0.90	1260	1.05	1315	1.20
1000	620	0.15	710	0.25	795	0.30	870	0.40	945	0.50	1015	0.60	1080	0.70	1140	0.80	1200	0.90	1260	1.05	1315	1.20
1100	645	0.20	730	0.25	810	0.35	885	0.40	955	0.50	1020	0.60	1085	0.70	1145	0.80	1205	0.95	1260	1.05	1315	1.20
1200	675	0.25	755	0.30	830	0.35	900	0.45	970	0.55	1035	0.65	1095	0.75	1155	0.85	1210	1.00	1265	1.10	1320	1.25
1300	705	0.30	780	0.35	850	0.40	920	0.50	985	0.60	1045	0.70	1105	0.80	1165	0.90	1220	1.05	1275	1.15	1325	1.30
1400	735	0.35	805	0.40	875	0.45	940	0.55	1005	0.65	1065	0.75	1120	0.85	1175	0.95	1230	1.10	1285	1.20	1335	1.35
1500	765	0.40	835	0.45	900	0.55	965	0.60	1025	0.70	1080	0.80	1140	0.90	1190	1.00	1245	1.15	1295	1.25	1345	1.40
1600	800	0.45	865	0.50	925	0.60	990	0.70	1045	0.80	1100	0.85	1155	1.00	1210	1.10	1260	1.20	1310	1.35	1355	1.45
1700	835	0.50	895	0.60	955	0.65	1015	0.75	1070	0.85	1125	0.95	1175	1.05	1225	1.15	1275	1.30	1325	1.40	1370	1.55
1800	865	0.60	925	0.65	985	0.75	1040	0.85	1095	0.95	1145	1.05	1195	1.15	1245	1.25	1295	1.40	1340	1.50	1385	1.65
1900	900	0.65	960	0.75	1015	0.85	1070	0.95	1120	1.05	1170	1.15	1220	1.25	1265	1.35	1315	1.50	1360	1.60	---	---
2000	940	0.75	990	0.85	1045	0.95	1095	1.05	1145	1.15	1195	1.25	1245	1.35	1290	1.45	1335	1.60	1380	1.70	---	---
2100	975	0.85	1025	0.95	1075	1.05	1125	1.15	1175	1.25	1220	1.35	1270	1.50	1315	1.60	1360	1.70	---	---	---	---
2200	1010	1.00	1060	1.05	1110	1.15	1155	1.25	1205	1.40	1250	1.50	1295	1.60	---	---	---	---	---	---	---	---
2300	1045	1.10	1095	1.20	1145	1.30	1190	1.40	1235	1.50	1280	1.65	---	---	---	---	---	---	---	---	---	---
2400	1085	1.25	1130	1.35	1175	1.45	1220	1.55	1265	1.65	---	---	---	---	---	---	---	---	---	---	---	---
2500	1120	1.40	1165	1.50	1210	1.60	1255	1.70	---	---	---	---	---	---	---	---	---	---	---	---	---	---

BLOWER DATA

SGA120H BLOWER PERFORMANCE

NOTE - Blower Table includes Resistance For Base Unit With High Gas Heat, Wet Indoor Coil And Air Filters In Place.

¹ Air volumes from 2000 to 2800 cfm require Multi-Stage Air Volume (MSAV) blower option.

Air Volume cfm	TOTAL STATIC PRESSURE - Inches Water Gauge																			
	0.10		0.20		0.30		0.40		0.50		0.60		0.70		0.80		0.90		1.00	
	RPM	BHP	RPM	BHP	RPM	BHP	RPM	BHP	RPM	BHP	RPM	BHP	RPM	BHP	RPM	BHP	RPM	BHP	RPM	BHP
¹ 2000	485	0.40	530	0.45	575	0.55	615	0.65	655	0.75	695	0.90	730	1.00	765	1.10	795	1.20	830	1.35
¹ 2200	500	0.45	545	0.55	590	0.65	630	0.75	670	0.85	705	0.95	740	1.10	775	1.20	805	1.35	835	1.45
¹ 2400	520	0.55	565	0.65	605	0.75	645	0.85	680	0.95	715	1.05	750	1.20	785	1.30	815	1.45	845	1.55
¹ 2600	540	0.60	585	0.75	625	0.85	660	0.95	695	1.05	730	1.20	765	1.30	795	1.45	825	1.55	855	1.70
¹ 2800	565	0.75	605	0.85	640	0.95	680	1.05	715	1.20	745	1.30	780	1.45	810	1.60	840	1.70	870	1.85
3000	590	0.85	625	0.95	660	1.05	700	1.20	730	1.35	765	1.45	795	1.60	825	1.75	855	1.90	885	2.05
3200	610	0.95	650	1.10	685	1.25	715	1.35	750	1.50	780	1.60	810	1.75	840	1.90	870	2.05	895	2.20
3400	635	1.10	670	1.25	705	1.40	740	1.55	770	1.65	800	1.80	830	1.95	855	2.05	885	2.25	910	2.40
3600	660	1.30	695	1.40	725	1.55	760	1.70	790	1.85	820	2.00	845	2.10	875	2.30	900	2.45	930	2.60
3800	685	1.45	720	1.60	750	1.75	780	1.90	810	2.05	840	2.20	865	2.35	895	2.50	920	2.65	945	2.80
4000	715	1.65	745	1.80	775	1.95	805	2.10	830	2.25	860	2.40	885	2.55	915	2.75	940	2.90	965	3.10
4200	740	1.90	770	2.05	800	2.20	825	2.35	855	2.50	880	2.65	905	2.80	935	3.00	960	3.20	980	3.35
4400	765	2.10	795	2.25	825	2.45	850	2.60	875	2.75	905	2.95	930	3.10	955	3.30	---	---	---	---
4600	795	2.40	820	2.55	850	2.70	875	2.85	900	3.05	925	3.20	950	3.40	---	---	---	---	---	---
4800	820	2.65	845	2.80	875	3.00	900	3.15	925	3.35	---	---	---	---	---	---	---	---	---	---

SGA120H POWER EXHAUST FANS STANDARD STATIC PERFORMANCE

Return Air System Static Pressure in. wg.	Air Volume Exhausted cfm
0.05	4085
0.10	3685
0.15	3280
0.20	2880
0.25	2475

BLOWER DATA

SGA240H BLOWER PERFORMANCE

NOTE - Blower Table Includes Resistance For Base Unit With High Gas Heat, Wet Indoor Coil And Air Filters In Place.

¹ Air volumes from 4000 to 5800 cfm require Multi-Stage Air Volume (MSAV) blower option.

Air Volume cfm	TOTAL STATIC PRESSURE - Inches Water Gauge																					
	0.20		0.30		0.40		0.50		0.60		0.70		0.80		0.90		1.00		1.10		1.20	
	RPM	BHP	RPM	BHP	RPM	BHP	RPM	BHP	RPM	BHP	RPM	BHP	RPM	BHP	RPM	BHP	RPM	BHP	RPM	BHP	RPM	BHP
¹ 4000	415	0.60	450	0.75	480	0.85	515	1.00	550	1.15	585	1.30	615	1.45	640	1.60	670	1.80	695	1.95	720	2.15
¹ 4200	420	0.65	455	0.80	485	0.90	520	1.05	555	1.20	585	1.35	615	1.50	645	1.70	675	1.90	700	2.05	725	2.25
¹ 4400	425	0.70	455	0.80	490	0.95	525	1.10	560	1.25	590	1.40	620	1.60	650	1.80	675	1.95	705	2.15	730	2.35
¹ 4600	430	0.75	460	0.85	495	1.00	530	1.15	565	1.35	595	1.50	625	1.70	655	1.85	680	2.05	705	2.20	730	2.40
¹ 4800	435	0.80	465	0.90	500	1.05	535	1.25	570	1.40	600	1.60	630	1.75	660	1.95	685	2.15	710	2.30	735	2.50
¹ 5000	440	0.85	470	1.00	505	1.15	540	1.30	575	1.50	605	1.65	635	1.85	665	2.05	690	2.25	715	2.40	740	2.60
¹ 5200	445	0.90	480	1.05	515	1.20	550	1.40	580	1.55	610	1.75	640	1.95	670	2.15	695	2.35	720	2.55	745	2.75
¹ 5400	450	0.95	485	1.15	520	1.30	555	1.50	585	1.65	615	1.85	645	2.05	675	2.25	700	2.45	725	2.65	750	2.85
¹ 5600	455	1.05	490	1.20	525	1.35	560	1.55	590	1.75	620	1.95	650	2.15	680	2.35	705	2.55	730	2.75	755	2.95
¹ 5800	460	1.10	495	1.25	530	1.45	565	1.65	595	1.80	625	2.00	655	2.25	685	2.45	710	2.65	735	2.85	760	3.10
6000	465	1.15	500	1.35	535	1.50	570	1.75	600	1.90	635	2.15	660	2.35	690	2.55	715	2.80	740	3.00	765	3.25
6200	475	1.25	510	1.45	545	1.65	575	1.80	610	2.05	640	2.25	665	2.45	695	2.70	720	2.90	745	3.10	770	3.35
6400	480	1.35	515	1.50	550	1.70	585	1.95	615	2.15	645	2.35	670	2.55	700	2.80	725	3.00	750	3.25	775	3.50
6600	485	1.40	520	1.60	555	1.80	590	2.05	620	2.25	650	2.45	680	2.70	705	2.95	730	3.15	755	3.40	780	3.65
6800	495	1.50	530	1.70	565	1.95	595	2.15	625	2.35	655	2.60	685	2.85	710	3.05	735	3.30	760	3.50	785	3.80
7000	500	1.60	535	1.80	570	2.05	600	2.25	635	2.50	660	2.70	690	2.95	715	3.20	740	3.40	765	3.65	790	3.90
7200	505	1.65	545	1.90	575	2.15	610	2.40	640	2.60	665	2.80	695	3.10	720	3.30	745	3.55	770	3.80	795	4.05
7400	515	1.80	550	2.00	585	2.25	615	2.50	645	2.75	675	3.00	700	3.20	725	3.45	750	3.70	775	3.95	800	4.25
7600	520	1.90	560	2.15	590	2.35	625	2.65	650	2.85	680	3.10	705	3.35	735	3.65	760	3.90	780	4.10	805	4.40
7800	530	2.00	565	2.25	600	2.50	630	2.75	660	3.00	685	3.25	715	3.55	740	3.80	765	4.05	785	4.25	810	4.55
8000	540	2.15	575	2.40	605	2.65	635	2.90	665	3.15	695	3.45	720	3.65	745	3.95	770	4.20	795	4.50	815	4.70
8200	545	2.25	580	2.50	615	2.80	645	3.05	670	3.30	700	3.55	725	3.80	750	4.10	775	4.35	800	4.65	820	4.90
8400	555	2.40	590	2.65	620	2.90	650	3.20	680	3.45	705	3.70	730	3.95	760	4.30	780	4.55	805	4.80	830	5.15
8600	565	2.55	595	2.80	630	3.10	655	3.30	685	3.60	715	3.90	740	4.20	765	4.45	790	4.75	810	5.00	835	5.30
8800	570	2.65	605	2.95	635	3.20	665	3.50	695	3.80	720	4.05	745	4.35	770	4.65	795	4.95	820	5.25	840	5.50
9000	580	2.80	615	3.10	645	3.40	670	3.65	700	3.95	725	4.20	750	4.50	775	4.80	800	5.10	825	5.40	845	5.70
9200	590	3.00	620	3.25	650	3.55	680	3.85	705	4.10	735	4.45	760	4.75	785	5.05	805	5.30	830	5.60	---	---
9400	595	3.10	630	3.45	660	3.75	690	4.05	715	4.30	740	4.60	765	4.90	790	5.20	815	5.55	---	---	---	---
9600	605	3.30	635	3.55	665	3.90	695	4.20	720	4.50	750	4.85	770	5.10	795	5.40	---	---	---	---	---	---

SGA240H POWER EXHAUST FANS STANDARD STATIC PERFORMANCE

Return Air System Static Pressure in. wg.	Air Volume Exhausted cfm
0.00	10,200
0.05	9700
0.10	9200
0.15	8600
0.20	8100
0.25	7600
0.30	6900
0.35	6000
0.40	5000
0.45	4500

ELECTRICAL DATA

Model No.	SGA036H4			SGA060H4			
Line voltage data - 60 Hz - 3 phase	208/230V	460V	575V	208/230V	460V	575V	
¹ Maximum Overcurrent Protection (amps)	25	15	15	40	20	15	
² Minimum Circuit Ampacity	18	11	8	28	14	11	
Compressor	Rated load amps	9	5.6	3.8	16	7.8	5.7
	Locked rotor amps	71	38	36.5	110	52	38.9
Condenser Fan Motor(s)	Number of Motors	1	1	1	2	2	2
	Full load amps - each (total)	0.9	0.6	0.5	0.9 (1.8)	0.6 (1.2)	0.5 (1)
	Locked rotor amps - each (total)	1.3	1.1	1.1	1.3 (2.6)	1.1 (2.2)	1.1 (2.2)
Evaporator Blower Motor	Motor Output - hp	1.5	1.5	1.5	1.5	1.5	1.5
	Full load amps	5.7	2.8	2.4	5.7	2.8	2.4
	Locked rotor amps	40	20	13.2	40	20	13.2
Service Outlet (2) 115 volt GFCI (amp rating)	20	20	15	20	20	15	

NOTE - Extremes of operating range are plus and minus 10 % of line voltage.

1 HACR type breaker or fuse.

2 Refer to National or Canadian Electrical Code manual to determine wire, fuse and disconnect size requirements.

Model No.	SGA120H4			SGA240H4			
Line voltage data - 60 Hz - 3 phase	208/230V	460V	575V	208/230V	460V	575V	
¹ Maximum Overcurrent Protection (amps)	Unit only	60	30	25	110	50	40
	With power exhaust	70	35	25	110	60	45
² Minimum Circuit Ampacity	Unit only	54	27	20	100	49	37
	With power exhaust	57	28	21	107	53	40
Compressors	Number	2	2	2	4	4	4
	Rated load amps - each (total)	15.9 (31.9)	7.8 (15.6)	5.7 (11.4)	16.0 (63.8)	7.8 (31.2)	5.7 (22.8)
	Locked rotor amps - each (total)	110 (220)	52 (104)	38.9 (77.8)	110 (440)	52 (208)	38.9 (155.6)
Condenser Fan Motors	Number	3	3	3	6	6	6
	Full load amps - each (total)	2.4 (7.2)	1.3 (3.9)	1 (3)	2.4 (14.4)	1.3 (7.8)	1 (6)
	Locked rotor amps - each (total)	4.7 (14.1)	2.4 (7.2)	1.9 (5.7)	4.7 (28.2)	2.4 (14.4)	1.9 (11.4)
Evaporator Blower Motor	Motor Output - hp	3	3	3	5	5	5
	Full load amps	10.6	4.8	3.9	16.7	7.6	6.1
	Locked rotor amps	58.0	26.8	16.2	105	45.6	36.6
Optional Power Exhaust Fan	(Number) Horsepower	(1) 1/2	(1) 1/2	(1) 1/2	(3) 1/3	(3) 1/3	(3) 1/3
	Full load amps	3.0	1.5	1.2	2.4 (7.2)	1.3 (3.9)	1 (3)
	Locked rotor amps	6.0	3.0	2.9	3.1 (9.4)	1.6 (4.8)	1.9 (5.8)
Service Outlet (2) 115 volt GFCI (amp rating)	20	20	15	20	20	15	

NOTE - Extremes of operating range are plus and minus 10 % of line voltage.

1 HACR type breaker or fuse.

2 Refer to National or Canadian Electrical Code manual to determine wire, fuse and disconnect size requirements.

HIGH ALTITUDE DERATE

Units may be installed at altitudes up to 2000 feet above sea level without any modification. At altitudes above 2000 feet, units must be derated to match gas manifold pressures shown in table below.

Altitude - feet	Gas Manifold Pressure - in. w.g.	
	Natural Gas	LPG/Propane
2001 - 3000	3.6	10.2
3001 - 4000	3.5	9.9
4001 - 5000	3.4	9.6
5001 - 6000	3.3	9.4
6001 - 7000	3.2	9.1
7001 - 8000	3.1	8.8

OUTDOOR SOUND DATA

Unit Model No.	Octave Band Sound Power Levels dBA, re 10 ⁻¹² Watts							¹ Sound Rating Number (dB)
	Center Frequency - HZ							
	125	250	500	1000	2000	4000	8000	
036	78	75	74	72	68	62	55	76
060	79	79	76	73	68	63	56	78
120	91	89	87	83	78	73	68	88
240	94	91	90	87	83	79	72	92

¹ Tested according to ARI Standard 270-95 test conditions and ANSI Standard S1.32-1981.

UNIT CLEARANCES - INCHES (MM)

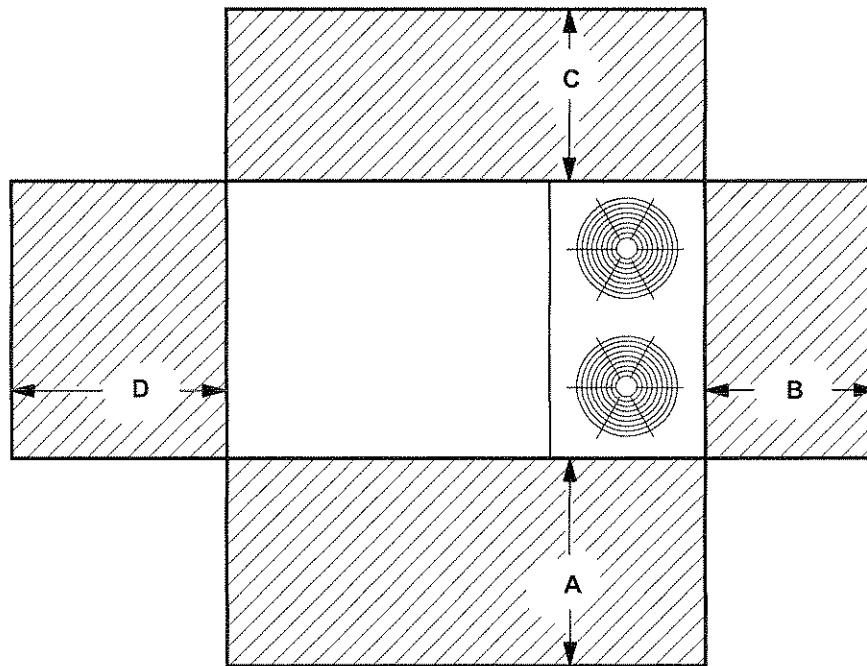

¹ Unit Clearance	A		B		C		D		Top Clearance	
	in.	mm	in.	mm	in.	mm	in.	mm		
Service Clearance	036	48	1219	36	914	60	1524	60	1524	Unobstructed
	060									
	120	60	1524	36	914	60	1524	60	1524	
240	72	1829	36	914	60	1524	96	2438		
Clearance to Combustibles	All	36	914	1	25	1	25	1	25	
Minimum Operation Clearance	All	36	914	36	914	36	914	36	914	

NOTE - Entire perimeter of unit base requires support when elevated above the mounting surface.

¹ Service Clearance - Required for removal of serviceable parts.

Clearance to Combustibles - Required clearance to combustible material.

Minimum Operation Clearance - Required clearance for proper unit operation.

WEIGHT DATA

Model Number	Net		Shipping	
	lbs.	kg	lbs.	kg
SGA036 Standard Unit	1018	462	1118	507
SGA036 Max Unit	1063	482	1163	528
SGA060 Standard Unit	1042	473	1142	518
SGA060 Max Unit	1087	493	1187	538
SGA120 Standard Unit	1785	809	1904	864
SGA120 Max Unit	1860	844	1979	898
SGA240 Standard Unit	3000	1360	3100	1406
SGA240 Max Unit	3275	1485	3375	1530

Max. Unit - The standard unit with ALL OPTIONS Installed. (Economizer and controls)

OPTIONS / ACCESSORIES

		Weight	
		lbs.	kg.
ECONOMIZER / OUTDOOR AIR / EXHAUST			
Economizer	036 or 060	45	20
	120	47	21
	240	119	54
Outdoor Air Dampers	036 or 060	24	11
	120	26	12
	240	68	31
Power Exhaust	120	28	13
	240	99	45
Heat Exchanger	120 or 240	80	36
PACKAGING			
LTL Packaging (less than truck load)	036 or 060	90	41
	120	105	48
	240	300	136
ROOF CURBS			
14 in. (356 mm) height	036 or 060	100	45
	120	126	57
	240	160	73
24 in. (610 mm) height	036 or 060	172	78
	120	174	79
	240	220	100

DIMENSIONS - INCHES (MM)

SGA036H AND SGA060H

Model Number	CORNER WEIGHTS						CENTER OF GRAVITY					
	AA		BB		CC		DD		EE		FF	
	lbs.	kg	lbs.	kg	lbs.	kg	lbs.	kg	inch	mm	inch	mm
SGA036H Standard Unit	228	103	246	112	286	130	258	117	37-1/2	953	30-3/4	781
SGA036H Max. Unit	238	108	257	117	299	136	269	122	37-1/2	953	30-3/4	781
SGA060H Standard Unit	233	105	252	114	293	133	264	120	37-1/2	953	30-3/4	781
SGA060H Max. Unit	243	110	263	120	305	140	275	125	37-1/2	953	30-3/4	781

Max. Unit - The standard unit with ALL OPTIONS installed. (Economizer and controls)

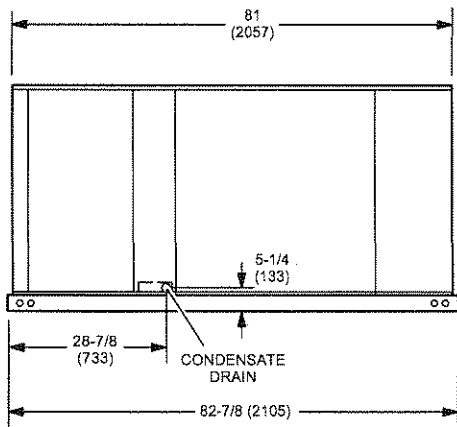
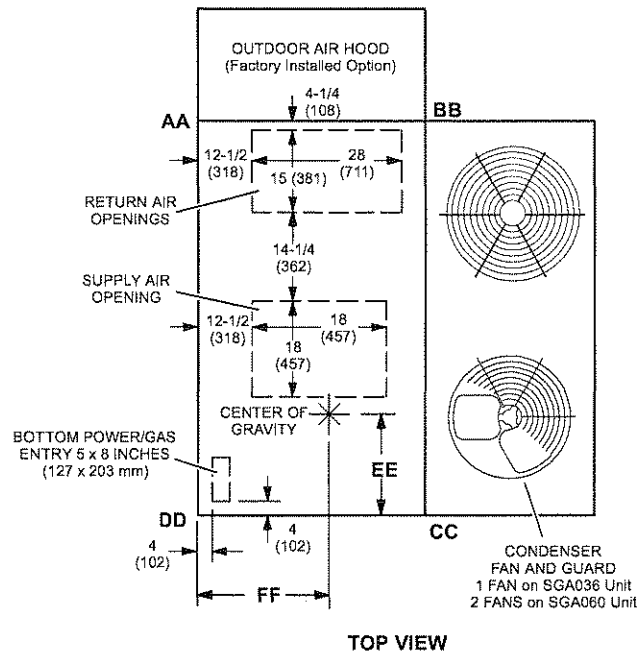

SIDE VIEW

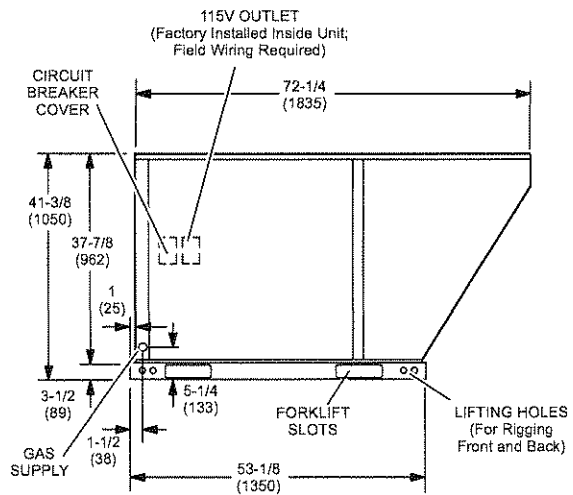

FRONT VIEW

DIMENSIONS - INCHES (MM)

SGA120H

Model Number	CORNER WEIGHTS								CENTER OF GRAVITY			
	AA		BB		CC		DD		EE		FF	
	lbs.	kg	lbs.	kg	lbs.	kg	lbs.	kg	inch	mm	inch	mm
SGA120H Standard Unit	428	194	428	194	465	211	465	211	42-3/4	1086	38-5/8	981
SGA120H Max. Unit	446	202	446	202	484	220	484	220	42-3/4	1086	38-5/8	981

Max. Unit — The standard unit with ALL OPTIONS installed. (Economizer, Power Exhaust Fan, Controls)

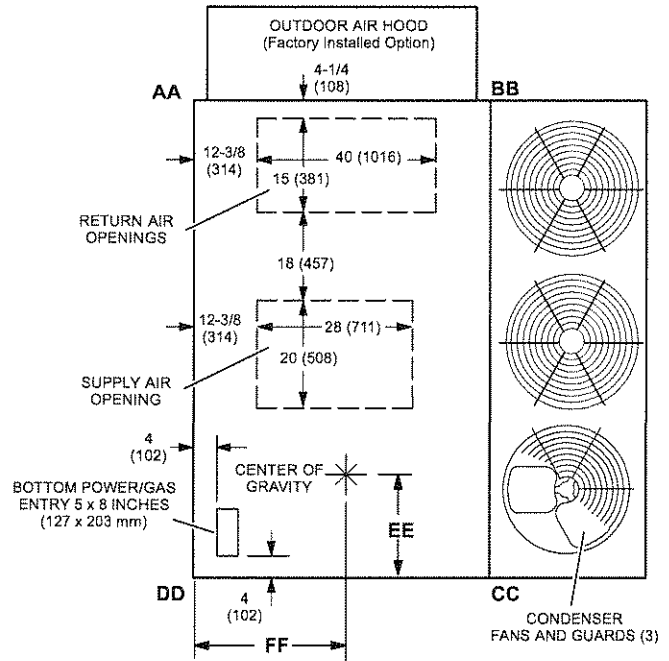

TOP VIEW

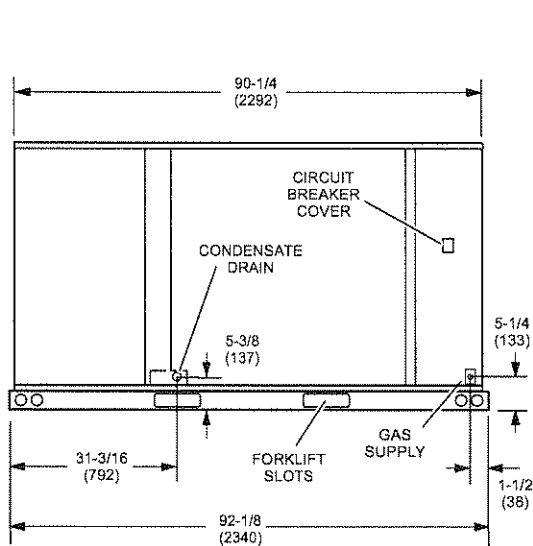

SIDE VIEW

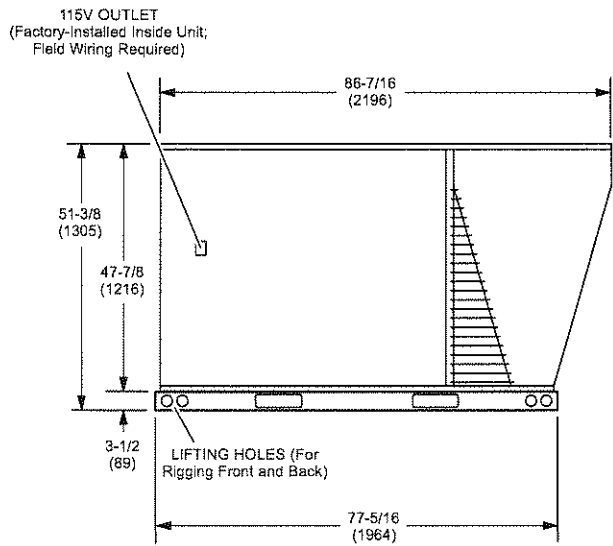

FRONT VIEW

DIMENSIONS - INCHES (MM)

SGA240H

Model Number	CORNER WEIGHTS								CENTER OF GRAVITY			
	AA		BB		CC		DD		EE		FF	
	lbs.	kg	lbs.	kg	lbs.	kg	lbs.	kg	inch	mm	inch	mm
SGA240H Standard Unit	702	318	729	330	802	363	766	347	40	1016	62-1/4	1581
SGA240H Max. Unit	802	364	802	364	835	379	835	379	43-1/4	1099	60-1/4	1530

Max. Unit — The standard unit with ALL OPTIONS installed. (Economizer, Power Exhaust Fans, Controls)

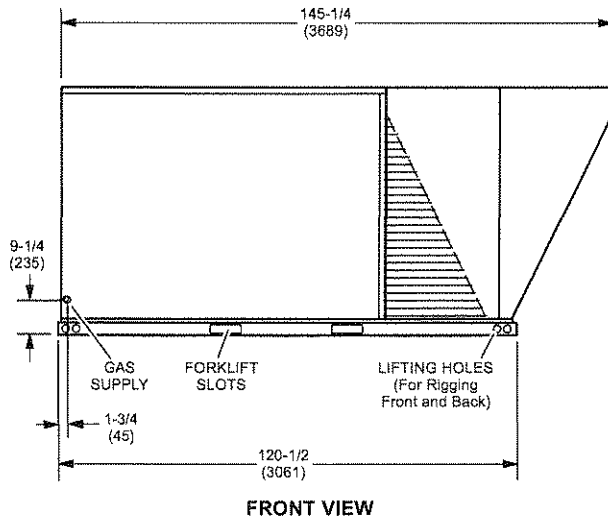
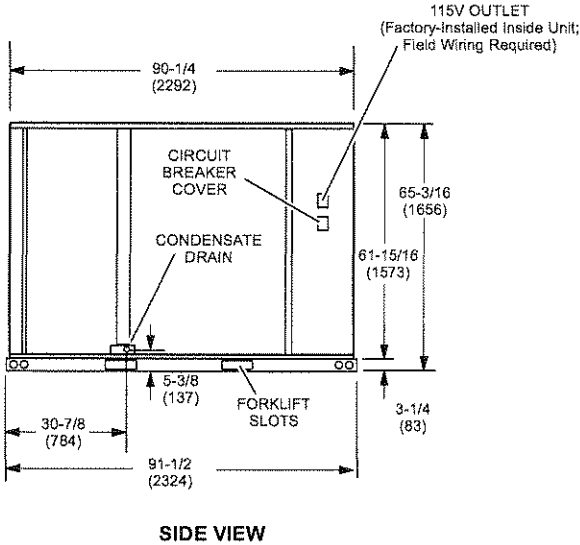
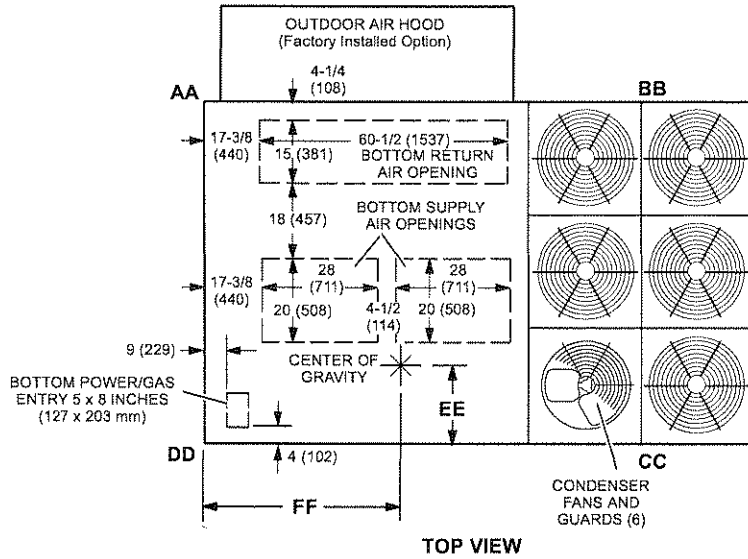

ACCESSORY DIMENSIONS - INCHES (MM)

**OPTIONAL OUTDOOR AIR HOOD DETAIL
SGA036 or SGA060**

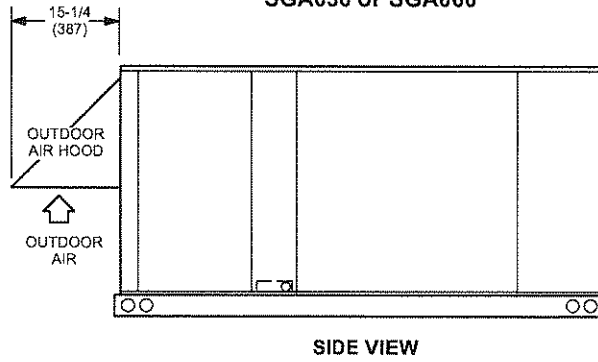

**OPTIONAL OUTDOOR AIR HOOD DETAIL
OPTIONAL POWER EXHAUST DETAIL
SGA120H**

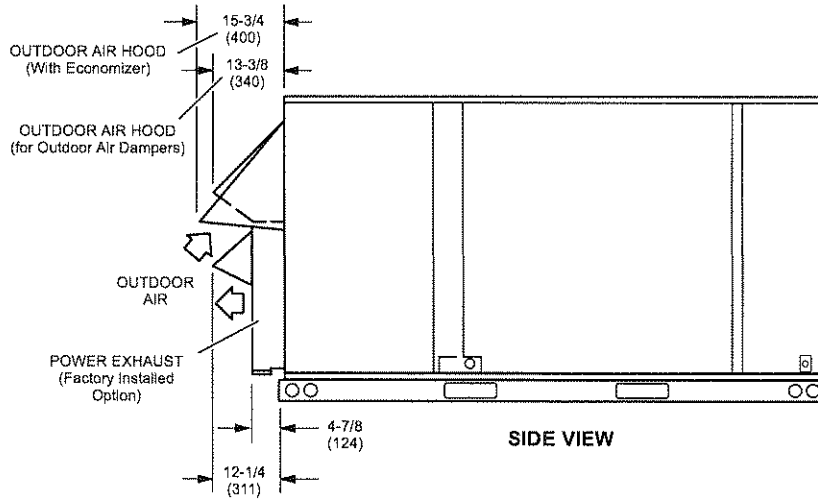

**OPTIONAL OUTDOOR AIR HOOD DETAIL
SGA240H**

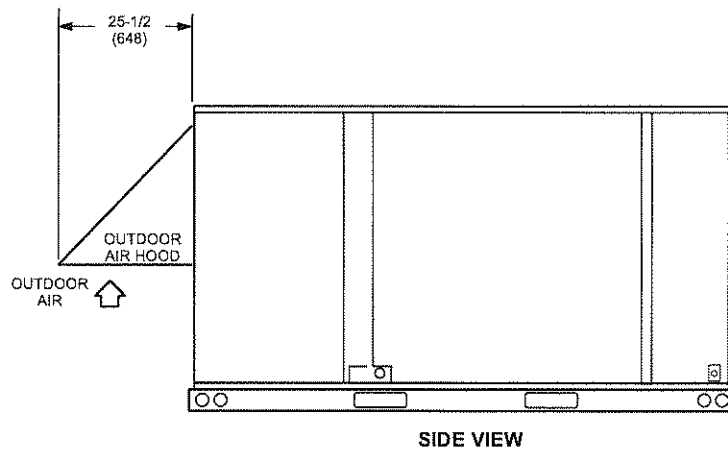

ACCESSORY DIMENSIONS - INCHES (MM)

ROOF MOUNTING FRAME WITH DOUBLE DUCT OPENING - SGA036H / SGA060H

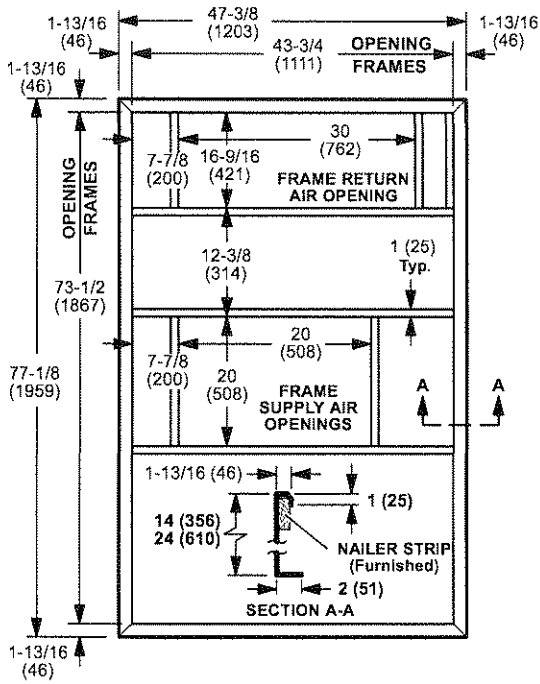

TOP VIEW

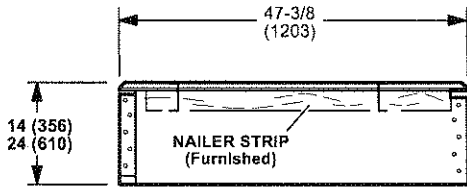

SIDE VIEW

NOTE — Roof deck may be omitted within confines of frame.

ROOF MOUNTING FRAME WITH DOUBLE DUCT OPENING - SGA120H

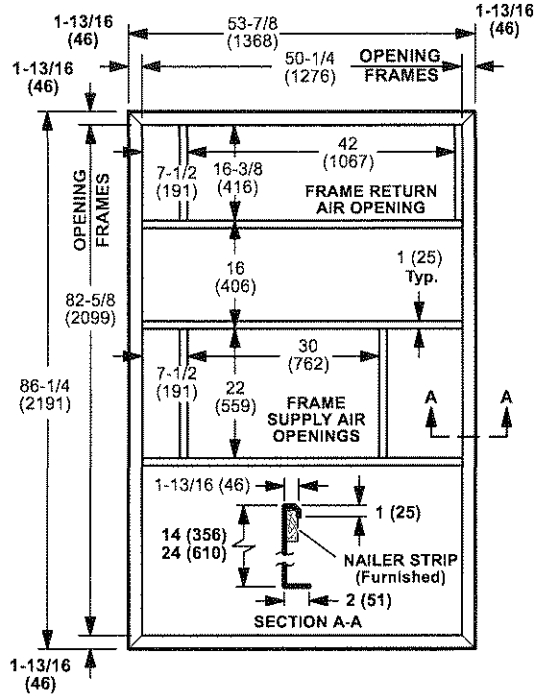

TOP VIEW

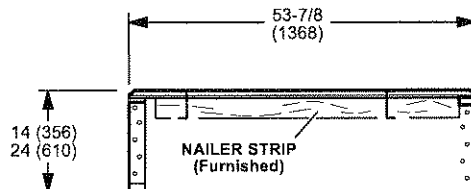

SIDE VIEW

NOTE — Roof deck may be omitted within confines of frame.

TYPICAL FLASHING DETAIL FOR ROOF MOUNTING FRAME

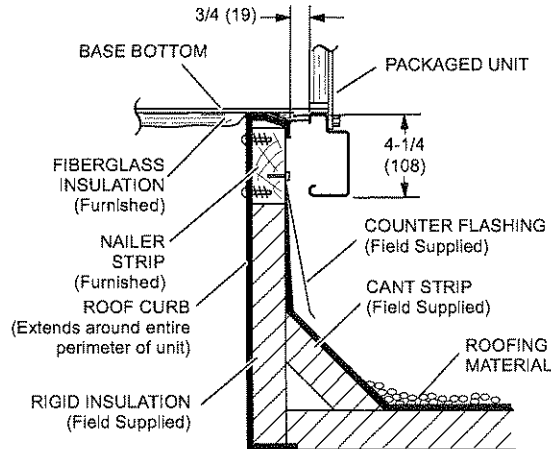

ACCESSORY DIMENSIONS - INCHES (MM)

ROOF MOUNTING FRAME WITH DOUBLE DUCT OPENING - SGA240H

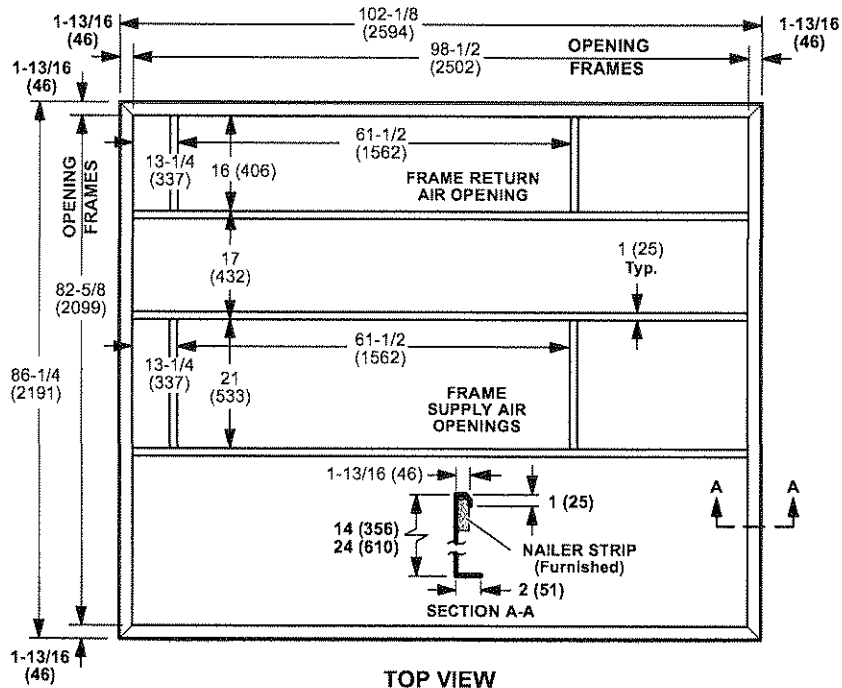

TOP VIEW

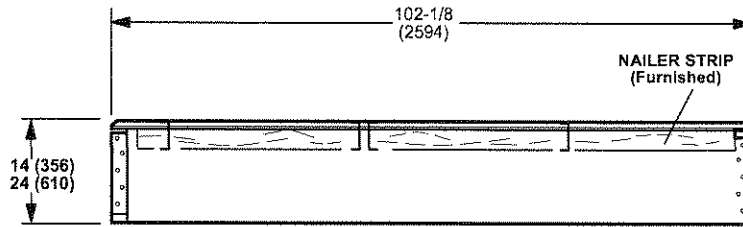

SIDE VIEW

NOTE — Roof deck may be omitted within confines of frame.

TYPICAL FLASHING DETAIL FOR ROOF MOUNTING FRAME

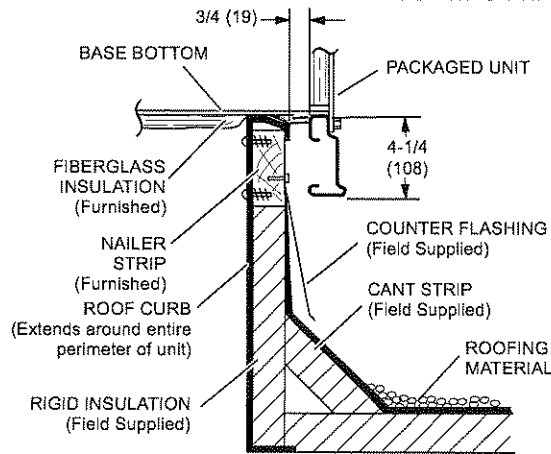

GUIDE SPECIFICATIONS

This specification specifies **[Lennox' SG and SC High efficiency]** packaged rooftop units. **[These products are manufactured by Lennox Industries Inc.]** Revise section number and title below to suit project requirements, specification practices and section content. Refer to CSI *MasterFormat* for other section numbers and titles.

Optional text and text that requires a decision are indicated by **bold brackets []** and proprietary information is indicated by **bold-italic brackets []**; delete text that is not needed in final copy of specification. Specifier Notes typically precede specification text; delete notes in final copy of specification. Trade/brand names with appropriate symbols typically are used in Specifier Notes; symbols are not used in specification text. Metric conversion, where used, is soft metric conversion.

SECTION 15730

PACKAGED, OUTDOOR, HEATING AND COOLING MAKEUP AIR-CONDITIONERS

PART 1 GENERAL

PART 1.01 SUMMARY

A. Section Includes:

1. Constant Air Volume (CAV) System: 3, 5, 10 and 20 ton packaged gas/electric and electric/electric rooftop units
2. Multi-stage Air Volume (MSAV) System: 10 and 20 ton packaged gas/electric and electric/electric rooftop units

Specifier Note: Revise paragraph below to suit project requirements. Add section numbers and titles per CSI *MasterFormat* and specifier's practice.

B. Related Sections:

Specifier Note: Article below may be omitted when specifying manufacturer's proprietary products and recommended installation. Retain Reference Article when specifying products and installation by an industry reference standard. If retained, list standard(s) referenced in this section. Indicate issuing authority name, acronym, standard designation and title. Establish policy for indicating edition date of standard referenced. Conditions of the Contract or Division 1 References Section may establish the edition date of standards. This article does not require compliance with standard, but is merely a listing of references used. Article below should list only those industry standards referenced in this section. Retain only those reference standards to be used within the text of this Section. Add and delete as required for specific project.

PART 1.02 REFERENCES

A. Agency Listings

1. Environmental Testing Laboratories (ETL) a division of Intertek Testing Laboratories
2. Canadian Standards Association (CSA)

B. Heating efficiency certifications:

1. Gas Appliance Manufacturers Association (GAMA), if applicable
2. Canadian Standards Association (CSA)

C. Safety Standards:

1. Underwriters Laboratories Inc.® (UL)
2. Underwriters' Laboratories of Canada® (ULC)
3. National Electrical Code® (NEC)
4. Canadian Electrical (CE) Code

D. Cooling efficiency certifications or ratings:

1. ARI 210/240 – 2005, if applicable
2. ARI 340/360 – 2004, if applicable Cooling efficiency certifications or ratings:

E. Units to be Energy Star® qualified

F. Exceed ASHRAE Standard 90.1-2004

G. Manufactured in ISO 9000:2001 compliant facility

GUIDE SPECIFICATIONS

Specifier Note: Article below should be restricted to statements describing design or performance requirements and functional (not dimensional) tolerances of a complete system. Limit descriptions to composite and operational properties required to link components of a system together and to interface with other systems.

PART 1.03 SYSTEM DESCRIPTION, PERFORMANCE REQUIREMENTS:

- A. 3, 5, 10 and 20 ton capacity
- B. Gas/Electric Efficiencies
 - 1. 3 ton capacity at 400 CFM/ton:
 - a. 14.3 EER (CAV)
 - 1) 16.1 SEER (CAV)
 - b. 5 ton capacity at 330 CFM/ton:
 - 1) 12.8 EER (CAV)
 - 2) 15.5 SEER (CAV)
 - c. 10 ton capacity at 370 CFM/ton:
 - 1) 12.3 EER (CAV)/ 12.1 EER (MSAV)
 - 2) 13.2 IPLV (CAV)/ 15.0 IPLV (MASV)
 - d. 20 ton capacity at 325 CFM/ton:
 - 1) 12.6 EER (CAV)/ 12.6 EER (MSAV)
 - 2) 14.4 IPLV (CAV)/ 16.2 IPLV (MASV)
- C. Electric / Electric or Cooling Only Efficiencies
 - 1. 3 ton capacity at 400 CFM/ton:
 - a. 14.3 EER (CAV)
 - 1) 16.1 SEER (CAV)
 - b. 5 ton capacity at 330 CFM/ton:
 - 1) 12.8 EER (CAV)
 - 2) 15.5 SEER (CAV)
 - c. 10 ton capacity at 370 CFM/ton:
 - 1) 12.5 EER (CAV)/ 12.3 EER (MSAV)
 - 2) 13.5 IPLV (CAV)/ 15.2 IPLV (MASV)
 - d. 20 ton capacity at 325 CFM/ton:
 - 1) 12.8 EER (CAV)/ 12.8 EER (MSAV)
 - 2) 14.8 IPLV (CAV)/ 16.4 IPLV (MASV)
- D. Sound levels:
 - 1. 76 dB for 3 ton unit
 - a. 78 dB for 5 ton unit
 - b. 88 dB for 10 ton unit
 - c. 92 dB for 20 ton unit
- E. Electrical Characteristics:
 - 1. 60 Hz
 - a. 3-phase
 - b. **[208/230 V] [460 V] [575 V]**

GUIDE SPECIFICATIONS

Specifier Note: Article below includes submittal of relevant data to be furnished by Contractor before, during or after construction. Coordinate this article with Architect's and Contractor's duties and responsibilities in Conditions of the Contract and Division 1 Submittal Procedures Section.

PART 1.04 SUBMITTALS

- A. General: Submit listed submittals in accordance with Conditions of Contract and Division 1 Submittal Procedures
- B. Product Data:
 - 1. Submit product data
 - 2. Include manufacturer's product data sheets
- C. Shop Drawings:
 - 1. Submit shop drawings in accordance with Section [01330 - Submittal Procedures]
 - 2. Indicate:
 - a. Equipment
 - b. Piping and connections
 - c. Recommended ancillaries
 - d. Dimensions
 - e. External construction
 - f. Recommended method of installation
 - g. Mounting curb details
 - h. Sizes and location of mounting bolt holes
 - i. Include mass distribution drawings showing point loads.
 - j. Wiring diagrams for control systems
 - k. Pump and fan performance tables
 - l. Type of refrigerant used
 - m. Dimensions:
 - 1) Plan view
 - 2) Front view
 - 3) Side view
 - 4) Curb detail with dimensions
- D. Quality Assurance:
 - 1. Test Reports: Certified test reports showing compliance with specified performance characteristics and physical properties.
 - 2. Certificates: Product certificates signed by manufacturer certifying materials comply with specified performance characteristics and criteria and physical requirements.
 - 3. Manufacturer's Instructions: Manufacturer's installation instructions
- E. Closeout Submittals: Submit following:
 - 1. Warranty: Warranty documents specified
 - 2. Operation and Maintenance Data:
 - a. Operation and maintenance data
 - 1) Include methods for maintaining installed products
 - 2) Precautions against cleaning materials
 - 3) Methods detrimental to finishes and performance
 - 4) Include names and addresses of spare part suppliers
 - 3. Provide brief description of unit
 - 4. Provide
 - a. Equipment inspection report
 - 1) Equipment operation test report
 - 5. Commissioning Report: Submit commissioning reports, report forms and schematics in accordance with Section 01810 - Commissioning.

PART 1.05 QUALITY ASSURANCE

- A. Qualifications:
 - 1. Installer experienced in performing work of this section who has specialized in installation of work similar to that required for this project.
 - 2. Manufacturer Qualifications: Manufacturer capable of providing field service representation during construction and approving application method.

GUIDE SPECIFICATIONS

Specifier Note: Paragraph below should list obligations for compliance with specific code requirements particular to this section. General statements to comply with a particular code are typically addressed in Conditions of the Contract and Division 1 Regulatory Requirements Section. Repetitive statements should be avoided. Current data on building code requirements and product compliance may be obtained from filter manufacturer technical support specialists

- B. Pre-installation Meetings:
 - 1. To verify project requirements
 - 2. Follow Manufacturer's installation instructions
 - 3. Adhere to manufacturer's warranty requirements
 - 4. Comply with Division 1 Project Management and Coordination

PART 1.06 DELIVERY, STORAGE & HANDLING

- A. General: Comply with Division 1 Product Requirements
- B. Ordering: Comply with manufacturer's ordering instructions and lead-time requirements to avoid construction delays
- C. Packing, Shipping, Handling and Delivery
 - 1. Deliver materials in manufacturer's original, unopened, undamaged containers with identification labels intact
 - 2. Ship, handle and unload units according to manufacturer's instructions
- D. Storage and Protection:
 - 1. Store materials protected from exposure to harmful weather conditions
 - 2. Factory shipping covers to remain in place until installation

PART 1.07 PROJECT CONDITIONS

- A. Installation location: **[Confirm design conditions and temperature.]**

Specifier Note: Coordinate article below with Conditions of the Contract and with Division 1 Closeout Submittals (Warranty).

PART 1.08 WARRANTY

- A. Project Warranty: Refer to Conditions of the Contract for project warranty provisions
- B. Warranty:
 - 1. Commencing on Date of Installation
 - 2. Aluminized Heat Exchangers: 10 years (limited) (non-residential applications)
 - 3. Stainless Steel Heat Exchangers: 15 years (limited) (non-residential applications)
 - 4. Compressors: 5 years (limited) (non-residential applications)
 - 5. Integrated Modular Controller (IMC): 3 years (limited) (non-residential applications)
 - 6. Other System Components: 1 year (limited) (non-residential applications)

GUIDE SPECIFICATIONS

PART 2 PRODUCTS

Specifier Note: Retain article below for proprietary method specification. Add product attributes, performance characteristics, material standards and descriptions as applicable. Use of such phrases as "or equal" or "or approved equal" or similar phrases may cause ambiguity in specifications. Such phrases require verification (procedural, legal and regulatory) and assignment of responsibility for determining "or equal" products.

PART 2.01 PACKAGED ROOFTOP UNITS

- A. Manufacturer: *[Lennox Industries Inc.]*
 - 1. Contact: *[2100 Lake Park Blvd., Richardson, TX 75080; Telephone: (800) 453-6669; website: www.lennox.com Products/Systems: *[Lennox' SG and SC high efficiency]* Packaged Rooftop Unit (RTU).]*
- B. *[Proprietary]*
- C. Manufacturer is to do all the following at the factory:
 - 1. Run test units before shipping
 - 2. Assemble units
 - 3. Wire and pipe units
 - 4. Install *[IMC]* unit controller
- D. Information plate:
 - 1. Material can be any of the following:
 - a. Stamped metal plate
 - 1) Polyester with an overlay product to protect from fading
 - 2) Mylar with an overlay product to protect from fading
 - 2. Located on outside of unit
 - 3. Information on the plate shall contain:
 - a. Name of manufacturer
 - 1) Serial number
- E. Plastic or rubber bushings to be used wherever wiring runs through sheet metal
- F. RTU's to include the following equipment:
 - 1. Cabinet:
 - a. Interior panels:
 - 1) 18 or 20 ga. thickness
 - 2) G-90 Galvanized steel
 - b. Exterior panels:
 - 1) Heavy gauge
 - 2) G90 Galvanized steel
 - 3) Two layer, pre-painted baked enamel finish
 - 4) Corrosion resistant paint
 - a) Salt spray resistance of 1,000 hours, ASTM B117
 - b) Adhesion: ASTM D3359
 - c) Impact resistance: ASTM 2794
 - d) Humidity resistance: ASTM 2247
 - e) Abrasion resistance: ASTM 4060
 - f) Flexibility: ASTM D522 (NCCAI-19)
 - g) Pencil hardness: ASTM D3363 (H-2H)
 - c. Base rails:
 - 1) Full perimeter
 - 2) Gauge:
 - a) 3 and 5 ton shall be 14 gauge
 - b) 10 and 20 ton shall be 12 gauge
 - 3) G-90 Galvanized steel
 - 4) Unpainted
 - 5) To have rigging holes on all 4 corners
 - 6) Shall have forklift slots: on at least 2 sides
 - a) 3 and 5 ton shall have slots on 2 sides
 - b) 10 and 20 ton shall have slots on 3 sides

GUIDE SPECIFICATIONS

- d. Vertical supply and return airflow configuration
- e. Access Panels:
 - 1) Hinged:
 - a) Full length within 1" of door length
 - b) Piano style
 - 2) Include tie-backs or prop rods on panels or Prop Rods!!
 - 3) Air/water seals
 - 4) Quarter-turn latching handles
 - a) Factory supplied
 - b) Field installed
 - 5) Provide access to:
 - a) Economizer/filter section
 - b) Blower section
 - c) Compressors/control/heat section
- f. Condenser section access panel:
 - 1) Hinged
 - 2) 12" X 12" panel size, minimum
- g. Openings:
 - 1) Unit base access for electrical **[and gas]** lines
 - 2) Horizontal access knockouts for electrical **[and gas]** lines
 - 3) 1" Raised edges around duct and power entry openings
 - 4) Base pan:
 - a) One piece for 3, 5 and 10 ton units
 - b) Three piece base pan for 20 ton unit
- h. Insulation:
 - 1) Panels adjacent to conditioned air insulated with non-hygroscopic fiberglass insulation
 - 2) Unit base fully insulated
 - 3) To serve as air seal to the roof curb
- i. Grille guards between outdoor coils and main cabinet
- j. **[Cabinet option: Condenser coil corrosion protection]**
 - 1) **Polymeric epoxy coating**
 - a) **Electrocoat process**
 - b) **Pre-painted corrosion protection on blower assembly**
 - c) **Pre-painted corrosion protection on evaporator base assembly**
 - d) **Pre-painted corrosion protection on blower support walls**
 - e) **Factory installed]**
- k. **[Cabinet option: Evaporator coil corrosion protection]**
 - 1) **Polymeric epoxy coating**
 - a) **Electrocoat process**
 - b) **Factory installed]**

GUIDE SPECIFICATIONS

2. Cooling System:
 - a. Operating range of 0 degrees F - 125 degrees F (-18 - 52 degrees C) with **[IMC unit controller]**
 - b. Refrigerant:
 - 1) R-410A
 - 2) Factory charged
 - c. Compressors:
 - 1) Scroll Type
 - 2) Rubber grommet vibration isolation
 - 3) Thermostatically controlled crankcase heaters
 - 4) High pressure switch
 - 5) Low pressure switch
 - 6) To be located in separate compartment, not in airflow
 - 7) Compressor Controls
 - a) For 3 phase units, minimum compressor on time of 240 seconds (60-510 seconds adjustable)
 - b) For 1 phase units, minimum compressor off time of 300 seconds (60-510 adjustable)
 - c) Compressors:
 - (1) Lock out setpoint at 55 F (13 C)
 - (2) Outdoor air temperature (adjustable from -30 F (-34 C) to 80 F (27 C).
 - d) High pressure controls lock out compressors and activate digital output for service if high pressure switch trips 3 times during one cooling or dehumidification cycle (1-8 times adjustable). Record error, nonvolatile memory.
 - e) Low pressure controls lock out compressors and activate digital output for service if low pressure switch trips 3 times during one cooling or dehumidification cycle (1-8 times adjustable). Record error, nonvolatile memory.
 - f) Freezestats shut off compressors if freezestat trip occurs.
 - g) Freezestats lock out compressors if freezestat trip occurs 3 times during cooling demand (1-4 times adjustable)
 - d. Thermal expansion valves with removable element head
 - e. Filter/driers
 - 1) Solid core
 - a) Molecular sieve liquid line
 - b) To be located in condenser compartment
 - c) Easily accessible for replacement
 - f. Freezestats
 - g. Coil Construction:
 - 1) Factory leak tested
 - 2) Copper tube construction
 - 3) Rippled-edge aluminum fins
 - 4) Flared shoulder tubing connections
 - 5) Silver solder
 - h. Evaporator Coil:
 - 1) Face-split (constant air volume)
 - 2) Row-split (variable air volume)
 - 3) Cross flow circuiting
 - 4) Rifled copper tubing
 - i. Condenser Coils:
 - 1) Slab design
 - a) No Channel to sit on
 - j. Outdoor Coil Fan Motors:
 - 1) Thermal overload protection
 - 2) Totally enclosed
 - 3) Permanently lubricated ball bearings
 - 4) Shaft up
 - 5) Wire basket mount
 - k. PVC coated outdoor coil fan guard, factory supplied
 - l. Condensate Drain Pan:
 - 1) Galvanized steel
 - 2) Painted
 - 3) 2" minimum depth
 - 4) Width to be approximately 2" wider than coil
 - 5) 1/8" pitch toward drain opening
 - 6) Drain connection
 - a) Extends outside unit, but no more than 1"
 - b) NPT threads with factory installed cap

GUIDE SPECIFICATIONS

3. Heating System:
 - a. Gas:
 - 1) Type: **[Natural gas] [and]/[or] [Liquid propane (LPG)]**
 - 2) Aluminized steel inshot burners
 - 3) Direct-spark ignition
 - 4) Electronic flame sensor
 - 5) Combustion air inducer
 - 6) Redundant gas valve:
 - a) Automatic
 - b) Single or dual stage
 - c) Manual shutoff
 - 7) Heat Exchanger:
 - a) Aluminized steel and/or **[stainless steel]**
 - b) Dimple-design
 - c) Life cycle tested
 - d) Tubular design
 - e) Factory installed
 - 8) Limit Controls:
 - a) Factory installed
 - b) Fixed temperature setting
 - 9) Safety Switches:
 - a) Manual flame rollout switch
 - b) Flame sensor and combustion air inducer proving switch
 - c) Monitored by **[IMC unit controller]**
 - 10) Controls:
 - a) Turn supply fan on 40 seconds after heating demand is received (8-60 seconds adjustable)
 - b) Turn off supply fan 120 seconds after heating demand has ended (80-300 second adjustable)
 - c) 30 second time delay between 1st and 2nd stage (low and high) fire gas valve system (30-160 second adjustable)
 - d) Stop gas heat 100 seconds after thermostat heating demand has ended (30-300 seconds adjustable)
 - e) Turn off heat and keep supply fan running if overheat limit occurs
 - f) Turn off unit after overheat limit trips 3 times in one heating cycle (1-15 trips adjustable)
 - g) Report overheat limit error, stored in nonvolatile memory
 - h) Turn off unit if flame rollout occurs. Requires manual reset. Report error, stored in nonvolatile memory
 - i) Turn off heat if induced airflow pressure is too low. Report error, stored in nonvolatile memory
 - j) Turn off unit if low induced airflow pressure trips 3 times during one heating cycle (1-6 trips adjustable)
 - k) Report gas valve not energized 2 minutes after heating demand fault. Identify specific gas valve (if multiple)
 - l) Turn off gas valve if flame not sensed. Report error, stored in nonvolatile memory
 - m) Turn off unit if gas valve is energized with no demand for heat. Report error, stored in nonvolatile memory
 - 11) **[Fresh air tempering kit:**
 - a) **Field installed**
 - b) **Supply air temperature sensor}**

GUIDE SPECIFICATIONS

- b. Electric:
 - 1) Helix wound nichrome elements
 - 2) Time delay for element staging
 - 3) Individual element limit controls
 - 4) Wiring harness
 - 5) May be four-stage controlled in zone sensor mode
 - 6) Controls:
 - a) Turn off supply fan 20 seconds after heating demand has ended (0-300 seconds adjustable)
 - b) Time delay of 12 seconds between 1st and 2nd stage heat (low and high), (12-60 second adjustable)
 - c) Turn off heat and keep supply fan running if overheat limit occurs
 - d) Turn off unit if overheat limit trips 3 times during one thermostat cycle (1-15 trips adjustable)
 - e) Generate error code if overheat limit trips, stored in nonvolatile memory
- 4. Indoor Air Quality:
 - a. Air filters
 - 1) Disposable
 - 2) MERV 7
 - a) 2 inch
 - b) 14 pleats per foot
 - b. Filter rack to be adjustable (2" to 4")
 - c. **[CO₂ sensor:**
 - 1) **Factory supplied**
 - 2) **Shipped separate**
 - 3) **Field installed]**
- 5. Blower:
 - a. Motor:
 - 1) Overload protected
 - 2) Ball bearings
 - b. Supply Air Blower
 - 1) Forward curved blades
 - 2) Blower wheel to be statically and dynamically balanced
 - 3) Constant air volume applications will use adjustable pulleys
 - a) Available on 3, 5, 10 and 20 ton units
 - b) Adjustable pulleys to set airflow
 - 4) Multi-stage air volume applications:
 - a) Available on 10 and 20 ton units
 - b) Use a variable frequency drive (VFD) to control fan speed
 - c) Change fan speed according to mode of operation (cooling operation according to number of compressors in operation, heating operation, ventilation operation and smoke detector mode)
 - d) Customizable fan speeds per each mode of operation (through the IMC)
 - e) 10 ton features five separate supply fan speeds (compressor number one operation, compressor number two operation, gas or electric heat, ventilation operation and smoke detector mode)
 - f) 20 ton features seven separate supply fan speeds (compressor number one operation, compressor number two operation, compressor number three operation, compressor number four operation, gas or electric heat, ventilation operation and smoke detector mode)

GUIDE SPECIFICATIONS

- c. Controls:
 - 1) Turn on blower 0 seconds after cooling demand has been received (0-60 seconds adjustable)
 - a) Turn off blower 0 seconds after cooling demand has ended (0-240 seconds adjustable)
- d. Ground and polished shafts
- 6. Integrated Modular Controller (IMC) unit controller:
 - a. Solid-state microprocessor control board
 - b. 24V control voltage
 - c. Transformer with built in circuit protection
 - d. Control modes:
 - 1) Capable of controlling unit operation via third party device (thermostat or DDC)
 - 2) Capable of controlling unit operation via Integrated Modular Controller and unit sensors
 - e. Display, diagnostics and configuration
 - 1) Control parameters
 - a) 200 control parameters
 - b) Field changeable
 - c) Built in factory defaults
 - d) Customizable delays, cooling stages, heating stages, deadbands and setpoints
 - 2) Unit diagnostics
 - a) 100 diagnostic codes
 - b) Codes stored through power failure
 - 3) User interface
 - a) Three digit display
 - b) Push button and DIP switch allows changes in the field
 - c) LED display to indicate control system transmit and receive
 - d) LED display to indicate thermostat input status
 - 4) Displays the following:
 - a) Control parameters
 - b) Diagnostic codes
 - c) Unit temperature sensor information (return air, supply air, outdoor air)
 - d) Remote temperature sensor information (CO₂, temperature, relative humidity)
 - 5) Network capable
 - a) Daisy chained to other IMC equipped units or L Connection Network controllers
 - b) Requires twisted wire pair
 - f. Safety, reliability and serviceability
 - 1) Strike three protection
 - a) Ends unit operation due to critical alarms
 - b) Terminates operation after three alarms during a single thermostat cycle
 - c) Number of alarms that will trigger unit shut down is adjustable at IMC
 - d) Critical alarms include low pressure trip, high pressure trip, heat limit trip or freeze stat trip
 - 2) Smoke alarm mode
 - a) Eight smoke alarm choices
 - b) Unit off
 - c) Blower on, exhaust fan off, outdoor air damper open (positive pressure)
 - d) Blower on, exhaust fan on, outdoor air damper closed (negative pressure)
 - e) Blower on, exhaust fan on, outdoor air damper open (purge)
 - f) Blower off, exhaust fan on, outdoor air damper closed (negative pressure)
 - g) Blower on, exhaust fan on, outdoor air damper closed (negative pressure)
 - h) Blower on, exhaust fan on, outdoor air damper open (purge)
 - i) Blower off, exhaust fan on, outdoor air damper closed (negative pressure)
 - 3) Minimum compressor run time
 - 4) Thermostat bounce delay
 - 5) Safety switch input
 - a) Normally closed digital input that will respond to an external safety switch trip
 - b) Will shut down unit operation
 - 6) Low ambient control down to 0 F
 - 7) Service relay output
 - a) Digital output that can communicate to external device when an error occurs
 - b) Can be configured to operate based on relative humidity, indoor air quality, outdoor air temperature, unit operation

GUIDE SPECIFICATIONS

- g. Comfort, efficiency and indoor air quality
 - 1) Staging
 - a) Up to 2 heat and 2 cool in thermostat mode
 - (1) 3 ton = 1 heat, 1 cool
 - (2) 5 ton = 1 heat (E/E), 2 heat (G/E), 1 cool
 - (3) 10 and 20 ton = 2 heat, 2 cool
 - b) Up to 4 heat and 4 cool in zone sensor mode
 - (1) 3 ton = 1 heat, 1 cool
 - (2) 5 ton = 2 heat, 1 cool
 - (3) 10 ton = 2 heat, 2 cool
 - (4) 20 ton = 4 heat, 4 cool
 - 2) Economizer control
 - a) Global input
 - b) Can lock out mechanical cooling when in economizer mode (adjustable in IMC)
 - c) Will modulate to 55 F supply air temperature during economizer only operation (adjustable in IMC)
 - 3) Fresh air tempering
 - a) Provides heating and cooling as necessary to maintain the supply air temperature within a comfort range
 - b) Operates when there is no thermostat demand for heating or cooling
 - c) Requires field installed sensor
 - 4) Warm-up mode delay
 - a) Keeps the economize damper closed during morning warm up
 - b) Adjustable time through IMC
 - 5) Indoor air quality input
 - a) Provides demand control ventilation capability
 - b) Two operation modes:
 - (1) Setpoint mode: opens the economizer dampers to set position when CO2 setpoint level is reached
 - (2) Proportional mode: opens the economizer dampers at the first setpoint and gradually increase it as the Co2 level increases until the second setpoint is reached
 - 6) Exhaust fan control
 - 7) Load shedding
 - 8) Night setback mode
 - 9) Return air temperature limit control
 - 10) Gas valve time delay between first and second stage
- h. **[Factory installed option: Smoke Detector**
 - 1) **Option of either supply, return or both**
 - 2) **Photo-electric type**
 - 3) **Requires 115v external power source]**
- i. **[Factory option or field installed accessory**
 - 1) **Novar ETM 2024**
 - 2) **Danfoss RTC**
 - 3) **CPC Multiflex 810-3062]**

GUIDE SPECIFICATIONS

- j. System integration:
 - 1) Direct integration to third party control systems
 - 2) Allows third party control system to access diagnostic information and most commonly used setpoints and control information
 - 3) Rooftop unit direct integration to Novar Lingo(R) or Savvy(R) systems
 - a) Integrated through IMC
 - b) Requires use of Logic One System Enhancer (LSE), furnished by Novar
 - 4) Rooftop unit direct integration to CPC Einstein E2BX panel
 - a) Integrated through IMC
 - b) Requires software furnished by CPC requires use of Logic One System Enhancer (LSE), furnished by Novar
- 7. Electrical:
 - a. Single point connection
 - b. Circuit Breakers:
 - 1) HACR type
 - 2) Factory wired and mounted
 - 3) Current sensitive
 - 4) Temperature activated
 - 5) Manual reset
 - 6) Use wire ties to keep wires grouped together
 - 7) All relays, timers, contactors need to be located in one compartment
 - 8) Electric heat contactors located in electric heat compartment, if selected
 - c. GFI Service Outlets:
 - 1) Factory installed
 - 2) 115 V ground fault circuit interrupter
- 8. Serviceability:
 - a. **[IMC unit controller diagnostic codes]**
 - b. Refrigerant circuits to be marked and color coded
 - c. Electrical plugs for common accessories
 - d. Common parts throughout tonnage range
 - e. Compressors to be near perimeter of the unit
 - f. Do not need to remove top panel to replace any components (except damaged cabinet parts)
 - g. Do not need to remove to clean coil, condensate pan or blower assembly
 - h. All external and internal screws in the cabinet structure and component mounting screws shall have a 5/16" hex head
- 9. **[Economizer/Outdoor Air, Factory Installed Options:]**
 - a. **[Economizer:**
 - 1) Parallel gear driven
 - 2) Plug in connections to unit
 - 3) Nylon bearings
 - 4) Neoprene seals
 - 5) 24 V fully modulating spring return motor
 - 6) Adjustable minimum damper position, 0% - 100%
 - 7) Slides into RTU
 - 8) To utilize a jack plug
 - 9) Includes outdoor air hood accessory
 - 10) Includes barometric relief damper accessory
 - 11) **IMC unit controller add-on board for economizer control]**
 - b. **[Barometric Relief Dampers:**
 - 1) Factory installed
 - 2) Bird screen
 - 3) Hood included]
 - c. **[Outdoor Air Damper Section:**
 - 1) Linked mechanical slide damper
 - 2) Factory installed
 - 3) Hood included
 - 4) Adjustable minimum position, 0% - 25%]
 - d. **[Power Exhaust Fan:**
 - 1) Available for 10 and 20 ton models only
 - 2) Internal or external
 - 3) Requires Economizer
 - 4) Motor is overload protected
 - 5) Hood included]

GUIDE SPECIFICATIONS

Specifier Note: Edit Article below to suit project requirements. If substitutions are permitted, edit text below. Add text to refer to Division 1 Project Requirements (Product Substitutions Procedures) Section.

PART 2.02 PRODUCT SUBSTITUTIONS

- A. Substitutions: No substitutions permitted.

PART 3 EXECUTION

PART 3.01 MANUFACTURER'S INSTRUCTIONS

Specifier Note: Article below is an addition to the CSI *SectionFormat* and a supplement to MANU-SPEC. Revise article below to suit project requirements and specifier's practice.

- A. Compliance: Comply with manufacturer's written data, including product technical bulletins, product catalog installation instructions, product carton installation instructions and [Lennox Industries Inc.] SPEC-DATA® sheets.

PART 3.02 EXAMINATION

- A. Site Verification of Conditions: Verify substrate conditions, which have been previously installed under other sections, are acceptable for product installation in accordance with manufacturer's instructions.

PART 3.03 INSTALLATION

- A. Install **[Packaged rooftop units]** in accordance with manufacturer's instructions **[On roof curbs] [provided by manufacturer] [as indicated]**.



ARI Standard
210/240 UAC



ARI Standard
340/360



VERIFIED
ENERGY
PERFORMANCE



VERIFIE
RENDEMENT
ENERGETIQUE



Visit us at www.lennox.com
For the latest technical information,
www.lennoxcommercial.com
Contact us at 1-800-4-LENNOX

NOTE - Due to Lennox' ongoing commitment to quality, Specifications, Ratings and Dimensions subject to change without notice and without incurring liability. Improper installation, adjustment, alteration, service or maintenance can cause property damage or personal injury. Installation and service must be performed by a qualified installer and servicing agency.

©2007 Lennox Industries Inc.

ROOFTOP UNIT SCHEDULE (LENNOX SG SERIES)

MARK	AREA SERVED	NOMINAL CAPACITY (TONS)	SUPPLY FAN				GAS HEAT INPUT (MBH)	ECONOMIZER TYPE	SMOKE DETECTOR LOCATION	NOTES
			CFM	ESP	OUTSIDE AIR CFM	OPERATION				
1	DELI/PRODUCE	10	3700	0.5"	370	AUTO	130	FME	RA	
2	GROCERY ENTRY	10	3700	0.5"	370	AUTO	240	FME	RA	
3	FOOD TENANT KITCHEN	5	1650	0.5"	165	AUTO	125	FME	---	B
4	FOOD TENANT SEATING	5	1650	0.5"	165	AUTO	125	FME	---	A,B
5	TENANT	5	1650	0.5"	165	AUTO	125	FME	---	
6	TENANT	5	1650	0.5"	165	AUTO	125	FME	---	
7	FRONT OFFICES/RESTROOMS	3	1200	0.5"	120	AUTO	75	FME	---	
8	OPTICAL EXAM	3	1200	0.5"	120	AUTO	75	FME	---	B
9	OPTICAL SALES	3	1200	0.5"	120	AUTO	75	FME	---	
10	GM ENTRY	10	3700	0.5"	370	AUTO	240	FME	RA	
11	COURTESY/PHOTO LAB	5	1650	0.5"	165	AUTO	125	FME	---	
12	CHECKOUT	20	9000	0.25"	0	AUTO	480	FME	RA	A
13	CHECKOUT	20	9000	0.25"	0	AUTO	480	FME	RA	
14	SALES	20	9000	0.25"	0	AUTO	480	FME	RA	A
15	BAKERY	10	3700	0.5"	370	AUTO	130	FME	RA	
16	SALES	10	4500	0.25"	0	AUTO	130	FME	RA	
17	PHARMACY	3	1200	0.5"	120	AUTO	75	FME	---	
18	GR STOCK ROOM/SEAFOOD	5	1650	0.5"	165	AUTO	125	FME	---	
19	SALES	10	4500	0.25"	0	AUTO	130	FME	RA	
20	SALES	20	9000	0.25"	0	AUTO	260	FME	RA	A
21	SALES	20	9000	0.25"	0	AUTO	260	FME	RA	
22	STOCK ROOM	10	3700	0.25"	370	AUTO	240	FME	RA	
23	CORRIDOR	5	1650	0.5"	165	AUTO	125	FME	---	
24	EAKROOM/ALCOVE/RESTROO	10	3700	0.5"	370	AUTO	240	FME	RA	A
25	TRAINING/MANAGEMENT	5	1650	0.5"	165	AUTO	125	FME	---	
26	UPC	5	1650	0.5"	165	AUTO	125	FME	---	
27	RECEIVING	20	6500	0.5"	650	AUTO	480	FME	RA	
28	AUTO CENTER	10	3700	0.5"	370	AUTO	240	FME	RA	

GENERAL INFORMATION (ALL UNITS):

1. UNITS FURNISHED BY OWNER. INSTALLATION BY CONTRACTOR.
2. ALL UNITS ARE 460V, 3 PHASE, 60 HERTZ. UNITS MUST BE UL OR ETL AS WELL AS AGA APPROVED. MINIMUM AFUE = 80%.
3. UNIT OPERATING WEIGHTS (LBS): 20 TON = 3275, 10 TON = 1860, 5 TON = 1087, 3 TON = 1063.
4. OUTSIDE AIR IS CONDITIONED THROUGH THE VENTILATION UNITS FOR THE SALES FLOOR AREA AND THROUGH THE ROOFTOP UNITS AS SCHEDULED ABOVE IN ACCORDANCE WITH ASHRAE 62.1-2004.
5. SMOKE DETECTORS ARE FACTORY INSTALLED.
6. UNITS ARE PROVIDED WITH HACR-TYPE RATED CIRCUIT BREAKER.
7. UNITS ARE PROVIDED WITH SINGLE POINT POWER AND GAS ENTRY CONNECTIONS.
8. ROOF CURB FURNISHED BY OWNER. REFER TO SPECIFICATIONS.
9. UNIT ENERGY EFFICIENCY RATINGS (EER) PER ARI 210 & 360 ARE AS FOLLOWS: 3 TON = 14.3, 5 TON = 12.8, 10 TON = 12.1, 20 TON = 12.6.
10. UNITS ARE PROVIDED WITH FACTORY INSTALLED INTEGRATED MODULAR CONTROL (IMC). TEMPERATURE AND CO2 SENSORS ARE FURNISHED SEPARATELY BY LENNOX AND INSTALLED BY THE EMS CONTRACTOR.
11. MAKE FINAL COMPRESSOR WIRING TERMINATIONS ON ROTATION-SENSITIVE COMPRESSORS.
12. TPE = THREE POSITION ECONOMIZER, FME = FULLY MODULATING ECONOMIZER.
13. UNITS ARE PROVIDED WITH FACTORY INSTALLED CONVENIENCE RECEPTACLE.
14. INSTALL ANCHOR BRACKETS FURNISHED WITH ROOF CURB. REF HVAC SEISMIC/WIND RESTRAINT BRACKET DETAIL.
15. HIDE THIS ROW
15. HIDE THIS ROW

NOTES:

- A. UNIT EQUIPPED WITH RELAY FOR CO2 CONTROL, AND EXTERNALLY LABELED "IAQ" IN 3" RED LETTERS. REFERENCE EMS SHEETS. IN THE EVENT THE CO2 LEVELS RISE TO 1100 PPM, THE RTU IMC SHALL OVERRIDE THE OUTSIDE AIR DAMPER AND THE ROOFTOP UNIT ECONOMIZER SHALL MODULATE TO FULLY OPEN TO DECREASE CO2 LEVELS TO 1000 PPM. REFERENCE DEMAND BASED VENTILATION INTERPRETATION OF ASHRAE 62.1-2004.
- B. PROVIDE VERTICAL VENT EXTENSION KIT WITH VENT CAP LOCATED JUST ABOVE TOP SURFACE OF UNIT.
- C. HIDE THIS ROW

HIDE THIS ROW
HIDE THIS ROW
HIDE THIS ROW
HIDE THIS ROW

BUILDING INTERIOR

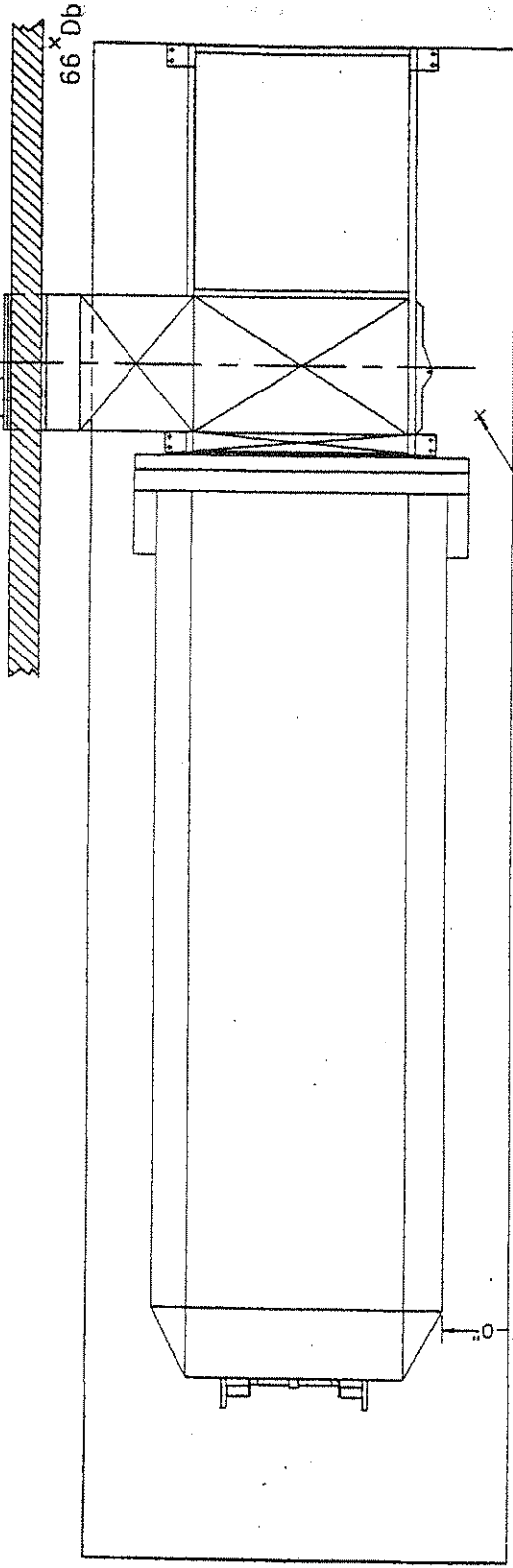

66 x Db

x 69 Db

64 Db x

x 59 Db

x 65 Db

x 60 Db

60 Db x

58 Db x

x 15'-0"

x 15'-0"

x 15'-0"

x 15'-0"

x 15'-0"

x 15'-0"

x 15'-0"

x 15'-0"

x 15'-0"

x 15'-0"

x 15'-0"

x 15'-0"

x 15'-0"

x 15'-0"

x 15'-0"

x 15'-0"

x 15'-0"

x 15'-0"

x 15'-0"

x 15'-0"

x 15'-0"

x 15'-0"

x 15'-0"

x 15'-0"

x 15'-0"

x 15'-0"

no discernable decibels on a 50 Db meter at 50

no discernable decibels on a 50 Db meter at 50

TRASH COMPACTOR OPERATION
TYPICAL SOUND LEVEL READINGS
in DECIBELS

J.V. MANUFACTURING INC. (501) 751-7320
701 HWY. 265s, P.O. BOX 229, SPRINGDALE, AR. 72765



SCALE:	DWG #:
DWN:	APPR.:
	DATE:
DESCRIPTION: CC-02 STATION ARY	

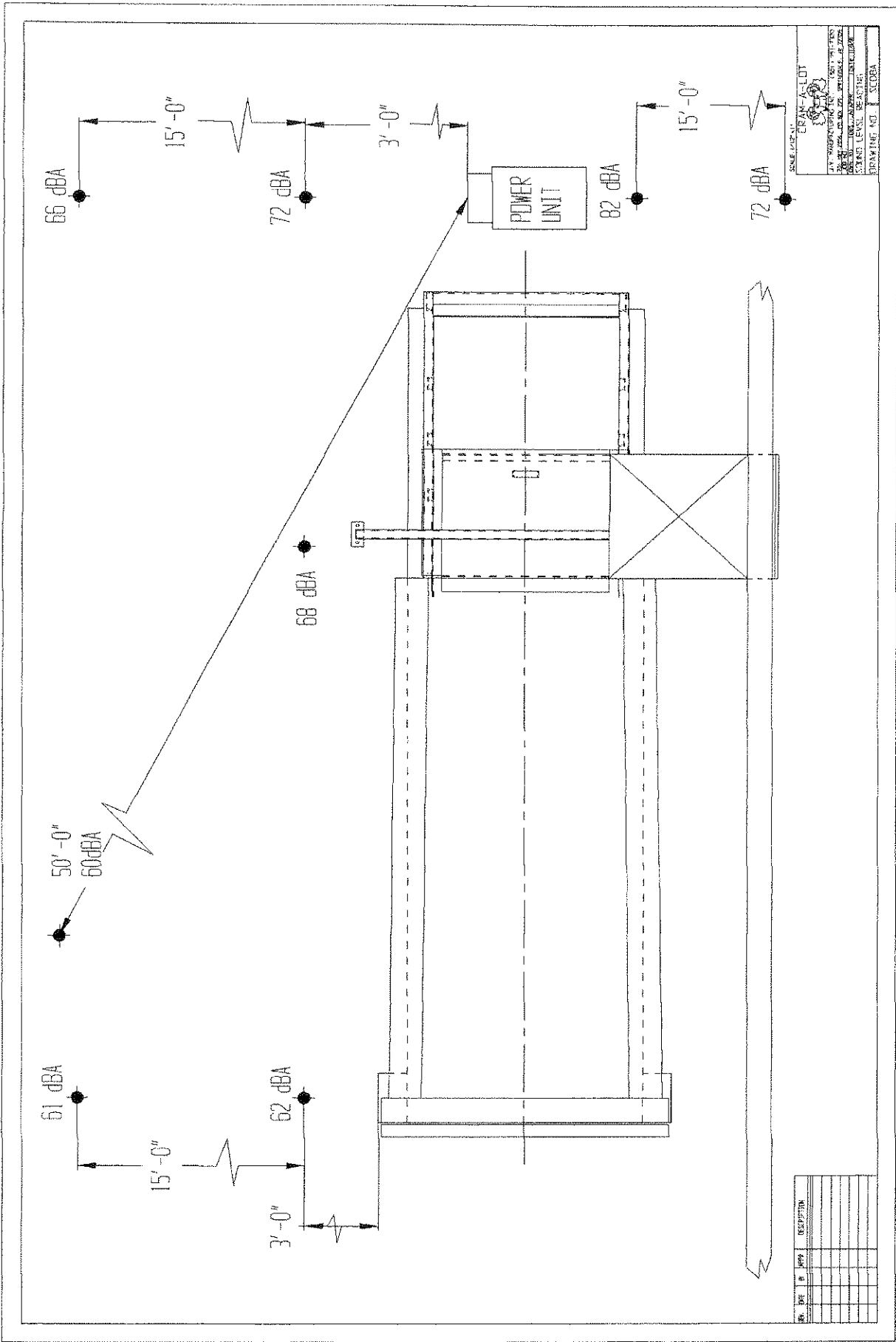

SELF-CONTAINED

b. **Location:** The baler should be located in the receiving area, in a spot where it will not interfere with receiving operations but within a reasonable distance from the DSD door. The baler should be situated a minimum of 2'-0" from the wall on the rear and 4'-0" on the hinge side (see diagram below.) Also, there should be 6'-0" of clear open floor space in front of the baler to allow for unloading the bales.

c. **Manufacturers:** The vendor which supplies the compactor for a given project will also supply the baler. The two current compactor vendors make a similar enough baler that electrically one design works for both, but in physical size there is a difference between them; for the purpose of having a single proto design which works for either vendor, the Marathon baler is to be used since it is the larger of the two.

MANUFACTURERS AND PRODUCTS

1. **Manufacturers:** Marathon Equipment Company, JV-States (Cram-a-lot).
2. **Products:** Please refer to the chart below for equipment information. This shows each manufacturers model numbers for the compactors and balers depending on proto size. The stores are divided among the two vendors by state (ref: Fig 22 for the Compactor/Baler Alignment Map.)

MARATHON EQUIPMENT				
PROTO	MODEL # (QTY) BALER	MODEL # GR. (QTY) COMPACTOR	MODEL # G.M. (QTY) COMPACTOR	
39	V6030 1	RJ-100SC 1	--	
107	V7230HD 1	RJ-100SC 1	--	
128	V7230HD 1	RJ-100SC 1	--	
134	V7230HD 1	RJ-100SC 1	--	
137	V7230HD 1	RJ-100SC 1	--	
145	V7230HD 1	RJ-100SC 1	--	
173	V7230HD 2	RJ-100SC 1	RJ225 / RJ400C 1	
192	V7230HD 2	RJ-100SC 1	RJ225 / RJ400C 1	
208	V7230HD 2	RJ-100SC 1	RJ225 / RJ400C 1	

REFER TO FIG. 22 FOR STATE LOCATIONS.

CRAM-A-LOT (JV-STATES)				
PROTO	MODEL # (QTY) BALER	MODEL # GR. (QTY) COMPACTOR	MODEL # G.M. (QTY) COMPACTOR	
39	DB-60 1	SC-02-30 1	--	
107	DB-72 1	SC-02-30 1	--	
128	DB-72 1	SC-02-30 1	--	
134	DB-72 1	SC-02-30 1	--	
137	DB-72 1	SC-02-30 1	--	
145	DB-72 1	SC-02-30 1	--	
173	DB-72 2	SC-02-30 1	CC-02 / R040 1	
192	DB-72 2	SC-02-30 1	CC-02 / R040 1	
208	DB-72 2	SC-02-30 1	CC-02 / R040 1	

REFER TO FIG. 22 FOR STATE LOCATIONS.

END OF GUIDELINE

Marathon Equipment - Truck Compactors

APPENDIX

You already know that sounds travel in waves in the air. As these waves radiate outward from their source, they cover a larger area and their strength diminishes. When the distance they travel is doubled, the amplitude of the waves is reduced by one half. For this rule to work, the first measuring point must be at least 2 or 3 times the largest dimension of the noise source, usually about 3 feet or 1 meter.

DISTANCE	SOUND STRENGTH
x	100%
2x	50%
4x	25%

As these sound waves impinge on a microphone, they produce electrical voltages that are directly proportional to the sound pressures. Keep in mind that instrumentation measuring these electrical signals are measuring the amplitude or strength of the "sound pressure" waves. This strength, and also the frequency of the waves, are the only properties of sound that are measurable, using ordinary engineering techniques.

The extensive audible range of sound complicates the problem of rating noise strength. The human ear hears, without damage, pressure levels that are about a hundred thousand times stronger than the lowest pressure level that it can detect.

Because of this, noise measuring instruments have an extraordinary range, and are conveniently scaled in decibels (dB).

Figure 1A.

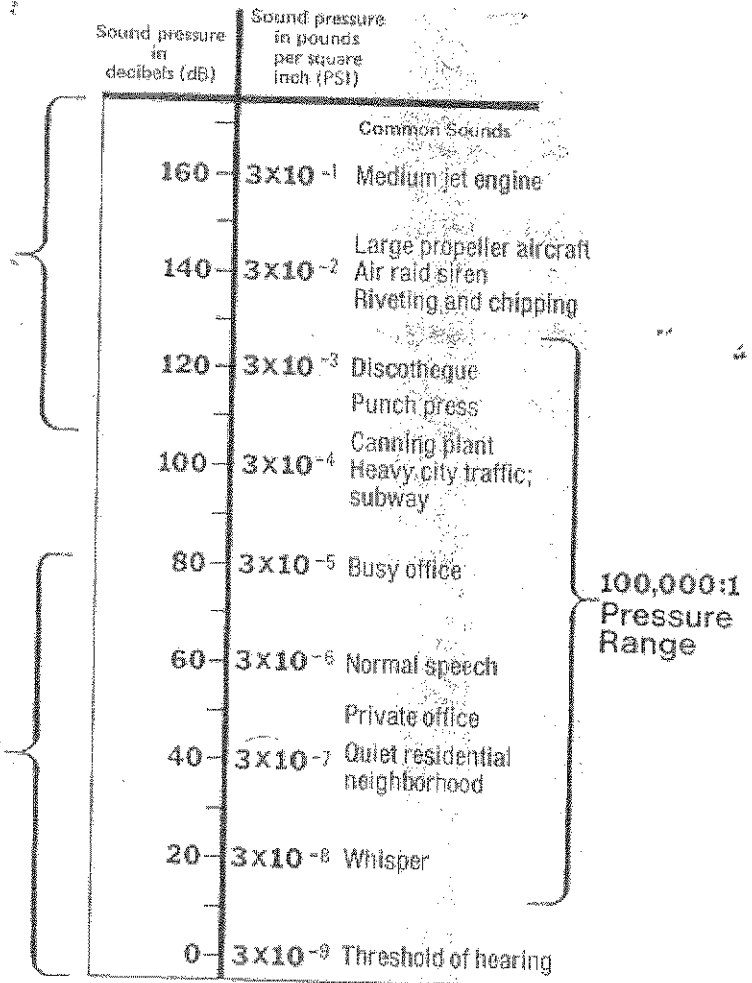
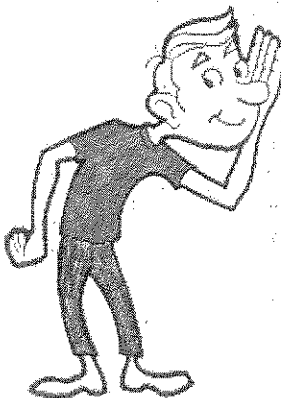

REF. No. QTY. Cat. No. Material

POINT # 4

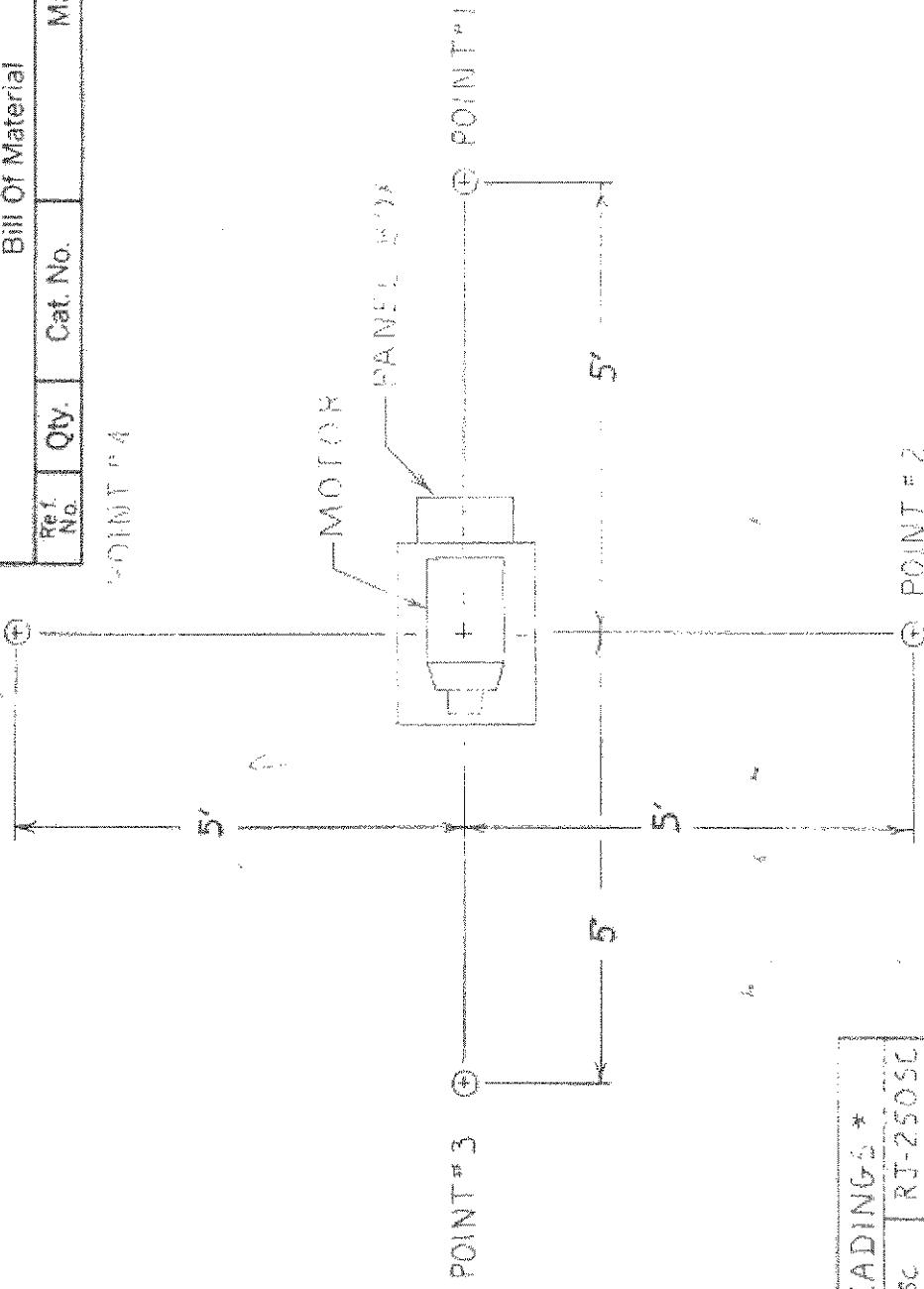

DECIBEL READINGS *	
POINT	RJ-100SC RJ-250SC
1	68
2	73
3	73
4	73

*ALL READINGS "A" WEIGHTED SLOW RESPONSE

MARRATHON
RAVJET

Equipment Company,
Vernon, Alabama 35592

Title: DECIBEL READINGS RJ-250SC
RJ-100SC POWER UNIT

Drawn: RB

Date: 1-5-69

Drawing Number: 31-45711

SHEET: _____

OF _____

Routing:

Scale: N.T.S.

Tolerances: