

District 301
WO# 95576

BLACK HILLS POWER AND LIGHT COMPANY
Application and Agreement for Electric Service Extension
State of South Dakota

Contract Number _____
Effective Date _____

The "Company" Black Hills Power and Light Company and the "Applicant"

Applicant: **City of Rapid City**
 Address: **300 6th Street** City: **Rapid City, SD** Zip: **57701**

Agree as follows:

- (1) The Company will install and furnish electric service for the Customer for the Leachate & Remediation Project @ the Rapid City Landfill located in the SE¼ Section 19, T1N, R8E, BHM, Pennington County, SD in accordance with rates and extension rules on file with the South Dakota Public Utilities Commission.
- (2) The Applicant agrees to accept service under the following rate schedule **10** or if eliminated the most economical and applicable remaining rate schedule for a period of not less that forty-eight (48) months from the date of initial service. The Annual Revenue from service to the Applicant as determined under Section 800 Line Extensions of the Company's Tariffs is **\$100.00** resulting in a Line Extension Allowance of **\$400.00** of Company financed facilities (cost estimate attached).

 If it is determined at any time subsequent to the execution of this Application that the Applicant has changed the nature of his/her electrical service, the Line Extension Allowance shall be adjusted accordingly, which may result in a charge to the Applicant, if the construction costs exceed the correct Line Extension Allowance.
- (3) If applicable, the Applicant agrees to pay the Company prior to construction of facilities:
 - a) A refundable Advance Deposit subject to the rules filed by the Company for the cost of extending electric facilities beyond the Line Extension Allowance determined at (2) above. **\$11,594.00**
- (4) The Applicant shall, without cost to the Company, make or procure satisfactory conveyance to Company of right-of-way for Company's lines necessary and incidental to the furnishing of service to customer and for continuing, upgrading or extending said lines over and across the property owned or controlled by Applicant.
- (5) The Applicant shall, without cost to the Company, furnish a cleared right-of-way, and also grants to the Company for maintenance purposes, the right, as the Company may see fit, to cut, trim, or remove from said right-of-way any brush, trees, stumps, or roots.

- (6) For underground line extensions and service laterals the Applicant will provide all trenching to the Company specifications, washed sand, or approved bedding, conduit when required, backfill, or any other restoration work required.
- (7) The Applicant will be entitled to refunds of the Advance Deposit under two (2) separate and distinct calculations:

a) The applicant may be entitled to a refund of all or part of any Advance Deposit required under paragraph (3) if additional extensions are constructed from the electric facilities requested herein. Only those line extensions which connect directly with the facilities partially financed by the Applicant, without any intervening line extensions will be considered when determining the Applicant's entitlement for a refund. The refund will be equal to the difference between the applicable Line Extension Allowance for the new applicant and the estimated construction cost of the additional electric facilities. The Applicant will receive any applicable refund within thirty (30) days of the Applicant contacting the Company regarding the construction of additional electric facilities. The refunded advance deposit shall not bear interest.

(b)The Applicant may be entitled to a refund of all or part of any Advance Deposit required under paragraph (3) if the actual revenue from the Applicant's account(s) served during the first four (4) years as a result of this application exceeds the Line Extension allowance. The refunded advance deposit shall bear simple interest at the rate of seven (7) percent annually.

Refunds will be made only to the Applicant if still receiving service at the same location. Eligibility for refunds under a) above is limited to four (4) years from the effective date of this agreement. Eligibility for refunds under b) above is determined four (4) years from the effective date of this agreement. In no case shall the total refund to the Applicant exceed the amount of the Advance Deposit. Any Advance Deposit not refunded to the Applicant as set forth above shall be retained and become the property of the Company.

- (8) The refundable Advance Deposit or any portion thereof shall not be assignable by the Applicant. Payments of such refundable Advance Deposit shall continue to be made when due to the Applicant notwithstanding a transfer of the place to which electric service was extended.

Applicant

ATTEST:

Black Hills Power INC

Accepted by:

Mayor

Finance Officer

Date _____

Date

Date _____

Copies: Applicant, Property, G.O.,
Contract File, District Office

Prepared By: Mark Lemery
Black Hills Power, Inc.
PO Box 1400
Rapid City, SD
(605) 721-2235

WO# 95576

RIGHT-OF-WAY PERMIT - OH/UG CORPORATION

We, **City of Rapid City**, in consideration of the sum of \$1.00, receipt of which is hereby acknowledged, hereby grants to BLACK HILLS POWER, INC. having its principal place of business and post office address at 625 Ninth Street, P.O. Box 1400, Rapid City, South Dakota 57709, its successors and assigns, a perpetual right-of-way and easement to construct, operate and maintain, repair, alter, inspect, remove, upgrade, enhance and replace an electrical power system consisting of buried cables or wires, surface terminals, surface markers, transformer pads or vaults, and an electrical power line with poles, wires and associated equipment, and all necessary attachments and appurtenances, with the right of ingress and egress therefor, together with the power to extend to any communications company the right to use any pole or trench placed pursuant to the provisions hereof, upon, over and across that certain piece of real estate hereinafter described, together with the right to cut, trim, or remove from said right-of-way any brush, trees, stumps, or roots where necessary to secure a clearance from the conductors of at least **10** feet on each side of the center line of said right-of-way. This easement shall run with the land. The centerline of the powerline as constructed is the center line of the easement.

The real estate above referred to is specifically described as follows: **SEE EXHIBIT "A"**

The foregoing right is granted upon the express condition that Black Hills Power, Inc. will assume liability for all damage to the hereinbefore described property caused by said Black Hills Power, Inc. failure to use due care in its exercise of the granted right.

Dated this ____ day of _____, 20___. [Corporate Seal]

Signed: _____

Signed: _____

STATE OF: _____ COUNTY OF: _____

On this ____ day of _____, 20____, before me, the undersigned officer, personally appeared _____ and _____, who acknowledged themselves to be the _____ and _____, respectively, of the **City of Rapid City** a Corporation, and at that they as such officers, being authorized so to do, executed the foregoing instrument for the purposes therein contained, by signing the name of the Corporation by themselves as such officers.

IN WITNESS WHEREOF, I hereunto set my hand and official seal.

Notary Public

My Commission Expires

(Seal)

EXHIBIT "A"

The real estate referred to is specifically described as follows:

**Tract A Wasteland Subdivision
Located in the SE¼ Section 19,
T1N, R8E, B.H.M., Pennington
County, South Dakota**

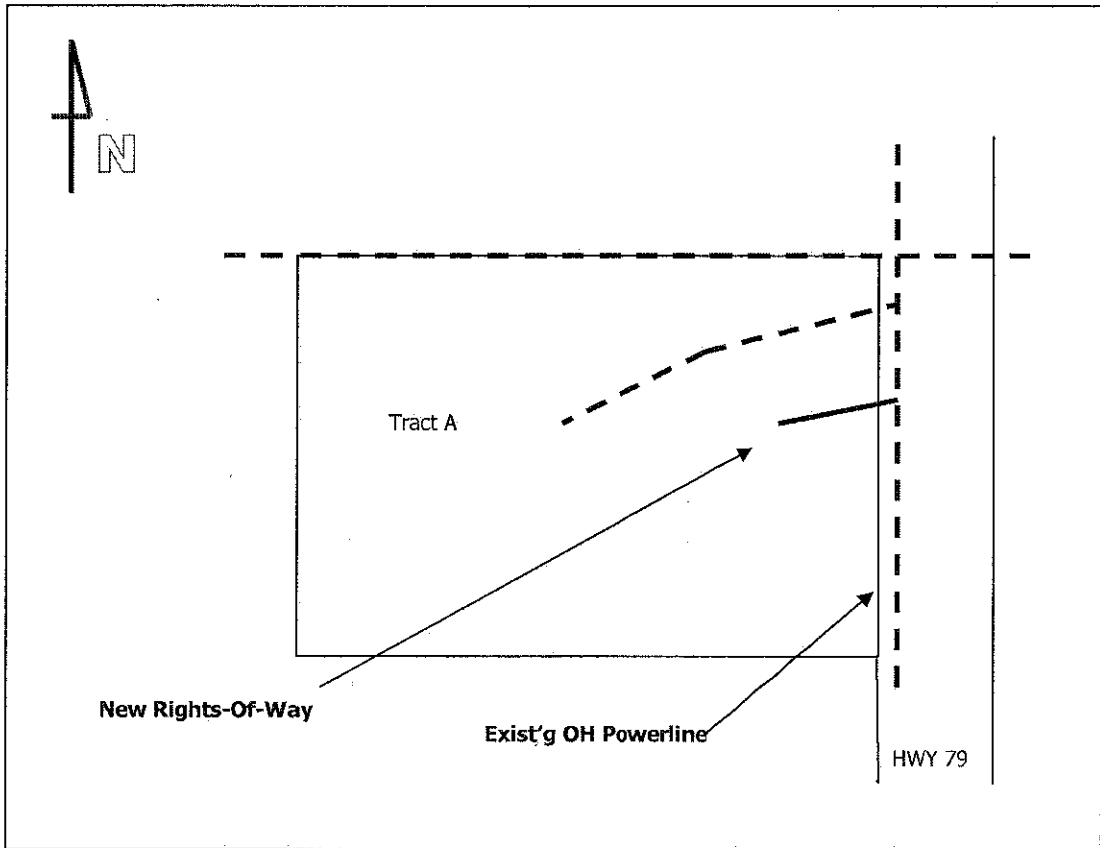

NOTE: The centerline of the powerline as constructed is the center line of the easement.



GRADE AGREEMENT

This Agreement made the _____ day of _____, 20____ between Black Hills Power, hereinafter called the Utility, and City of Rapid City, hereinafter called the Developer, witnesseth:

The Utility will locate its equipment, and facilities in the areas requested and designated by the Developer on the land being developed by Developer as shown on the Map or Plat of RC Landfill Leachate Removal & Remediation Project which Map or Plat is hereby attached to and made a part of this Agreement. The Developer shall furnish to the Utility the final elevations and grades, which final elevations and grades shall be accurate to ± 6 inches (final elevations and grades, are interpreted to mean, all work necessary prior to acceptance by homeowner). In addition, the Developer shall advise the Utility prior to commencing any excavations or grades after Utility facilities have been constructed, Developer will pay at its sole expense all costs of raising, lowering, relocating, or otherwise rearranging, repairing, or changing such facilities when in the opinion of the Utility such work is necessary to provide required clearances, stability and protection of structures or underground facilities in accordance with the applicable building or construction codes, and policies of the Utility. In the event that the Developer or any independent contractor of the Developer has not complied with the terms and conditions of this Agreement, and if damage to any existing Utility facilities occurs, the Developer shall pay all damages and loss suffered by the Utility in repairing, relocating, or replacing such facilities, including a reasonable attorney's fee.

The Developer will establish a sufficient number of lot corners when requested by Utility in or that the Utility facilities may be placed in its proper location with respect to easement, street, or alley lines, and other utilities.

In witness whereof the aforesaid parties have hereunto by their authorized representatives set their hands and seals on the day and year first above written.

Witness or Attest:

Black Hills Power
By: _____

Developer

By: _____



Mark Lemery
 Construction Representative
 Mark.Lemery@blackhillscorp.com

P.O. Box 1400
 Rapid City, SD 57709
 P: 605.721-2235
 F: 605.721.2574

Nov. 13, 2009

Commercial OH-ug Service

Dan Coon, PE
 City of Rapid City
 300 6th Street
 Rapid City, SD 57701

RE: New electrical service to Landfill Leachate Removal & Remediation Project

Dear Mr. Coon

This letter is to follow-up with Randy Hanson's request to update the BHP costs for the above project. Considering the information Randy provided, we are planning to serve the 277/480V, 3Ø, 4-wire, **200 Amp** main with an overhead main line with an underground service. My understanding is that the service meter location will be on a meter pedestal adjacent to the Proposed Vault.

Black Hills Power will provide and install the following:

- Overhead primary power line (poles, conductors, and transformer)
- Underground service conductors from our pole mounted transformer to your meter location
- Self-contained Meter

The owner/contractor will be responsible for the following:

- Provide all legal desc & names (Deeds) and Plats for all property w/ proposed powerline routes.
- Customer is responsible for all gov't/city permits of proposed electric utility facilities for this proj
- Provide all completed original Right-Of-Way documents with landowner's signatures Notarized.
- Make Line Extension refundable advanced deposit payment (see below).
- Return the sign "Agreement for Electric Service Extension" 4-year contract (see attachment).
- Return the signed Grading Agreement Affidavit (see attachment).
- All lot lines, corner pins, utility easements field surveyed & staked by a certified Land Surveyor.
- All tree removal/ trimming (*remove debris and re-seed scarred ground to condition originally found*).
- Provide vehicle access to all pole locations.
- Provide all trenching/ sand bedding/ Backfill (*after finished grading has been establish*)(see constr det).
- Provide and install all conduits under streets/ driveways with a spare (see attached for size & locations).
- Provide and install self contained "bypass" 200A meter socket.
- Provide and install the meter pedestal (see construction details)
- Provide me with the size of your service wire (i.e. - 2 sets of #500 MCM Cu)
- BHP may require compensating starters for motors above 10hp & BHP must give written approval.

RECEIVED

NOV 13 2009

ENGINEERING DIVISION

New electrical service to Landfill Leachate Removal & Remediation Project
Nov. 13, 2009
Page 2

Considering the estimated allowance (4-year revenue) for this project (\$400– Based on the type of business, **Rate 20**), less the BHP cost to provide service (\$11,994 - WOES), **there is an \$11,594 cost**, for this line extension. Please see the attached Agreement for Electric Service Extension for terms.

I understand that this is a preliminary design and cost estimate. If the routing has to be changed due to ROW/ permitting, owner preference, or if the owners design changes, BHP will need to refigure this cost estimate. This cost estimate is good for six months from the date of this letter. Please review the enclosed information and feel free to contact me if you have any questions about the service arrangements or when you are ready to move forward with construction.

Sincerely,

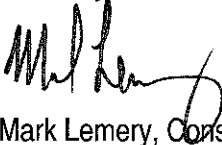

Mark Lemery, Construction Representative

ENCL: Map w/ Constr. Standards, Service Extension Contract, Right-Of-Ways, & Grade Agreement
Please copy your contractor w/ the Map & Construction Standards

cc: Randy Hanson, Associate
Wenck Associates, Inc
3310 Fiechtner Dr, Suite 110
Fargo, ND 58103



Commercial OH-ug Service

CHECKLIST

DESIGN - Black Hills Power will provide the following:

- Design Route Map & Construction Details (See Attachments)

DESIGN - The Owner will be responsible for the following:

- Provide all legal desc & names (Deeds) and Plats for all property with proposed powerline routing.
- Provide all completed original Right-Of-Way documents with landowner's signatures Notarized.
- Customer is responsible for all gov't/city permits for prop electric utility facilities for this proj.
- Make Line Extension refundable advanced deposit payments (Make check out to Black Hills Power).
- Return the sign "Agreement for Electric Service Extension" 4-year contract.
- Return the signed Grading Agreement Affidavit (see attachment).

Pre-CONSTRUCTION - The Owner/Contractor will be responsible for the following:

- Have all lot lines, corner pins & utility easements field surveyed/ staked by a certified Surveyor
- All tree removal/ trimming (*remove debris and re-seed scarred ground to condition originally found*)
- Provide vehicle access to all pole locations
- Provide all trenching/ sand bedding/ Backfill (*after finished grading has been establish*)(see constr det)
- Provide and install all conduits under streets/ driveways with a spare (see attached for size & locations)
- Provide and install self contained "bypass" 200A meter socket
- Provide me with the size of your service wire (i.e. - 2 sets of #500 MCM Cu)
- Provide a soft motor starter for all motors over 10hp (if required)

CONSTRUCTION - Black Hills Power will provide and install the following:

- Overhead primary power line (poles, conductors, and transformer)
- Underground service conductors from our pole mounted transformer to your meter socket
- Self-contained Meter

Please give your contractors a copy of this Check List, Route Map, and all Construction Details so they can coordinate final arrangements during construction.

Tract A Wasteland Subd

Located in the SE1/4 of Section 19 T1N, R8E, BHM

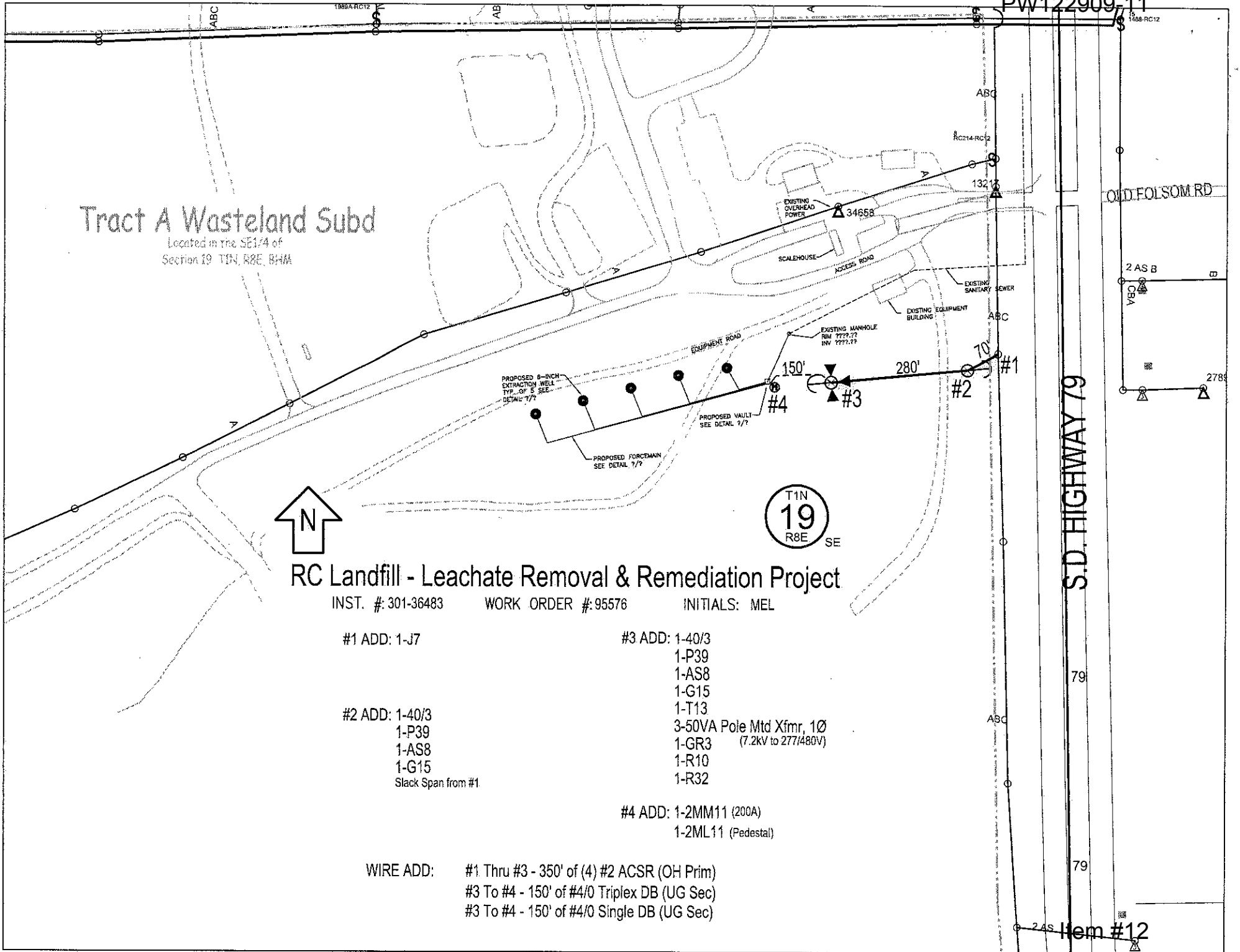

RC Landfill - Leachate Removal & Remediation Project

INST. #: 301-36483

WORK ORDER #: 95576

INITIALS: MEL

#1 ADD: 1-J7

#2 ADD: 1-40/3

- 1-P39
- 1-AS8
- 1-G15
- Slack Span from #1

#3 ADD: 1-40/3

- 1-P39
- 1-AS8
- 1-G15
- 1-T13
- 3-50VA Pole Mtd Xfmr, 1Ø
(7.2kV to 277/480V)
- 1-GR3
- 1-R10
- 1-R32

#4 ADD: 1-2MM11 (200A)

1-2ML11 (Pedestal)

WIRE ADD:

- #1 Thru #3 - 350' of (4) #2 ACSR (OH Prim)
- #3 To #4 - 150' of #4/0 Triplex DB (UG Sec)
- #3 To #4 - 150' of #4/0 Single DB (UG Sec)

S.D. HIGHWAY 79

OLD FOLSOM RD

79

79

2 AS Item #12

Vacinity Map



Rapid City

**JOB
SITE**

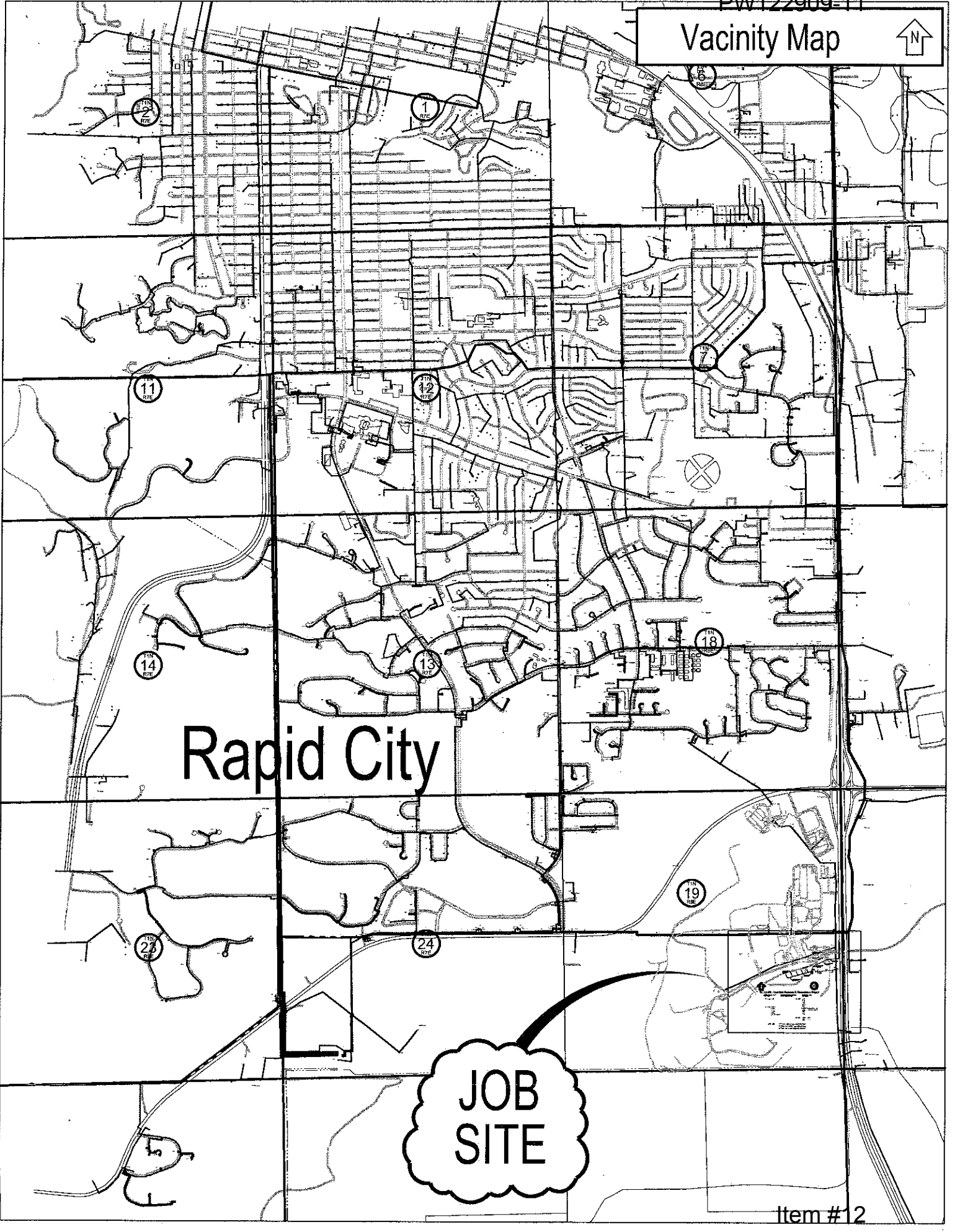

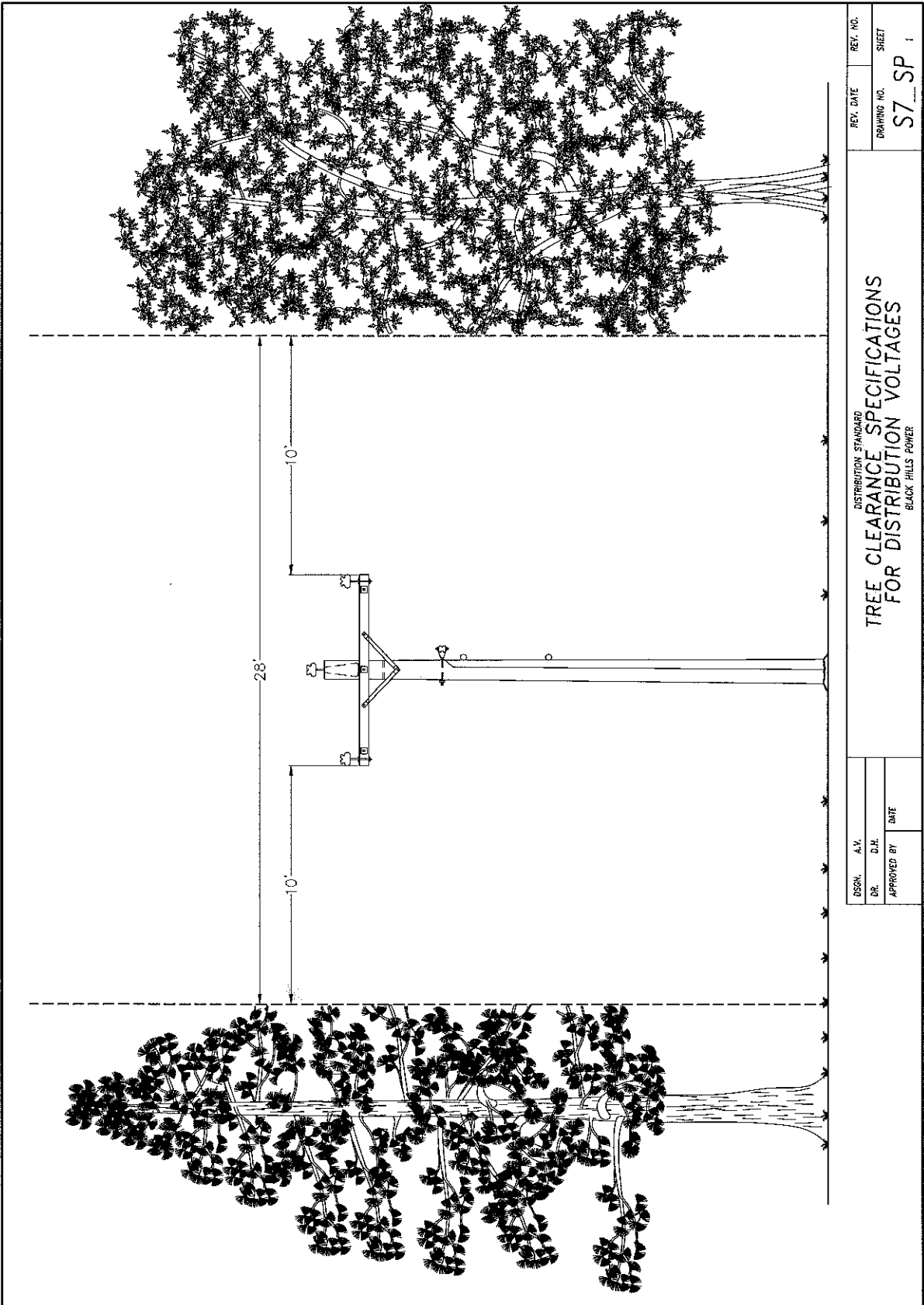

DISTRIB. STANDARD		REV. DATE	REV. NO.
TREE CLEARANCE SPECIFICATIONS FOR DISTRIBUTION VOLTAGES		DRAWING NO.	SHEET
BLACK HILLS POWER		S7 SP 1	
DESIGN. A.V.	DR. D.H.	APPROVED BY	DATE

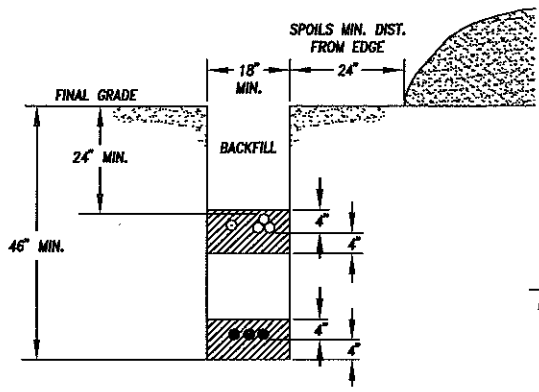

TR1
 SINGLE PHASE PRIMARY
 THREE PHASE PRIMARY
 SECONDARY SERVICE
 PHONE & TV

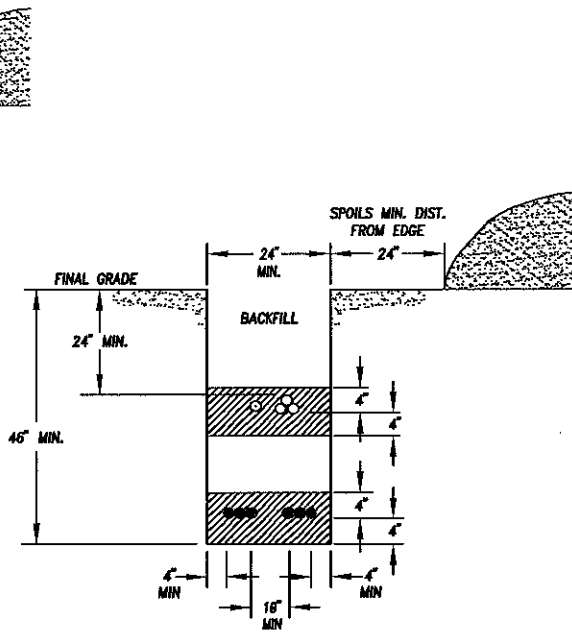

TR3
 THREE PHASE PRIMARY LOOPED
 (6 PRIMARY WIRES IN DITCH)

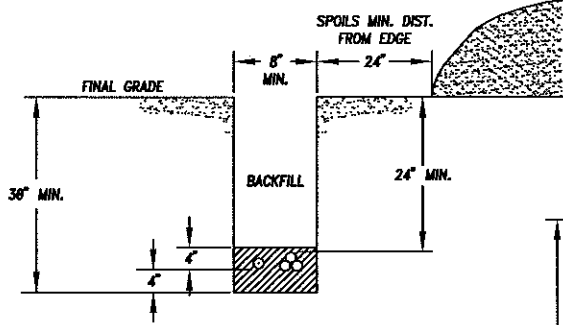

TR2
 SECONDARY SERVICE
 PHONE & TV

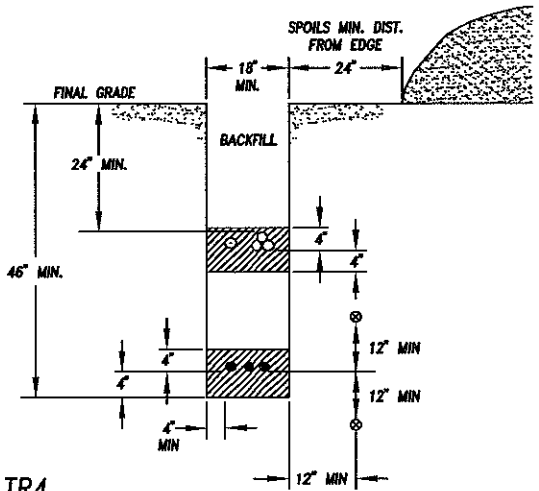

TR4
 JOINT USE - WATER OR SEWER

LEGEND:

- PRIMARY CABLE
- ⊗ SECONDARY CABLE
- PHONE & TV
- ⊙ WATER OR SEWER
- ⊕ GAS LINE

SAND BACKFILL - MINIMUM OF 4" ON ALL SIDES (NO CRUSHED ROCK OR FINES)

TRENCH DEPTHS AS SHOWN ARE "MINIMUMS";
 "MAXIMUM" DEPTHS NOT TO EXCEED MINIMUMS BY MORE THAN 6".

NOTE: HORIZONTAL DISTANCE FROM FACILITIES TO WATER OR SEWER MUST BE 48" MINIMUM WITHIN THE PLANNING JURISDICTION OF RAPID CITY.

DSGN. TM	DISTRIBUTION STANDARD TRENCH SPECIFICATIONS WITHOUT GAS BLACK HILLS POWER	REV. DATE 4/1/97	REV. NO. 4
DR. JLM/DCL		DRAWING NO. TR1, TR2	SHEET
APPROVED BY DATE		TR3, TR4	1

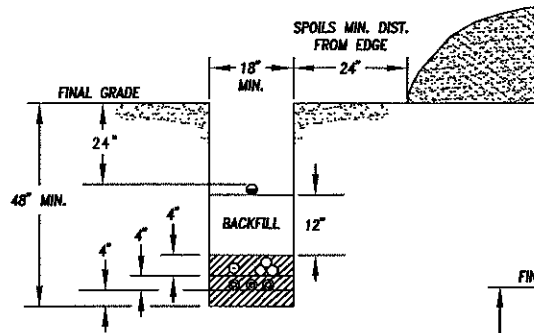

TR5
 SINGLE PHASE PRIMARY
 THREE PHASE PRIMARY
 SECONDARY SERVICE
 PHONE, TV & GAS

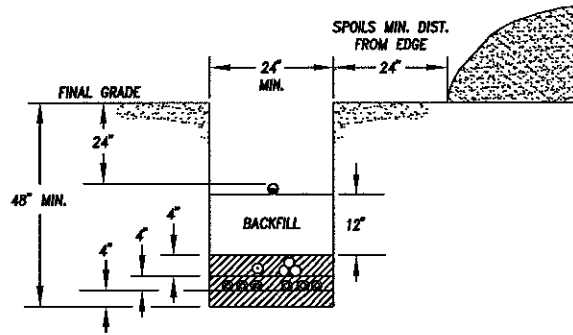

TR7
 THREE PHASE PRIMARY LOOPED
 (6 PRIMARY WIRES IN DITCH)

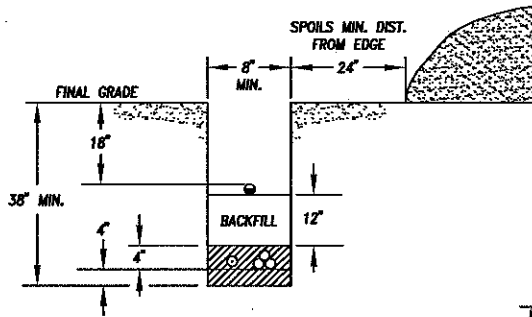

TR6
 SECONDARY SERVICE
 PHONE, TV & GAS

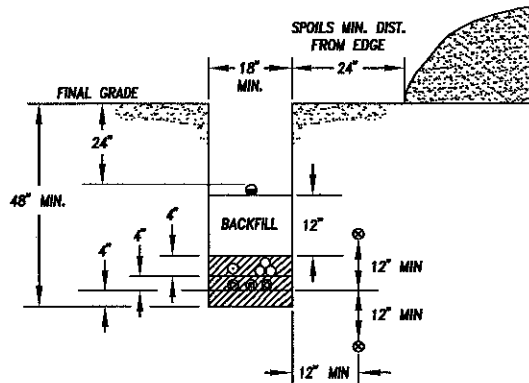

TR8
 JOINT USE - WATER OR SEWER
 NOTE: HORIZONTAL DISTANCE FROM FACILITIES TO WATER OR SEWER MUST BE 48" MINIMUM WITHIN THE PLANNING JURISDICTION OF RAPID CITY.

LEGEND:

- ⊙ PRIMARY CABLE
- ⊗ SECONDARY CABLE
- ⊙ PHONE & TV
- ⊙ WATER OR SEWER
- ⊙ GAS LINE
- SAND BACKFILL - MINIMUM OF 4" ON ALL SIDES (NO CRUSHED ROCK OR FINES)

TRENCH DEPTHS AS SHOWN ARE "MINIMUMS";
 "MAXIMUM" DEPTHS NOT TO EXCEED MINIMUMS BY MORE THAN 6".

DSGN. TM	DISTRIBUTION STANDARD TRENCH SPECIFICATIONS JOINT WITH GAS BLACK HILLS POWER	REV. DATE 4/1/97	REV. NO. 3
DR. JLM/DCL		DRAWING NO. TR5, TR6 TR7, TR8	SHEET 1
APPROVED BY	DATE		



Definitions:

1. Electric utilities include power, lighting, telephone, cable t.v., signal circuits, etc.
2. Non-electric utilities include water, gas, sewer, storm drains, etc.
3. Sand bedding or back fill does not include fines, crushed rock or "blow sand". Fine aggregate for concrete (natural sand) per ASTM Designation C-33, par.. 5.1 and 5.3, "Grading", is the only approved bedding material. Deviation from the natural sand bedding can only be authorized by the Customer Service department.

Trench:

1. Clearances must be obtained from all other buried utilities before digging.
2. The cable trench should be located two feet, minimum off the property line.
3. The cable trench must meet the specifications of Standard Drawings TR1, TR2, TR3 or TR4.
4. Where the surface grade of the trench location is not final, steps must be taken to insure minimum standard depth subsequent to installation.
 - a. If the grade is to be lowered, the depth of cut must be added to our standard trench depths.
 - b. If the grade is to be raised, the trench must be standard depth at the time it is dug.
 - c. Curb and gutter must be installed in subdivisions prior to trenching to insure proper grade.
5. Back fill or bedding within 4 inches of cable or conduit systems shall be free of all rocks or other materials that may damage the cable. Sand bedding as in "definitions" above is the only standard approved material for this "cushion" around the cable or conduit.
6. Back fill must be adequately tamped or packed to prevent sinking and meet the specifications of governmental agencies when necessary. Machine compaction must not be used within 6 inches of the cable or conduit to prevent damage.

Conduit:

1. At crossings of cables and non-electric utilities, the cable should be protected by installing it in a short section of conduit projecting a minimum of 4 feet both ways from the crossing. Conduit shall be PVC schedule 40 electrical conduit.
2. A spare conduit shall be placed adjacent to all 600 volt or primary cables crossing under driveways, streets or paved parking lots.
 - a. Two inch conduit shall be used for single phase primary.
 - b. Four inch conduit shall be used for three phase primary and service cables.
 - c. Two single phase services will fit a 4 inch conduit.
3. Some situations will require the cable to be pulled in conduit and the use of primary or secondary pull boxes. This method will normally be used only when short sections of trench can be opened at one time.
4. Conduit risers shall be installed in accordance with PVC molded riser drawings.

Safety:

1. Before working on primary wire, be sure there is a visible open at both ends and it is grounded, unless insulated sticks are used.
2. All enclosures, transformers and switching modules must be kept locked at all times except when actually working at their location.
3. Any termination bushing points in any apparatus not in use must have an approved insulating cap in place. (Dust covers are NOT approved insulating caps)

Cable Installations:

1. Cable will not be placed in a trench unless it meets the the standard trench specification including the appropriate bedding.
2. Cable will be inspected as it is installed to insure no kinks, cuts, abrasions or damage of any kind.
3. Cable must be placed in the trench loosely, with adequate slack, and resting on the bottom of the trench for its entire length.
4. Be sure sufficient lengths of cable are left at the ends for risers and or terminations.
5. Cable paralleling non-electric utilities or other subsurface structures shall not be installed directly above or below such utilities. See Trench Specifications #TR4 for minimum spacings.
6. Trench will be inspected prior to cable installation and prior to back filling, by Black Hills Power and Light Company personnel.
7. Cable ends must be sealed when exposed if termination or splice is to be done at a later time. This will prevent moisture migration into the cable.

DSGN. J.R.N.	DISTRIBUTION STANDARD URD CABLE AND TRENCH GUIDELINES BLACK HILLS POWER	REV. DATE 4/1/97	REV. NO. 3
DR. J.H./D.C.L.		DRAWING NO. U1	
APPROVED BY		DATE	1 of 2

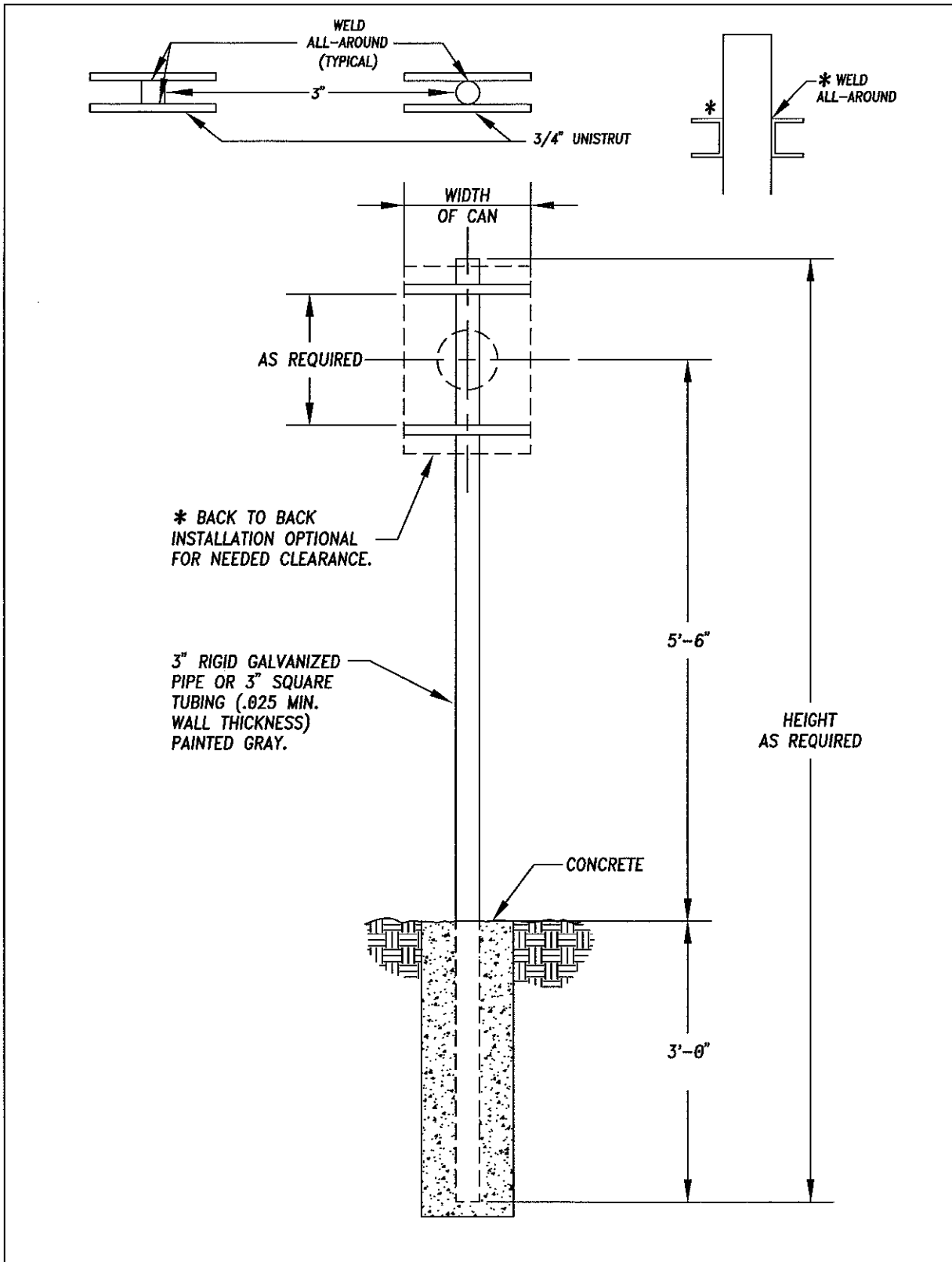

DSGN. P.K.	DISTRIBUTION STANDARD	REV. DATE	REV. NO.
DR. C.E.I./D.C.L.		4/15/88	2
APPROVED BY	SELF CONTAINED METERING PEDESTAL FOR PERMANENT UNDERGROUND SERVICES	DRAWING NO.	SHEET
DATE		M13	1
		BLACK HILLS POWER	



1. The customer is urged to make early contact with BHP&L for permanent service.
2. An affidavit or city inspection must be obtained before service can be provided.
3. Permanent services must be located where the meter will be protected from mechanical injury. Should relocation of a permanent service become necessary, the relocation cost will be the responsibility of the Customer.
4. Overhead permanent service drops shall be supported on BHP&L approved pole, wall, or structure. The maximum service drop length from BHP&L's pole to the service depends upon conductor size. Consult with your BHP&L Representative to determine the maximum distance. Permanent service must meet BHP&L Co. standards.
5. Customer owned metering equipment, switching devices, conduits, conductors, luminaries, etc., are not to be mounted on BHP&L's poles.
6. 3 foot minimum working space required between electrical meter and any other obstruction attached to the building.
7. Customer has responsibility to provide and maintain a 3 foot clearance from all tree limbs for the electrical overhead service from the pole to the service attachment on the customers building or dwelling.
8. When practical, equipment or other obstructions shall maintain a minimum clearance of 10 feet away from a BHP pole. This includes items such as temporary service pedestals or poles, meter pedestals, communication pedestal, padmount transformers, fences, etc..
9. Grounding requirements:
 - A. Ground wire -- No. 6 copper minimum -- in separate conduit not in with BHP&L wire..
 - B. Ground rods -- 8' long -- 5/8" ground rod, as per latest issue of N.E.C.
 - C. All ground rods to be installed in undisturbed earth.
 - D. All ground rods to be embedded below permanent moisture level per N.E.C. 250-83.
10. Metering requirements: (Meter furnished by BHP&L)
 - A. All meter cans to be ring-less, not ring type.
 - B. Any commercial use must have bypass handle.
 - C. All UG meter cans must be at least 200 amp as per BHP&L standards and installed level in all directions.
 - D. All OH meter cans must be at least 100 amp as per BHP&L standards and installed level in all directions.
 - E. Meter cans to conform with BHP&L meter bulletin.
 - F. Line side hookup on UG meter cans to be done by BHP&L.
 - G. All meters to be outside of buildings -- not inside.
 - H. Meter location must be on the side or front of structures for underground. On the side or rear for overhead. (Side for overhead preferred)
 - I. If self contained meter can is not attached to a building, a service disconnect will be required on the load side or adjacent to the meter can. Both disconnect and wire on the load side will be customer owned.
11. No LB elbows on line side conduit allowed, all corners shall be of the sweep variety.
12. Customer owned guying, when required, to be adequate for wire size and span lengths. See your BHP&L representative for recommendations.
13. Underground services must be covered or back filled before service may be energized.
14. Service addresses shall be clearly marked and posted on the structure or on the meter cans when multi meter banks are installed.

DSGN.	D.D. / M.W.	PERMANENT SERVICE REQUIREMENTS FOR PERMANENT ELECTRIC SERVICE BLACK HILLS POWER	REV DATE	REV NO.
DR.	K.M./D.C.L.		5/01/07	6
APPROVED BY	DATE		DRAWING NUMBER SV1	



1. The customer is urged to make early contact with BHP&L for temporary service.
2. The customer is required to pay a standard fee for temporary service. When special construction is required there will be additional charges.
3. An affidavit or city inspection must be obtained before service can be provided.
4. In addition to installation and removal charges, the customer will be required to pay a service charge for each metered connection.
5. Temporary services for construction work must be located where the meter will be protected from mechanical injury and, when practical, a location should be selected that would be usable throughout the construction period. Should relocation of a temporary service become necessary the relocation cost will be the responsibility of the Customer.
6. Overhead temporary service drops shall be supported on BHP&L approved pole or timber and shall be furnished and installed by the Customer. The maximum service drop length from BHP&L's pole to the service depends upon conductor size. Consult with your BHP&L Representative to determine the maximum distance. Temporary service must meet BHP&L Co. standards.
7. Customer-owned metering equipment, switching devices, conduits, conductors, luminaires, etc., are not to be mounted on BHP&L's poles.
8. Customer owned guying, when required, to be adequate for wire size and span lengths. See your BHP&L representative for recommendations.
9. All underground temporary meter loops will be located at the transformer or at the secondary service wire at the lot line. Any variation to this standard; see your BHP&L Representative for recommendations.

DSGN.	D.G./D.D.	TEMPORARY SERVICE REQUIREMENTS FOR TEMPORARY ELECTRIC SERVICE / CONSTRUCTION POWER BLACK HILLS POWER	REV. DATE	REV. NO.
DR.	K.M./D.C.L.		7/94	9
APPROVED BY	DATE		DRAWING NUMBER SV6	

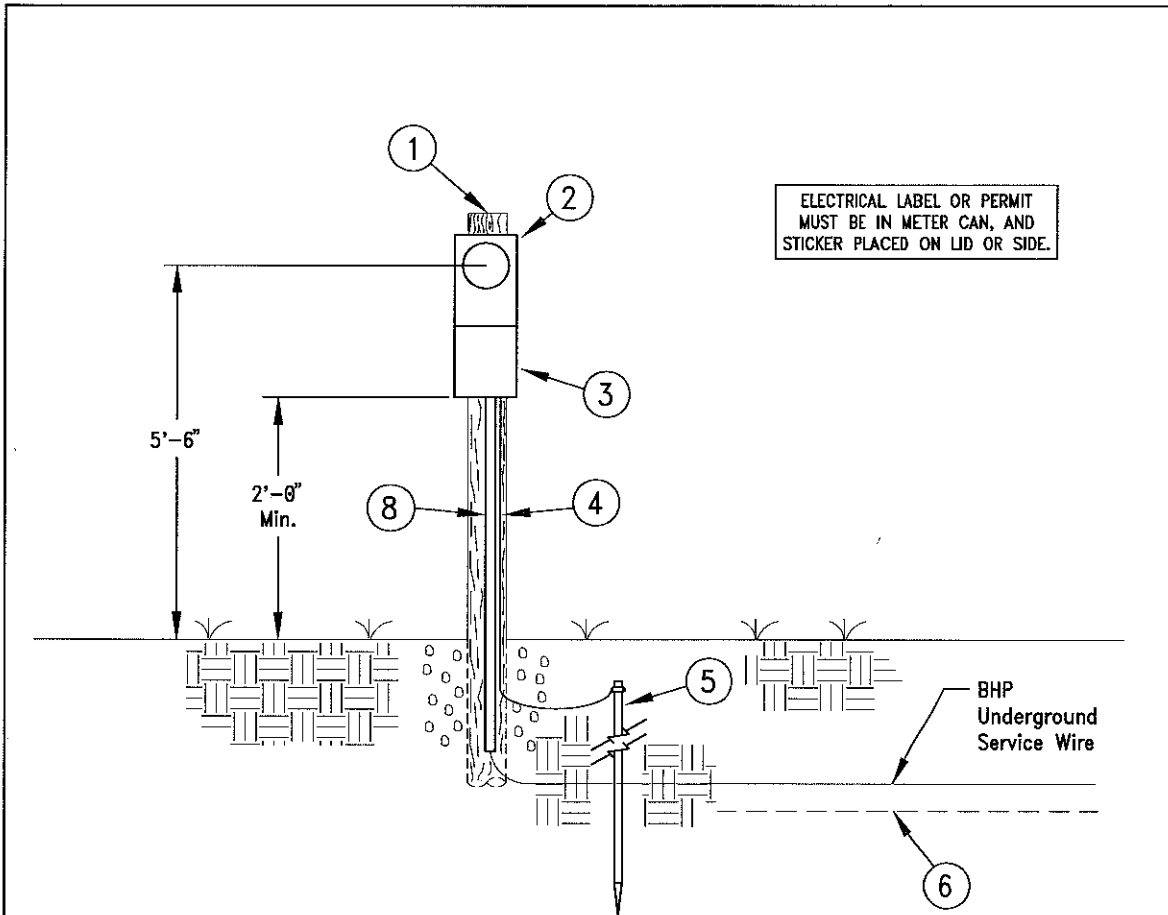

ELECTRICAL LABEL OR PERMIT
MUST BE IN METER CAN, AND
STICKER PLACED ON LID OR SIDE.

NOTES:

1. Pressure treated 5" x 7" wood post, owned by customer, to be buried 36" in ground.
2. Meter can must be BHP approved and installed level in all directions, Ringless Type.
3. Customer disconnect equipment -- weather tight -- minimum capacity 30 amperes. Switch box must be covered when inspected.
4. Ground wire -- No. 6 copper Minimum.
5. Ground rod -- 8' long -- 5/8" ground rod. NOTE: ground rod is not required if temp. service is adjacent to pad mount transformer where ground lead is provided from BHP transformer.
6. Trench according to BHP specifications.
7. Temporary service charges must be paid and a permit for temporary service or a wiring affidavit approving the service for connection must be obtained before service can be provided.
8. 2" PVC electrical conduit to a depth 12" in ground and conductor with 24" tail out of conduit: provided by customer
9. Underground service line must be covered or back filled before service may be energized.
10. See SV1 for any other requirements.

DSGN.	D.G. / D.D.	TEMPORARY SERVICE UNDERGROUND TEMPORARY SERVICE BLACK HILLS POWER	REV DATE	REV NO.
DR.	K.M./D.C.L.		1/87	2
APPROVED BY	DATE		DRAWING NUMBER SV6.2	

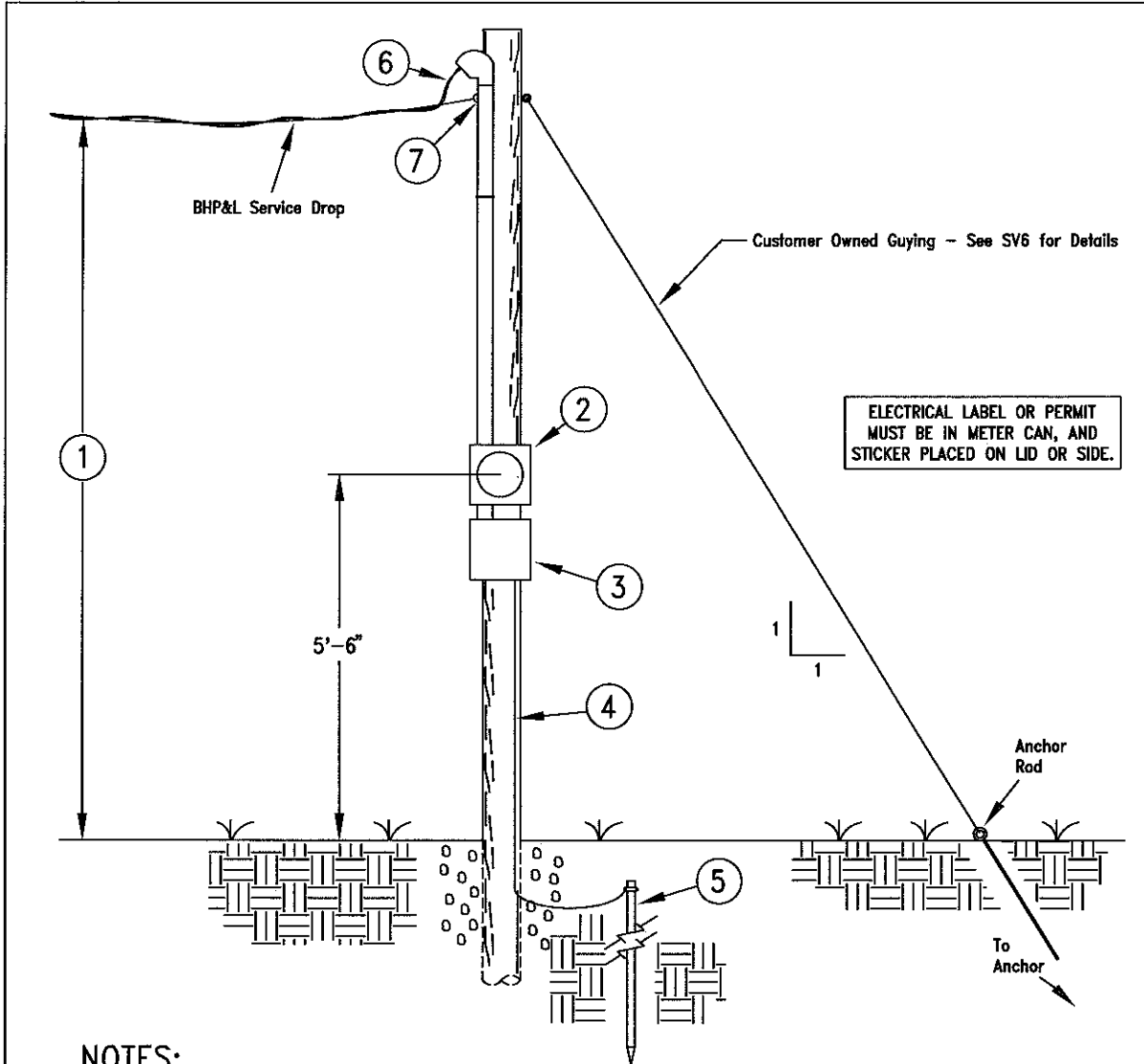

NOTES:

1. a. 14' above finished grade, or from any platform or projection from which conductors may be reached --- 12' if height attachment will not permit. Pole to be 18' minimum length. 4' in ground.
- b. 18' above residential driveways if height of attachment will permit (14' if not). Pole to be 25' minimum length. 4 1/2' in ground.
- c. 18' over streets, more if practical.
- d. 6" x 6" pressure treated post or a class 6 treated pole. 25' pole should be adequate for most situations.
2. Meter can must be BHP&L approved and installed level in all directions, Ringless Type.
3. Customer disconnect equipment -- weather tight -- minimum capacity 30 amperes. Switch box must be covered when inspected.
4. Ground wire -- No. 6 copper minimum.
5. Ground rod -- 8' long -- 5/8" ground rod. A butt wrapped copper ground wire is also acceptable.
6. Minimum conductor No. 8 copper or No. 6 aluminum. Must be 18" in length outside weatherhead.
7. Point of attachment for service must be provided.
8. Temporary service charges must be paid and a permit for temporary service or a wiring affidavit approving the service for connection must be obtained before service can be provided.
9. See SV1 for any other requirements.

DSGN. D.G. / D.D.	TEMPORARY SERVICE	REV DATE 8/95	REV NO. 1
DR. K.M./D.C.L.	OVERHEAD TEMPORARY SERVICE	DRAWING NUMBER	
APPROVED BY DATE		SV6.1	
	BLACK HILLS POWER		

Exhibit

Landfill Leachate Removal and Remediation

Project No LF07-1681

