

GRAPHIC AREA 77.80 SQ FT

NEON CHANNEL LETTERS

SCALE: 3/8" = 1'

NOTES:

- 1) ALL SIGNS TO BE UL APPROVED & LABELED
- 2) INSTALLATION TO MEET ALL NEC & LOCAL CODES
- 3) INSTALL FLUSH TO STOREFRONT

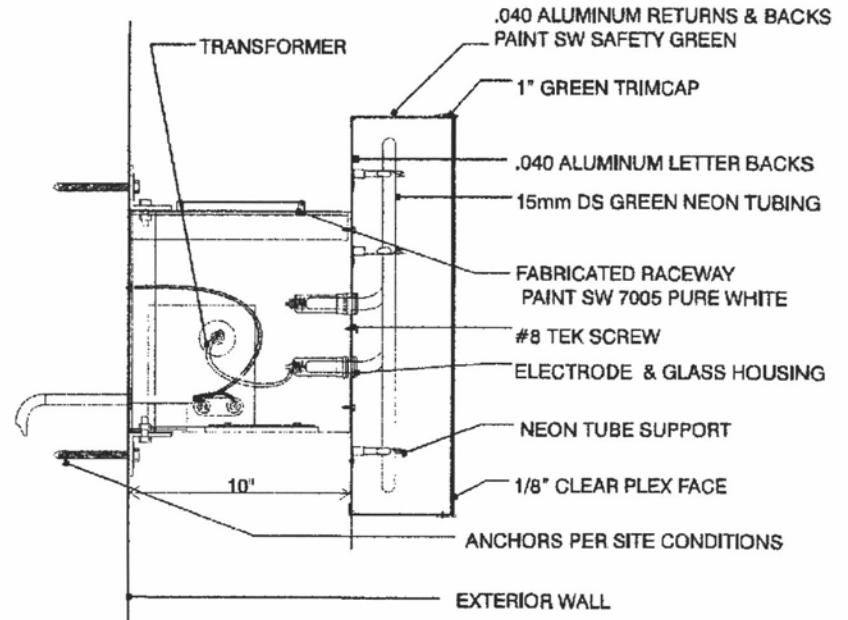

AA LETTER SECTION DETAIL
SCALE: 1 1/2" = 1'

ELECTRICAL: 277V

RECEIVED

JUL 02 2012

RAPID CITY COMMUNITY PLANNING
& DEVELOPMENT SERVICES



834 W. THIRD AVE. COLUMBUS, OHIO 43212 PH. 614.429.2111 FX. 614.429.2150



CLIENT: QUAKER STEAK & LUBE

DATE: 3/30/11

DRAWING #
32274

CONSULTANT:

CLIENT APPROVED

SIGNATURE _____ DATE _____

2.0

DESIGNER:

*THIS IS AN ORIGINAL DESIGN, CREATED FOR YOUR PERSONAL USE IN CONNECTION WITH A PROJECT BEING PLANNED FOR YOU BY ADVANCE SIGN GROUP. THIS PRINT IS NOT TO BE SHOWN TO ANYONE OUTSIDE OF YOUR ORGANIZATION, NOR IS IT TO BE REPRODUCED, COPIED OR EXHIBITED IN ANY FASHION. ADVANCE SIGN GROUP RESERVES THE RIGHT TO CHARGE FOR CREATIVE TIME INVOLVED IN THE PRODUCTION OF THIS DESIGN.

REVISION #

CHECKED:

-

RECEIVED

JUL 02 2012

ALUMINUM ANGLE PLANNING & DEVELOPMENT SERVICES

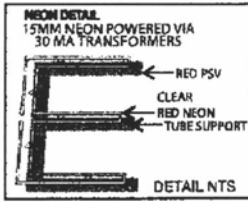

2" x 2" X 1/4" STEEL ANGLE: -BOLT TO ALUMINUM FRAME -WELD TO STEEL PIPE

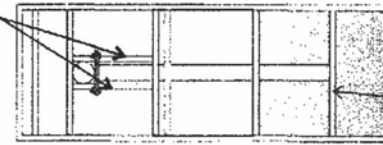

PLAN VIEW

STANDARD 4" SCHEDULE 40 6.625 O.D. X 0.280 WALL

ELECTRICAL: 277V

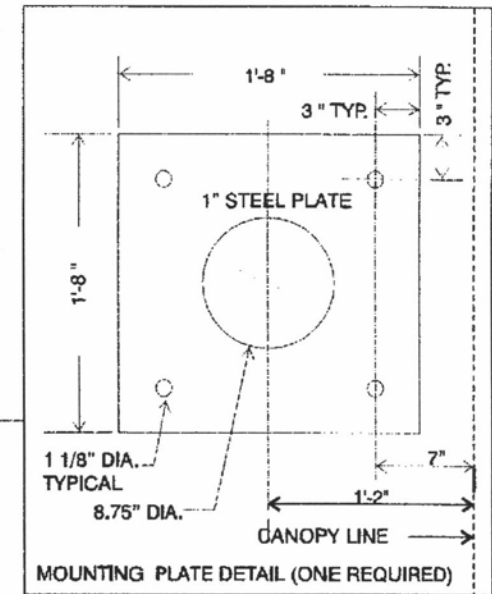

ELECTRICAL: 277V

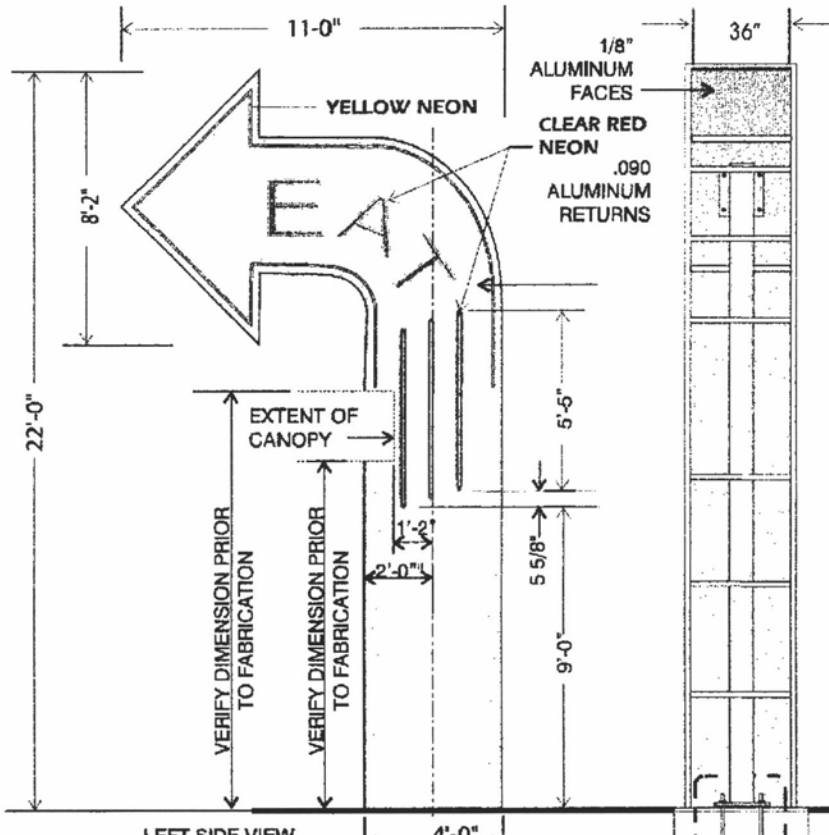

12" X 12" X 1/2" STEEL PLATE MOUNTS WELD TO PIPES & BOLT TOGETHER

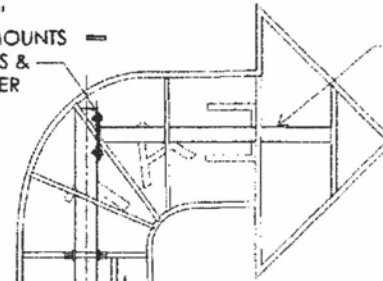

RIGHT SIDE VIEW

DOUBLE FACE NON-ILLUMINATED ARROW SCALE: 3/16" = 1'

- Sherwin Williams 4085 Safety Green
- Sherwin Williams 4084 Safety Yellow
- PSV 3630-53 Cardinal Red

4' X 4' X 6' DP (3.56 CU YD CONCRETE)
1" x 5'-6" J-BOLTS

FRONT VIEW

ADVANCE SIGN GROUP
"YOUR IMAGE IS OUR BUSINESS"

834 W. THIRD AVE. COLUMBUS, OHIO 43212 PH: 614.429.2111 FX: 614.429.2150



CLIENT: QUAKER STEAK & LUBE

DATE: 3/30/11

DRAWING # 32274

CONSULTANT:

CLIENT APPROVED

SIGNATURE: _____ DATE: _____

3.0

DESIGNER:

*THIS IS AN ORIGINAL DESIGN. CREATED FOR YOUR PERSONAL USE IN CONNECTION WITH A PROJECT BEING PLANNED FOR YOU BY ADVANCE SIGN GROUP. THIS PRINT IS NOT TO BE SHOWN TO ANYONE OUTSIDE OF YOUR ORGANIZATION. NOR IS IT TO BE REPRODUCED, COPIED OR EXHIBITED IN ANY FASHION. ADVANCE SIGN GROUP RESERVES THE RIGHT TO CHARGE FOR CREATIVE TIME INVOLVED IN THE PRODUCTION OF THIS DESIGN.

REVISION #

CHECKED:

-

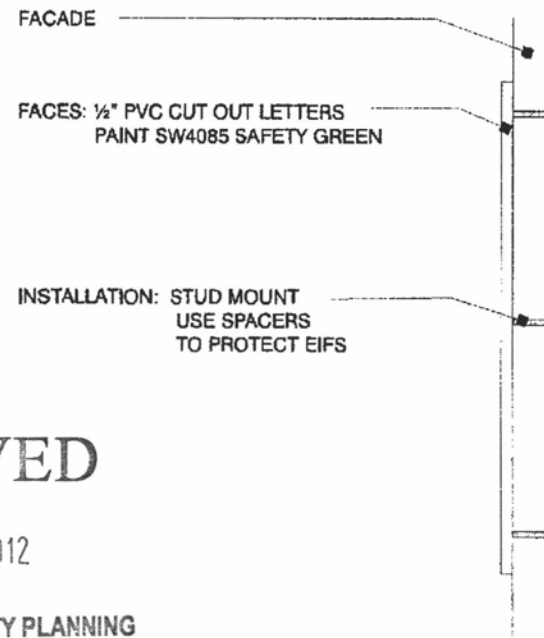

RECEIVED

JUL 02 2012

RAPID CITY COMMUNITY PLANNING
& DEVELOPMENT SERVICES

BB LETTER SECTION DETAIL
SCALE: 3/4" = 1'

ADVANCE SIGN GROUP
"YOUR IMAGE IS OUR BUSINESS"

634 W. THIRD AVE. COLUMBUS, OHIO 43212 PH.614.429.2111 FX.614.429.2150



CLIENT: QUAKER STEAK & LUBE -

DATE: 3/30/11

DRAWING #
32274

CONSULTANT:

CLIENT APPROVED

SIGNATURE _____ DATE _____

4.0

DESIGNER:

*THIS IS AN ORIGINAL DESIGN, CREATED FOR YOUR PERSONAL USE IN CONNECTION WITH A PROJECT BEING PLANNED FOR YOU BY ADVANCE SIGN GROUP. THIS PRINT IS NOT TO BE SHOWN TO ANYONE OUTSIDE OF YOUR ORGANIZATION, NOR IS IT TO BE REPRODUCED, COPIED OR EXHIBITED IN ANY FASHION. ADVANCE SIGN GROUP RESERVES THE RIGHT TO CHARGE FOR CREATIVE TIME INVOLVED IN THE PRODUCTION OF THIS DESIGN.

REVISION #

CHECKED:

-



RECEIVED

JUL 02 2012

RAPID CITY COMMUNITY PLANNING & DEVELOPMENT SERVICES

PANEL SIGN SCALE: 1/2"=1'
 FACES: 1/8" ALUMINUM PANELS PAINTED SHERWIN WILLIAMS 4084 SAFETY YELLOW
 WITH 7725-22 BLACK PSV APPLIED 1ST SURFACE TO PANEL
 MOUNTING: PANELS ARE SCREWED DIRECTLY THRU THE FACE INTO BUILDING
 PANELS MOUNT FLUSH TO WALL
 USE SPACERS TO PROTECT EIFS
 NOTE: VERIFY WINDOW WIDTHS PRIOR TO FABRICATION



834 W. THIRD AVE. COLUMBUS, OHIO 43212 PH. 614.429.2111 FX. 614.429.2150



CLIENT: QUAKER STEAK & LUBE -

DATE: 3/30/11

DRAWING #
32274

CONSULTANT:

CLIENT APPROVED

SIGNATURE

DATE

5.0

DESIGNER:

*THIS IS AN ORIGINAL DESIGN. CREATED FOR YOUR PERSONAL USE IN CONNECTION WITH A PROJECT BEING PLANNED FOR YOU BY ADVANCE SIGN GROUP. THIS PRINT IS NOT TO BE SHOWN TO ANYONE OUTSIDE OF YOUR ORGANIZATION. NOR IS IT TO BE REPRODUCED, COPIED OR EXHIBITED IN ANY FASHION. ADVANCE SIGN GROUP RESERVES THE RIGHT TO CHARGE FOR CREATIVE TIME INVOLVED IN THE PRODUCTION OF THIS DESIGN.

REVISION #

CHECKED:

-

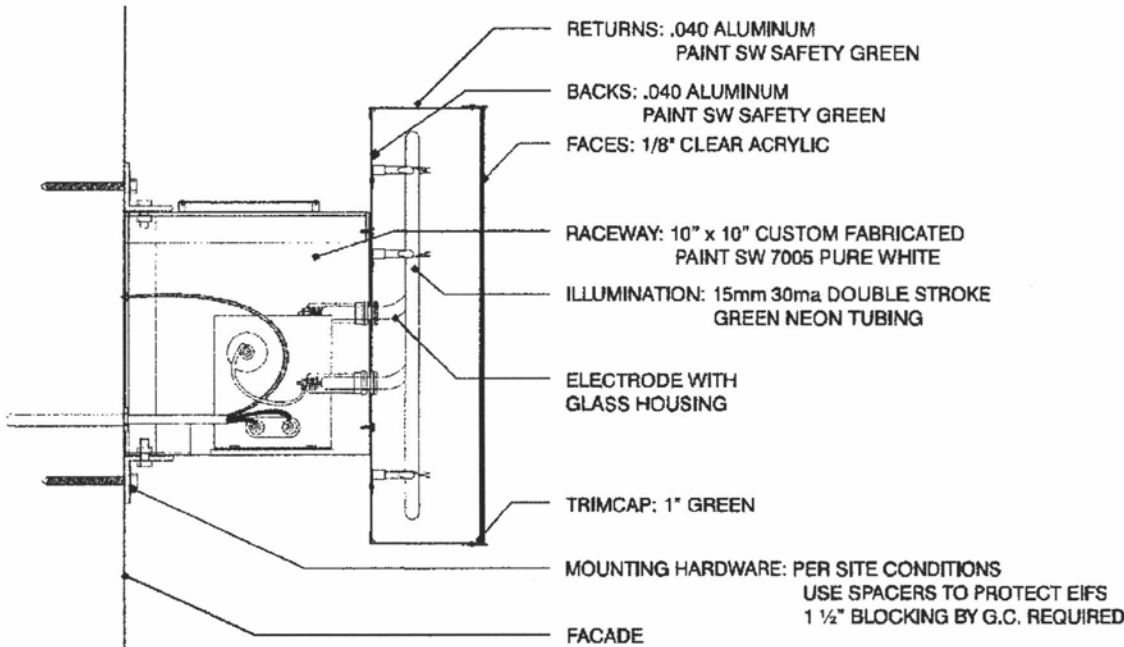
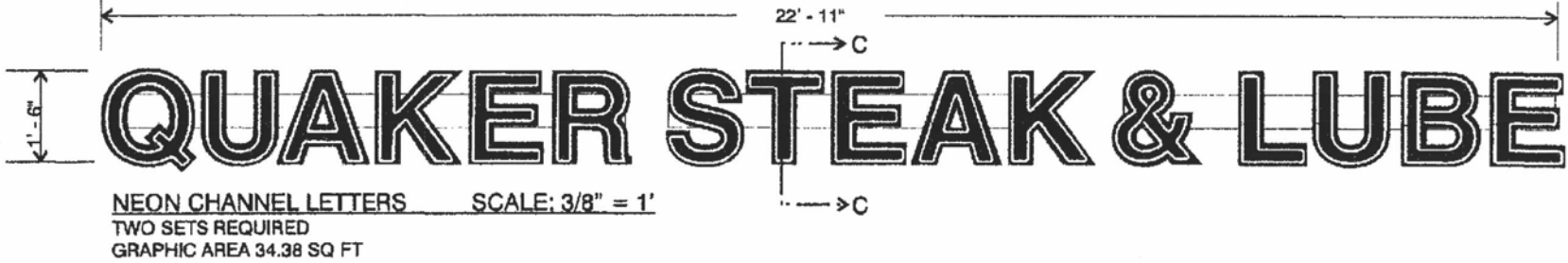

CC LETTER SECTION DETAIL
SCALE: 1 1/2" = 1'

ELECTRICAL: 277V

RECEIVED

JUL 02 2012

RAPID CITY COMMUNITY PLANNING & DEVELOPMENT SERVICES

ADVANCE SIGN GROUP
"YOUR IMAGE IS OUR BUSINESS"

834 W. THIRD AVE. COLUMBUS, OHIO 43212 PH. 614.429.2111 FX. 614.429.2150



CLIENT: QUAKER STEAK & LUBE -

DATE: 3/30/11

DRAWING # 32274

CONSULTANT:

CLIENT APPROVED SIGNATURE _____ DATE _____

6.0

DESIGNER:

*THIS IS AN ORIGINAL DESIGN, CREATED FOR YOUR PERSONAL USE IN CONNECTION WITH A PROJECT BEING PLANNED FOR YOU BY ADVANCE SIGN GROUP. THIS PRINT IS NOT TO BE SHOWN TO ANYONE OUTSIDE OF YOUR ORGANIZATION, NOR IS IT TO BE REPRODUCED, COPIED OR EXHIBITED IN ANY FASHION. ADVANCE SIGN GROUP RESERVES THE RIGHT TO CHARGE FOR CREATIVE TIME INVOLVED IN THE PRODUCTION OF THIS DESIGN.

REVISION #

CHECKED:

-

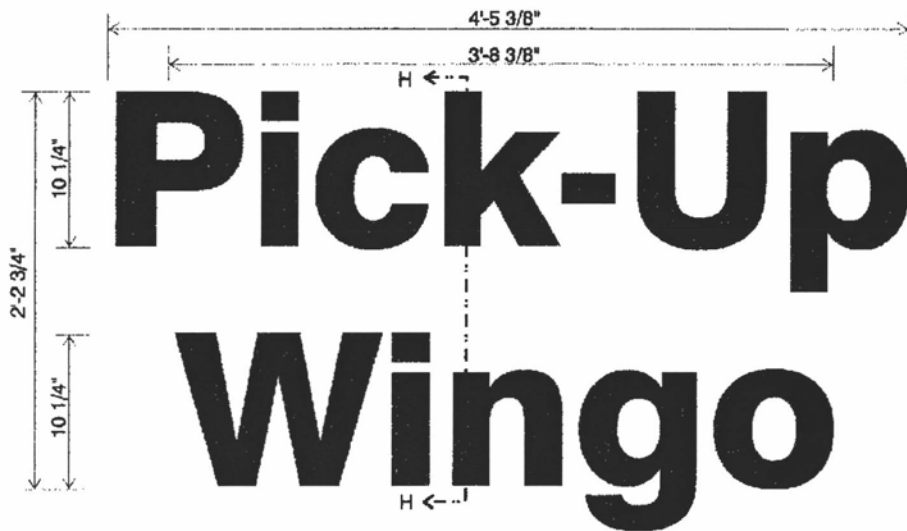

PVC LETTERS SCALE: 1" = 1'
 GRAPHIC AREA 6.96 SQ FT

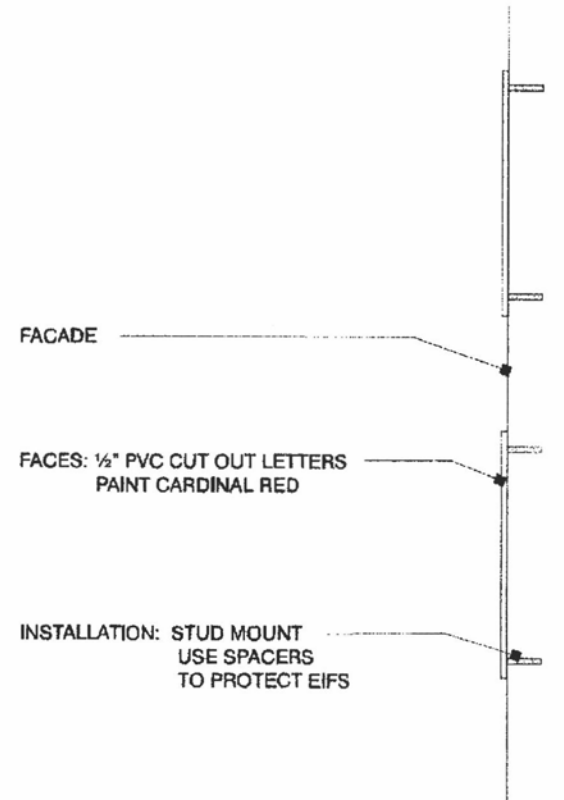

HH LETTER SECTION DETAIL
 SCALE: 3/4" = 1'



834 W. THIRD AVE. COLUMBUS, OHIO 43212 PH. 614.429.2111 FX. 614.429.2150



CLIENT: QUAKER STEAK & LUBE

DATE: 3/30/11

DRAWING #
 32274

CONSULTANT: N. WASSERSTROM

CLIENT APPROVED SIGNATURE _____ DATE _____

7.0

DESIGNER: CRAIG REYNOLDS

*THIS IS AN ORIGINAL DESIGN. CREATED FOR YOUR PERSONAL USE IN CONNECTION WITH A PROJECT BEING PLANNED FOR YOU BY ADVANCE SIGN GROUP. THIS PRINT IS NOT TO BE SHOWN TO ANYONE OUTSIDE OF YOUR ORGANIZATION. NOR IS IT TO BE REPRODUCED, COPIED OR EXHIBITED IN ANY FASHION. ADVANCE SIGN GROUP RESERVES THE RIGHT TO CHARGE FOR CREATIVE TIME INVOLVED IN THE PRODUCTION OF THIS DESIGN.

REVISION #

CHECKED:

-

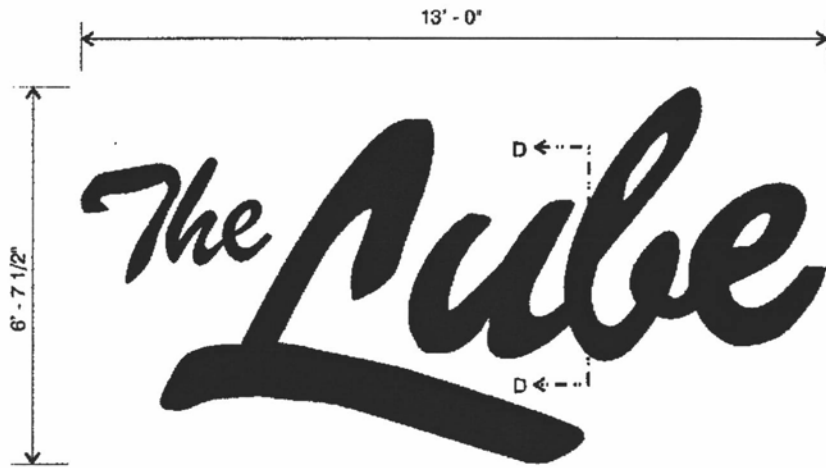

LED HALO LIT CHANNEL LETTERS SCALE: 3/8" = 1'
 GRAPHIC AREA 85.85 SQ FT

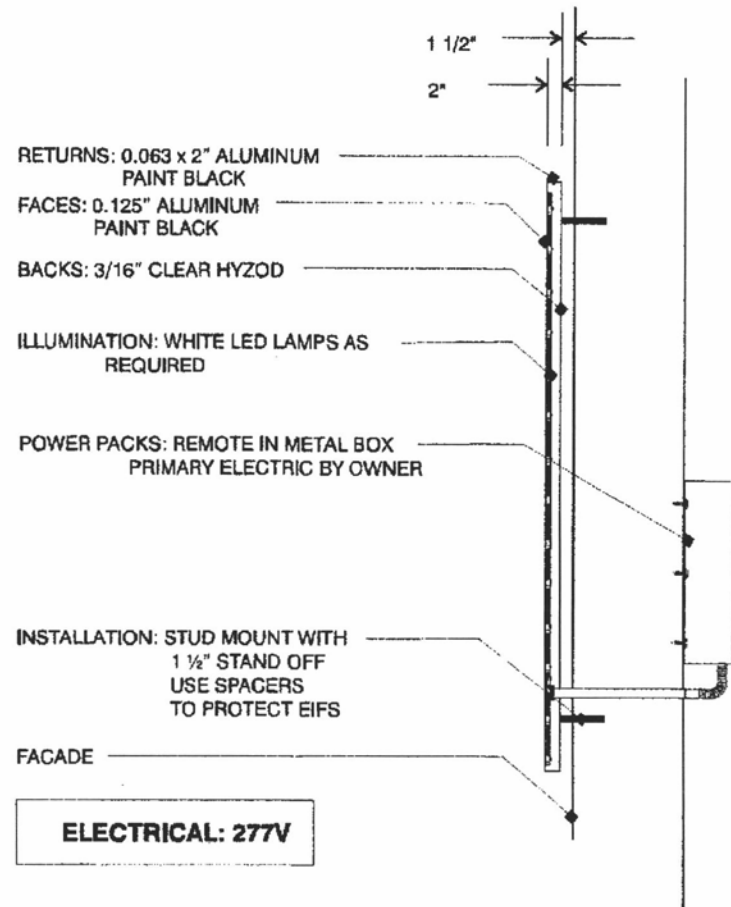

ELECTRICAL: 277V

DD LETTER SECTION DETAIL
 SCALE: 1/2" = 1'



834 W. THIRD AVE. COLUMBUS, OHIO 43212 PH.614.429.2111 FX.614.429.2150



CLIENT: QUAKER STEAK & LUBE -

DATE: 3/30/11

DRAWING #
 32274

CONSULTANT:

CLIENT APPROVED SIGNATURE _____ DATE _____

8.0

DESIGNER:

*THIS IS AN ORIGINAL DESIGN. CREATED FOR YOUR PERSONAL USE IN CONNECTION WITH A PROJECT BEING PLANNED FOR YOU BY ADVANCE SIGN GROUP. THIS PRINT IS NOT TO BE SHOWN TO ANYONE OUTSIDE OF YOUR ORGANIZATION. NOR IS IT TO BE REPRODUCED, COPIED OR EXHIBITED IN ANY FASHION. ADVANCE SIGN GROUP RESERVES THE RIGHT TO CHARGE FOR CREATIVE TIME INVOLVED IN THE PRODUCTION OF THIS DESIGN.

REVISION #

CHECKED:

-

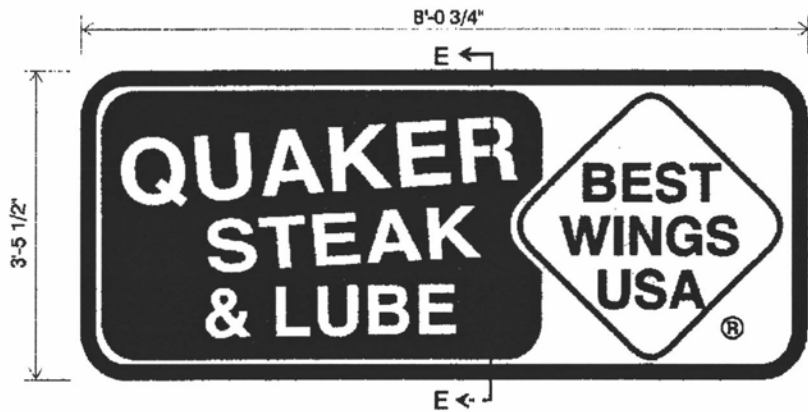

S/F WALL SIGN SCALE: 1/2" = 1'
 GRAPHIC AREA 27.88 SQ FT

CABINET: CUSTOM FABRICATED
 2SQ ALUMINUM ANGLE FRAME
 .063 RETURNS
 .063 BACK
 .063 RETAINERS
 PAINT SW BLACK SEMI-GLOSS

FACES: 3/16 WHITE POLYCARBONATE WITH
 3630-126 GREEN
 3630-015 YELLOW AND
 7725-22 BLACK PSV
 APPLIED 1ST SURFACE

ILLUMINATION: WHITE LED
 PRIMARY CIRCUIT BY OWNER

INSTALLATION: EIGHT (8) ANCHORS MINIMUM
 MOUNT THROUGH ANGLE FRAME
 USE SPACERS FOR EIFS TO PROTECT WALL
 3/8" LAG, LAG & SHIELD OR REDHEAD
 PER FIELD CONDITIONS

ELECTRICAL: 277V

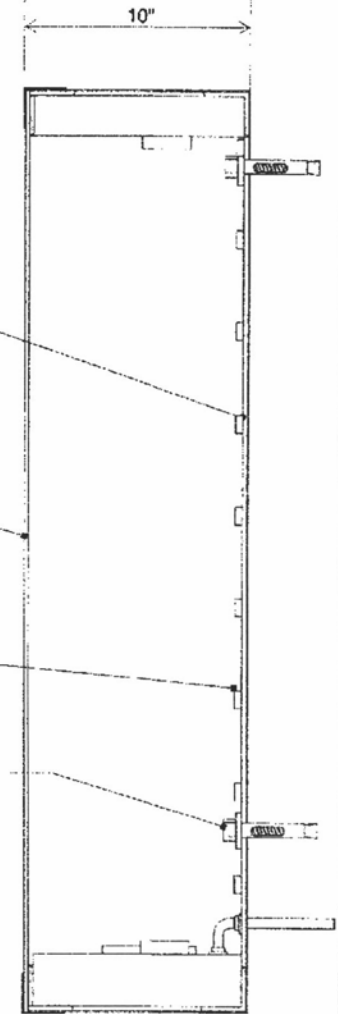

AA CABINET SECTION DETAIL
 SCALE: 1 1/2" = 1'



834 W. THIRD AVE. COLUMBUS, OHIO 43212 PH: 614.429.2111 FX: 614.429.2150



CLIENT: QUAKER STEAK & LUBE - SPRINGFIELD, IL

DATE: 3/30/11

DRAWING #
32274

CONSULTANT: N. WASSERSTROM

CLIENT APPROVED

SIGNATURE _____ DATE _____

9.0

DESIGNER: CRAIG REYNOLDS

*THIS IS AN ORIGINAL DESIGN, CREATED FOR YOUR PERSONAL USE IN CONNECTION WITH A PROJECT BEING PLANNED FOR YOU BY ADVANCE SIGN GROUP. THIS PRINT IS NOT TO BE SHOWN TO ANYONE OUTSIDE OF YOUR ORGANIZATION, NOR IS IT TO BE REPRODUCED, COPIED OR EXHIBITED IN ANY FASHION. ADVANCE SIGN GROUP RESERVES THE RIGHT TO CHARGE FOR CREATIVE TIME INVOLVED IN THE PRODUCTION OF THIS DESIGN.

REVISION #

CHECKED:

-

→ |← 3 3/4" +/-

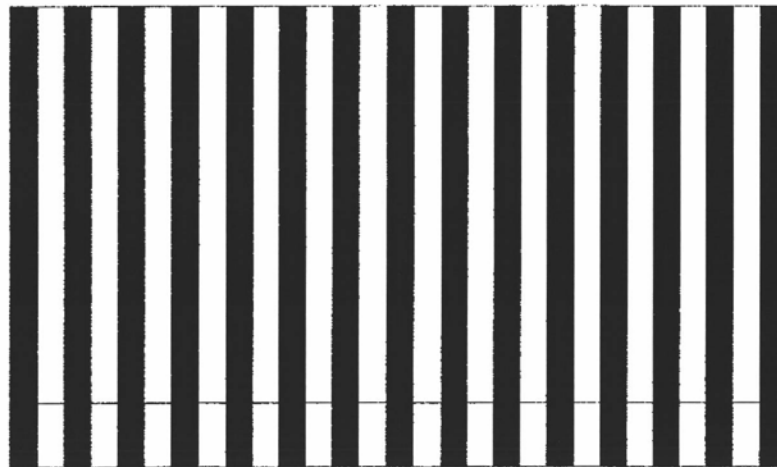

VERIFY

ONE (1) AWNING TO BE 13' IN LENGTH
 ONE (1) AWNING TO BE 22'-6" IN LENGTH

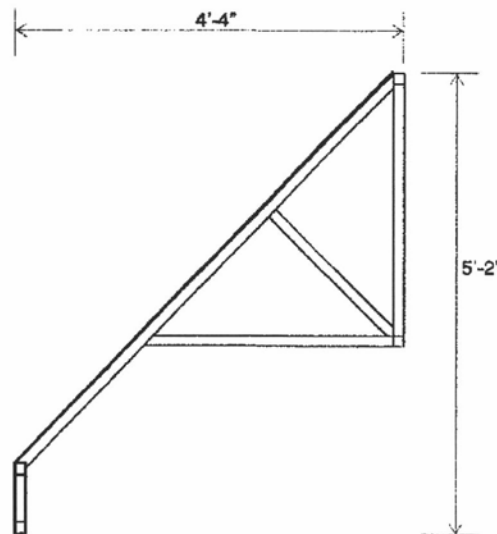

QS&L AWNINGS SCALE: 1/2" = 1'
 FABRIC: SUNBRELLA FIRESIST
 PATTERN: 82015 IVORY
 82003 FOREST GREEN
 HEAT SEAMED STRIPES
 STRIPE: APPROXIMATELY 3 3/4" WIDE
 FRAME: OPEN ENDS
 WHITE POWDER COATED



834 W. THIRD AVE. COLUMBUS, OHIO 43212 PH.614.429.2111 FX.614.429.2150



CLIENT: QUAKER STEAK & LUBE -

DATE: 3/30/11

DRAWING #
32274

CONSULTANT:

CLIENT APPROVED

SIGNATURE _____ DATE _____

11.0

DESIGNER:

*THIS IS AN ORIGINAL DESIGN. CREATED FOR YOUR PERSONAL USE IN CONNECTION WITH A PROJECT BEING PLANNED FOR YOU BY ADVANCE SIGN GROUP. THIS PRINT IS NOT TO BE SHOWN TO ANYONE OUTSIDE OF YOUR ORGANIZATION. NOR IS IT TO BE REPRODUCED, COPIED OR EXHIBITED IN ANY FASHION. ADVANCE SIGN GROUP RESERVES THE RIGHT TO CHARGE FOR CREATIVE TIME INVOLVED IN THE PRODUCTION OF THIS DESIGN.

REVISION #

CHECKED:

-

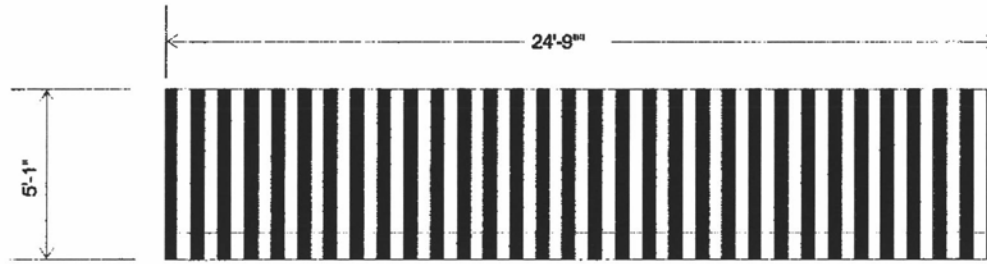

MINIMUM 1 1/2" BLOCKING
OR THRU-BOLT REQUIRED
FOR PATIO AWNING
INSTALLATION
BLOCKING BY G.C.

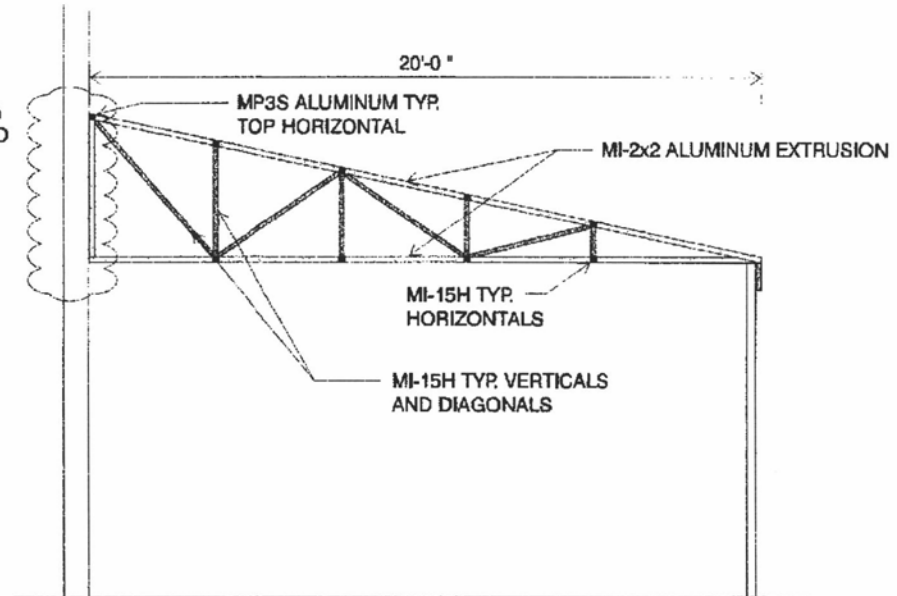

NOTE: TRUSSES MAX 3' O.C.

QS&L AWNINGS SCALE: 3/16" = 1'
 FABRIC: SUNBRELLA FIRESIST
 PATTERN: 82015 IVORY
 82003 FOREST GREEN
 HEAT SEAMED STRIPES
 STRIPE: APPROXIMATELY 3 3/4" WIDE
 FRAME: OPEN ENDS
 WHITE POWDER COATED



834 W. THIRD AVE. COLUMBUS, OHIO 43212 PH.614.429.2111 FX.614.429.2150



CLIENT: QUAKER STEAK & LUBE

DATE: 3/30/11

DRAWING #
32274

CONSULTANT

CLIENT APPROVED

SIGNATURE _____ DATE _____

12.0

DESIGNER:

*THIS IS AN ORIGINAL DESIGN CREATED FOR YOUR PERSONAL USE IN CONNECTION WITH A PROJECT BEING PLANNED FOR YOU BY ADVANCE SIGN GROUP. THIS PRINT IS NOT TO BE SHOWN TO ANYONE OUTSIDE OF YOUR ORGANIZATION. NOR IS IT TO BE REPRODUCED, COPIED OR EXHIBITED IN ANY FASHION. ADVANCE SIGN GROUP RESERVES THE RIGHT TO CHARGE FOR CREATIVE TIME INVOLVED IN THE PRODUCTION OF THIS DESIGN.

REVISION #

CHECKED:

-