































MATERIALS & SYMBOLS

-  GRAVEL
-  UNDISTURBED SOIL
-  DISTURBED SOIL
-  CONCRETE
-  CEMENT BLOCK
-  BRICK
-  ASPHALT
-  STEEL
-  ACOUSTICAL TILE
-  RIGID INSULATION
-  BATT INSULATION
-  BLOWN INSULATION
-  SMALL SCALE GYPSUM
-  LARGE SCALE GYPSUM
-  PLYWOOD
-  PARTICLE BOARD
-  PLASTER
-  ROUGH WOOD
-  WOOD BLOCKING
-  DIMENSION
-  TEXT LEADER
-  ANY ROOM
-  SPACE SYMBOL
-  DOOR SYMBOL
-  WINDOW SYMBOL
-  ELEVATION MARKER
-  CENTER LINE
-  PROPERTY LINE
-  DETAIL NUMBER
-  DETAIL REFERENCE
-  SHEET NUMBER

SHEET INDEX

- COVER SHEET
- ARCHITECTURAL
- A1 BASEMENT FLOOR PLAN / WALL TYPES
 - A2 FIRST FLR DEMO, REMODEL PLANS AND ENLARGED PLANS
 - A3 SECOND FLR DEMO, REMODEL PLANS AND ENLARGED PLANS
 - A4 THIRD FLR DEMO, REMODEL PLANS AND ENLARGED PLANS
 - A5 STAIR SECTIONS AND DETAILS
 - A6 WALL SECTIONS AND DETAILS
 - A7 GENERAL SPECIFICATIONS, NOTES & MATERIALS

CODE ANALYSIS & REVIEW

CODES USED: 2006 IBC, 2006 IEBC, 2010 ADA STANDARDS, ICC ANSI IT1

BUILDING SPRINKLERED PER NFPA 13-R SYSTEM THROUGHOUT
BUILDING HEIGHT: 3 STORIES; SPRINKLER SUBSTITUTE TO ADD ONE STORY PER TABLE 503.

OCCUPANCY GROUP: R-2 APARTMENT BUILDING/ B OFFICE (23 UNITS)
TYPE OF CONSTRUCTION: TYPE V-B; WOOD FRAMED

SQUARE FOOTAGE: 3,140 G.S.F. PER FLOOR

EXITING REQUIREMENTS: PER CHAPTER 10/ FIRE ESCAPE PER SEC 3403 & 3404

OCCUPANCY SEPARATIONS: B/R-2 = 1 HR PER TABLE 508.3.3

CORRIDOR WALLS: 1/2 HOUR PER TABLE 1011

HORIZONTAL FLOOR ASSEMBLY: 1 HOUR PER SECTION 711

TRAVEL DISTANCE: LESS THAN 250 FEET PER TABLE 1016.1

COMMON PATH OF EGRESS: LESS THAN 75 FEET PER 104.3

COMMON UNIT CONSTRUCTION: COMMON WALLS = 1 HOUR PER SEC 708.3
COMMON FLR/CLG = 1/2 HOUR PER SEC 711.3

EXIT STAIRWAYS: PER SECTION 3403 & IEBC
FIRE ESCAPE: PER SECTION 3404 & IEBC
FIRE EXTINGUISHERS: PER NFPA 10

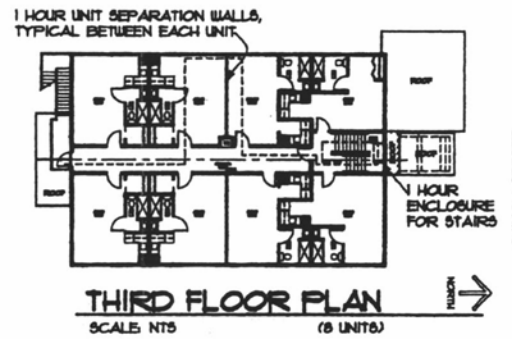
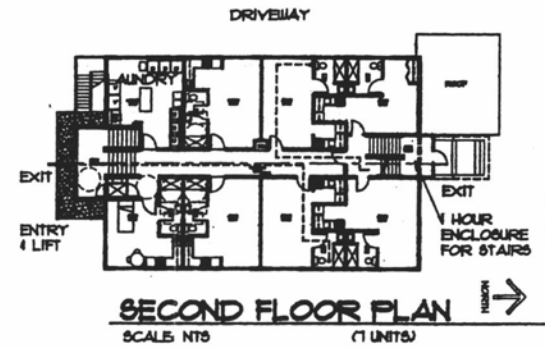
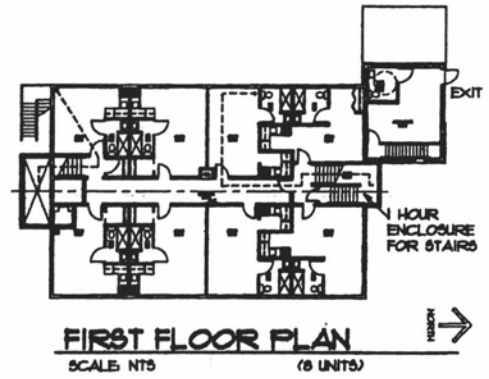

RECEIVED

FEB 24 2012

RAPID CITY COMMUNITY PLANNING & DEVELOPMENT SERVICES

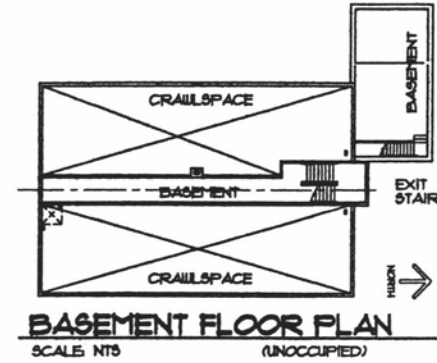

STAMPS

SET #

COPYRIGHT 2008. ALL RIGHTS RESERVED. NO PART OF THIS DOCUMENT MAY BE REPRODUCED IN ANY FORM OR BY ANY MEANS WITHOUT PERMISSION FROM LUND ASSOCIATES LTD.

OWEN'S APARTMENT BUILDING REMODEL

**603 QUINCY STREET
RAPID CITY, SOUTH DAKOTA 57701**

JOB: OWEN'S APARTMENT BUILDING REMODEL
 CONSULT. NO. 11-011 DATE: 2-03-12

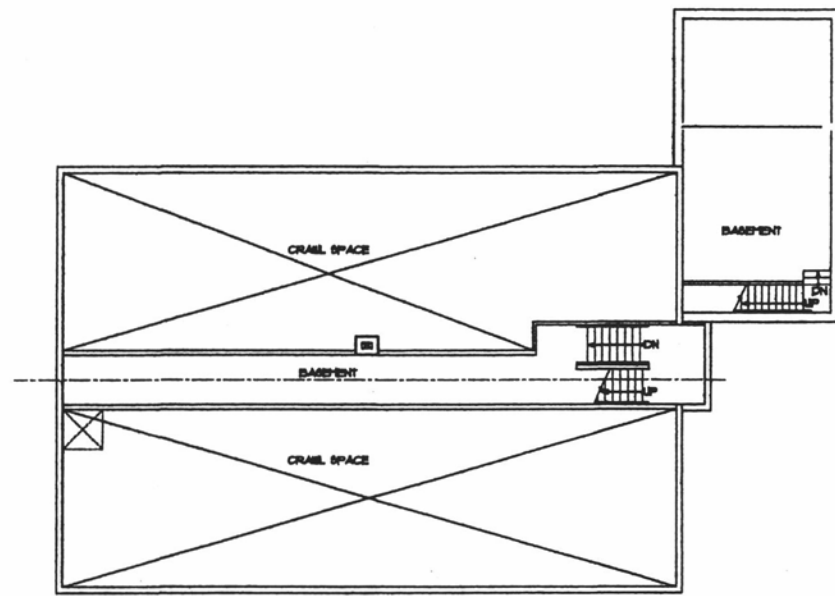

1 BASEMENT FLOOR PLAN
AI SCALE 1/4" = 1'-0"

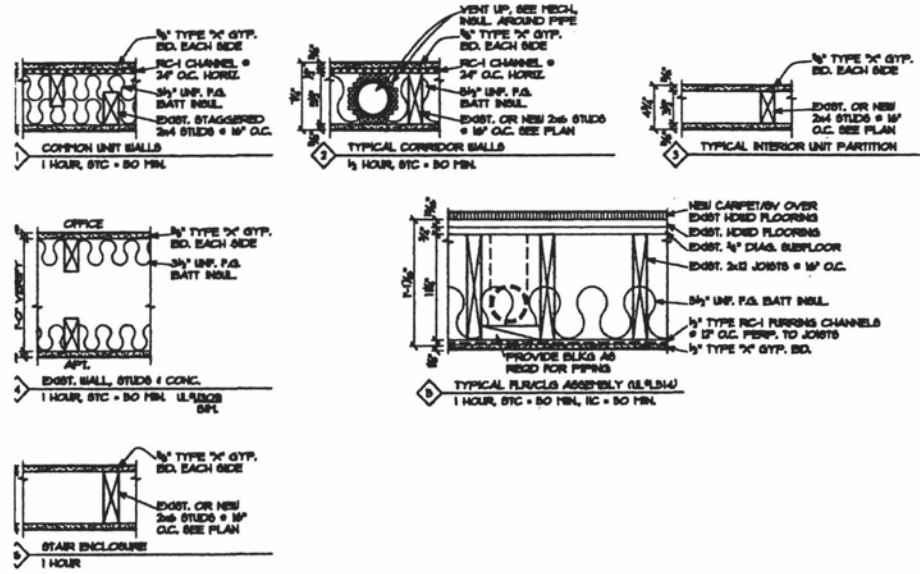

WALL TYPES
SCALE 1/4" = 1'-0"

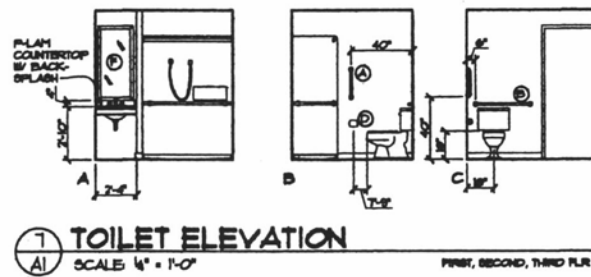
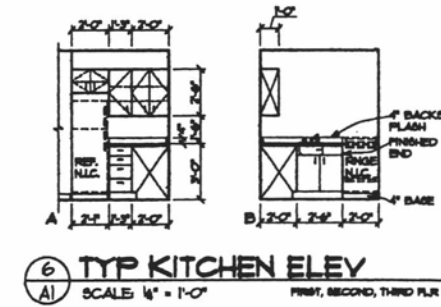
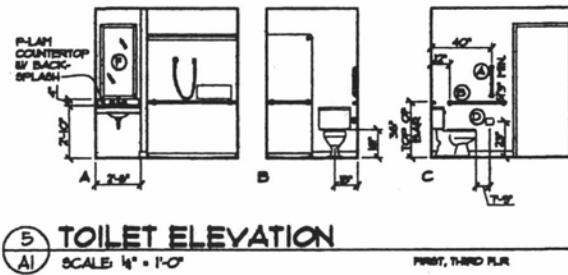
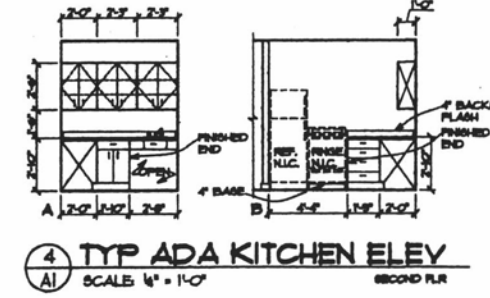
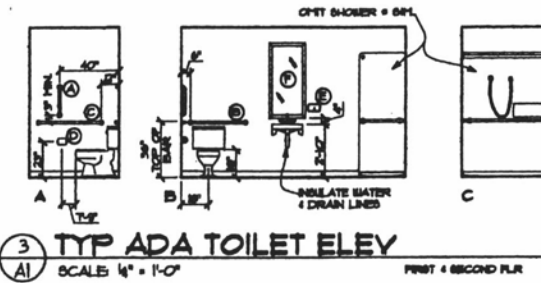

- 1) 1/2" 30 VERT. GRAB BAR
- 2) 3/4" 30 HORIZ. GRAB BAR
- 3) 4" 1 1/2" 30 HORIZ. GRAB BAR
- 4) TOILET PAPER HOLDER
- 5) SOAP DISPENSER
- 6) 24" WASH SINK

QUEENS APARTMENT BUILDING REMODEL
 603 QUINCY STREET
 RAPID CITY, SD 57101
 2-03-12
 11-01
 ARCHITECTURE • INTERIOR DESIGN • PLANNING
 1821 SHERMAN LAKE ROAD
 RAPID CITY, SOUTH DAKOTA 57702-3423
 605-348-3255
 LUND ASSOCIATES LTD.



AI

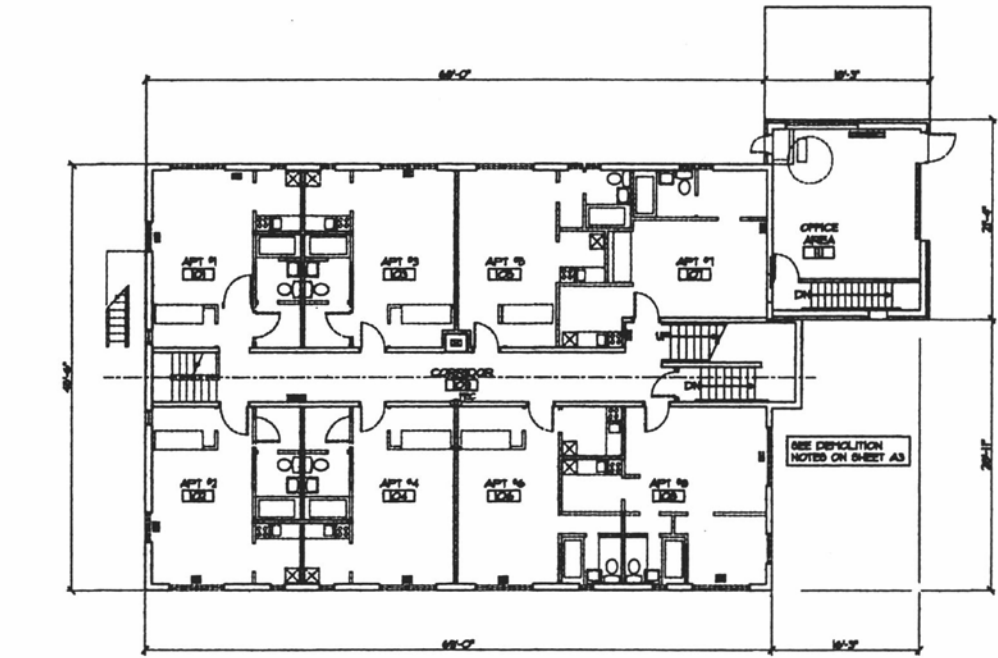

1 FIRST FLOOR DEMOLITION PLAN
SCALE 1/4" = 1'-0"

WALL RATING LEGEND

1 HR. FIRE BARRIER	-----
--------------------	-------

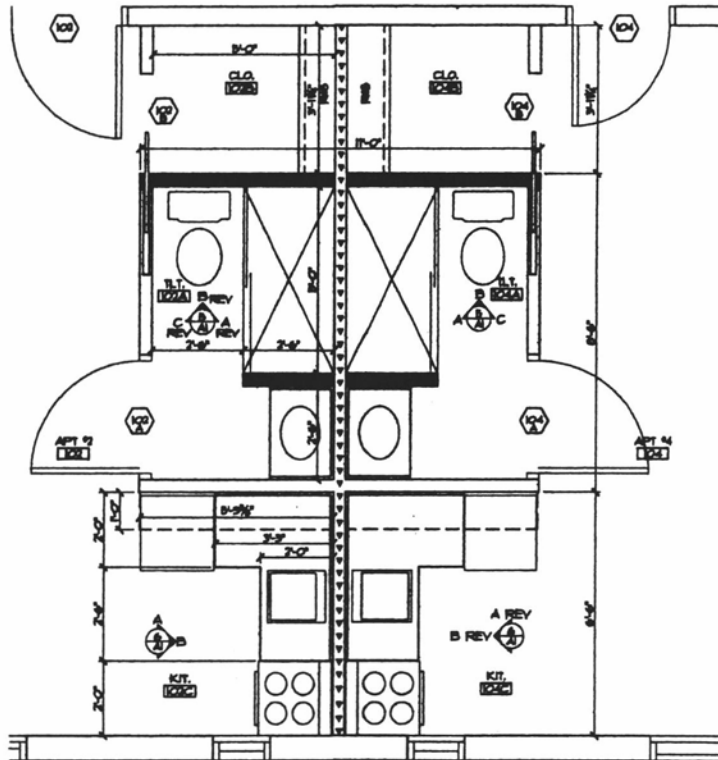

3 ENLARGED TLT/ KITCHEN PLAN
SCALE 1/4" = 1'-0"

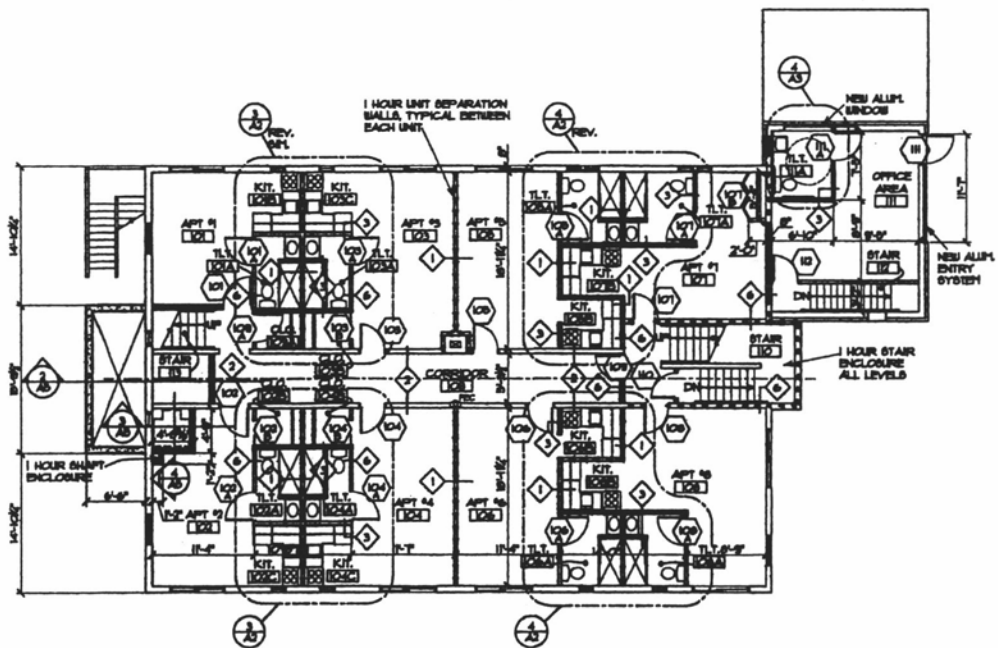

2 FIRST FLOOR REMODEL PLAN
SCALE 1/4" = 1'-0"

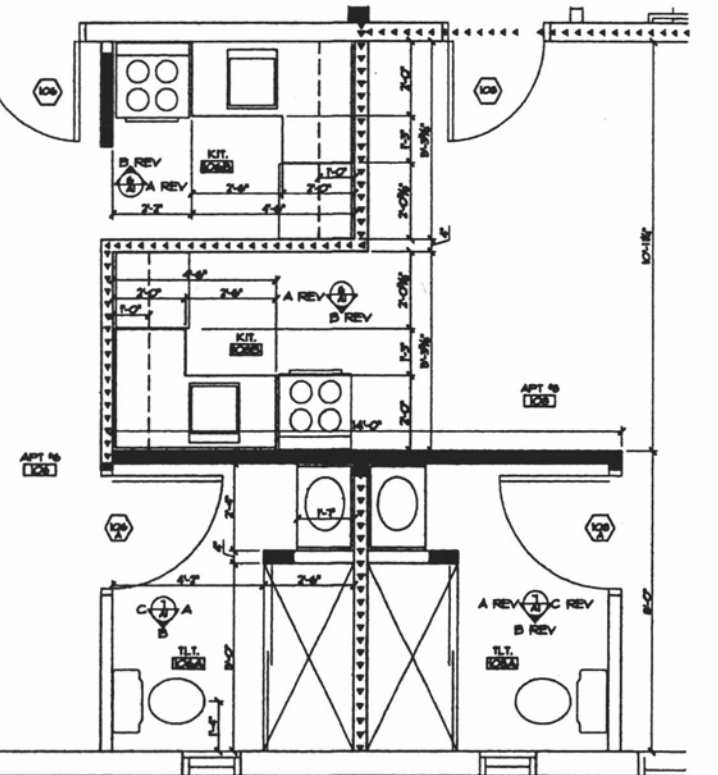

4 ENLARGED TLT/ KITCHEN PLAN
SCALE 1/4" = 1'-0"



QUENS APARTMENT BUILDING REMODEL	
603 QUINCY STREET RAPID CITY, SD 57101	
DATE: 2-03-12	NO. 20
PROJECT: FIRST FLR DEMO, REMODEL PLANS AND ENLARGED PLANS	
ARCHITECT: LUND ASSOCIATES LTD.	PLANNING
1821 SHERMAN LAKE ROAD RAPID CITY, SOUTH DAKOTA 57702-3423 605-347-0605	
ARCHITECTURE • INTERIOR DESIGN • PLANNING	
A2	

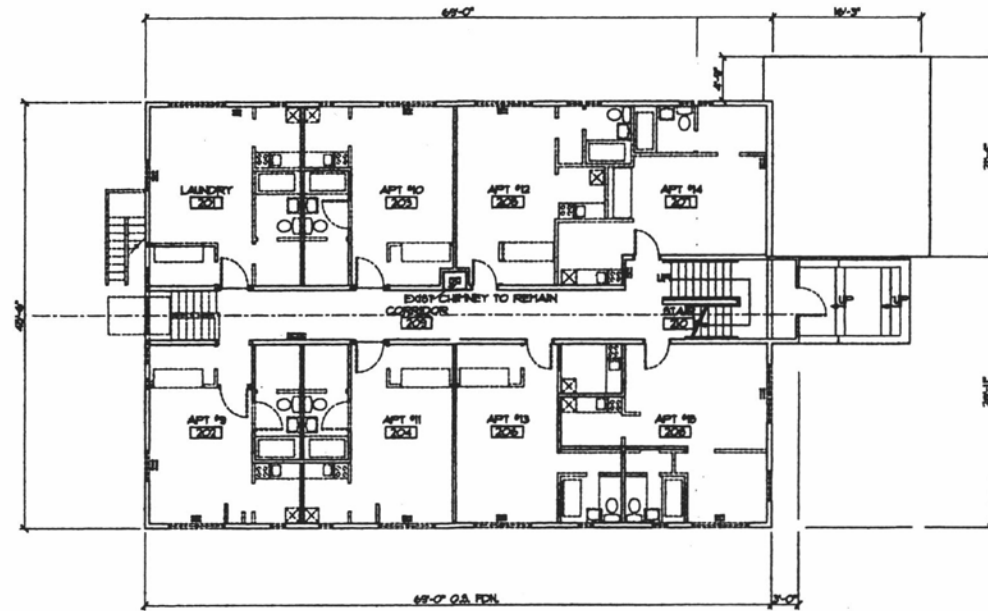

1 SECOND FLOOR DEMOLITION PLAN
A3 SCALE 1/4" = 1'-0"

WALL RATING LEGEND

1 HR. FIRE BARRIER	*****
--------------------	-------

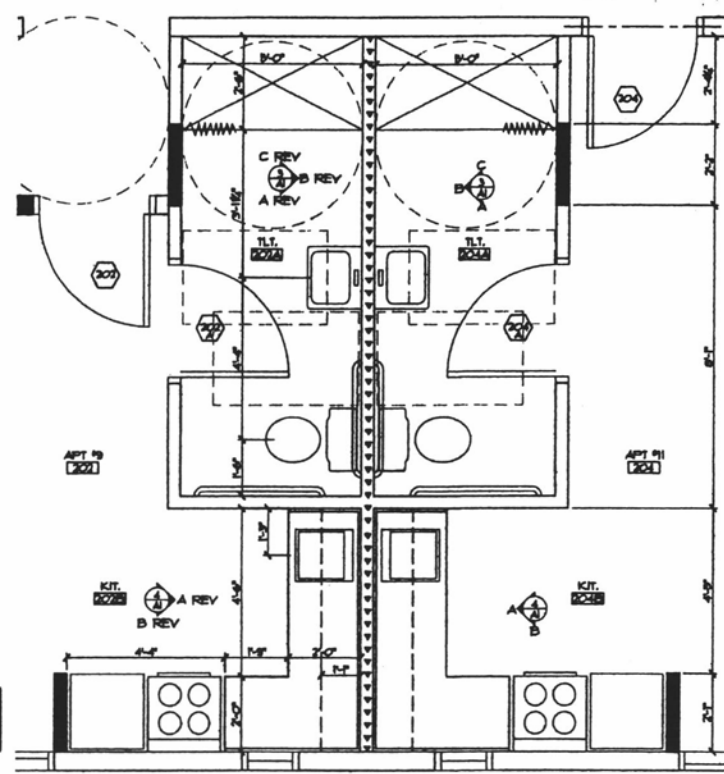

3 TYPICAL ADA TLT/KITCHEN PLAN
A3 SCALE 1/4" = 1'-0"

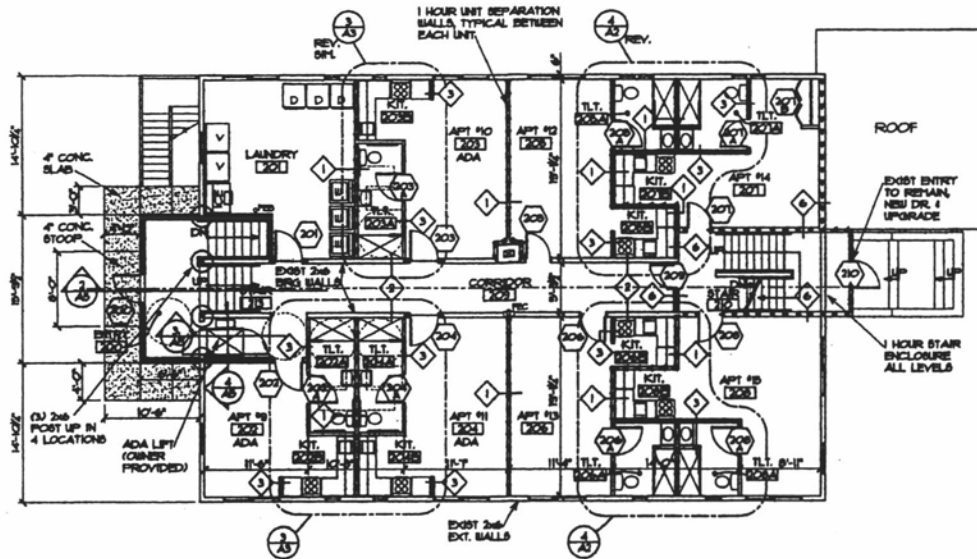

2 SECOND FLOOR REMODEL PLAN
A3 SCALE 1/4" = 1'-0"

- DEMOLITION NOTES**
1. REMOVE EXIST. WALLS SHOWN DOTTED
 2. REMOVE ALL EXIST. KITCHEN APPLIANCES AND CABINETS
 3. REMOVE ALL EXIST. BATHROOM FIXTURES AND ACCESSORIES
 4. REMOVE ALL EXIST. MURPHY BED ASSEMBLIES
 5. REMOVE ALL EXIST. DOORS, FRAMES & HARDWARE
 6. REMOVE ALL EXIST. PLUMBING & ELECTRICAL SYSTEMS THROUGHOUT
 7. REMOVE ALL EXIST. FLR, WALL & CLG. FINISHES THROUGHOUT
 8. REMOVE ALL EXIST. WINDOWS SHOWN DASHED
 9. REMOVE ALL EXIST. RADIATORS & HEATING SYSTEM
 10. REMOVE EXIST. STAIR & FLOOR SYSTEM AS REQD FOR NEW LIFT & STAIRS
 11. REMOVE EXIST. EXTERIOR WOOD FIRE ESCAPE
 12. REMOVE & EXCAVATE FOR NEW ADDITION AS REQD.
 13. REMOVE ALL EXIST. EXTERIOR SIDING NEW WINDOWS & SIDING BY OTHER

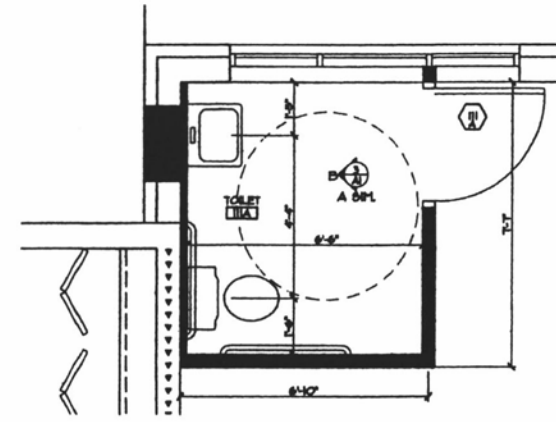

4 ENLARGED TLT. PLAN
A3 SCALE 1/4" = 1'-0"



QUENS APARTMENT BUILDING REMODEL
 603 QUINCY STREET RAPID CITY, SD 57101
 DATE: 2-07-12
 SHEET NO: CD
 PROJECT NO: 11011
 1821 SHERMAN LAKE ROAD
 RAPID CITY, SOUTH DAKOTA 57702-3423
 605-348-3365
 ARCHITECTURE • INTERIOR DESIGN • PLANNING
LUND & ASSOCIATES LTD.
 A3

DOOR SCHEDULE

Table with columns: DOOR NO., SIZE, DOOR MATL., DOOR ELEV., FRM. MATL., FRM. ELEV., FRM. LBL., GLASS, DTL., HDBL. RECD., REMARKS. Lists specifications for doors from 101 to 309.

Legend and hardware groups. Legend includes MD (WOOD), SC (SOLID CORE), IG (INSULATED GLASS), HW (HARDWARE SET), etc. Hardware groups 1-7 list items like exterior doors, lever locks, and panic exits.

ROOM FINISH SCHEDULE

Table with columns: ROOM NO., ROOM NAME, FLOOR MATERIAL, BASE, WORTH, P, EAST, P, SOUTH, P, WEST, P, CEILING, P, REMARKS. Lists finishes for rooms from 101 to 309.

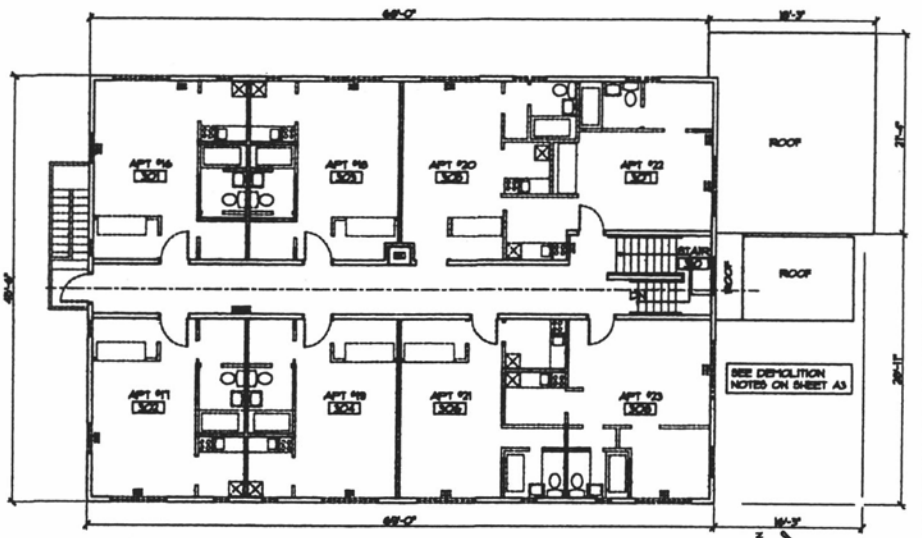

1 THIRD FLOOR DEMOLITION PLAN SCALE 1/8" = 1'-0"

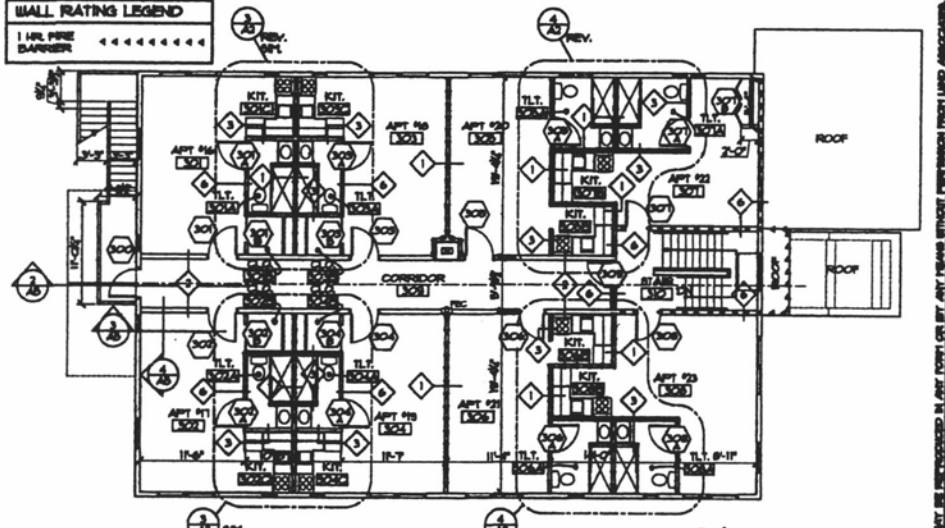

2 THIRD FLOOR REMODEL PLAN SCALE 1/8" = 1'-0"

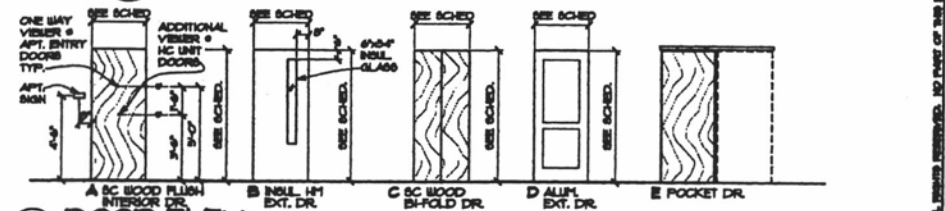

3 DOOR ELEV SCALE 1/4" = 1'-0"

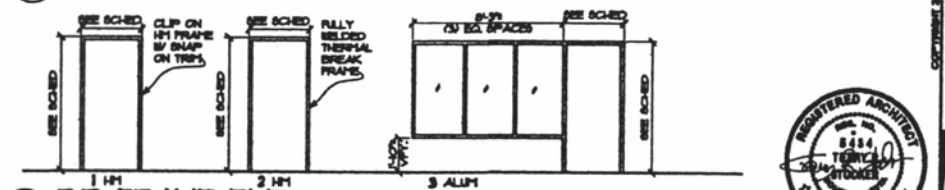

4 DR. FRAME ELEV SCALE 1/4" = 1'-0"

Project title block and title block containing: QUENS APARTMENT BUILDING REMODEL, 603 QUINCY STREET, RAPID CITY, SD 57101, LUND & ASSOCIATES ARCHITECTURE + INTERIOR DESIGN + PLANNING, 1821 SHERIDAN LAKE ROAD, RAPID CITY, SOUTH DAKOTA 57702-3423, 605-348-3055. Includes a professional seal for a registered architect.