

1 TYPE "A" ATTACHED GARAGE PLAN
 1/4" = 1'-0"
 315 DOCKTILE ST
 303 DOCKTILE TLE ST
 1903 WOODO AVE
 316 FACARTHUR ST
 403 DOCKTILE ST BLD ALT 1

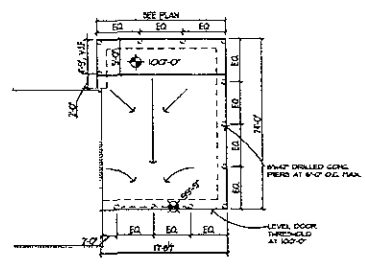

2 FOUNDATION PLAN
 1/4" = 1'-0"
 TYPE "A" GARAGE
2 SLAB DRAINAGE NOTES:
 1. PERFORMER OF SLAB IS LEVEL AT EXIST 100" OF EXIST OVERHEAD DOOR SLAB IS AT 100"
 2. MASS SLAB IS TO BE SLOPED TO THE INSIDE AND OUT UNDER THE OVERHEAD DOOR

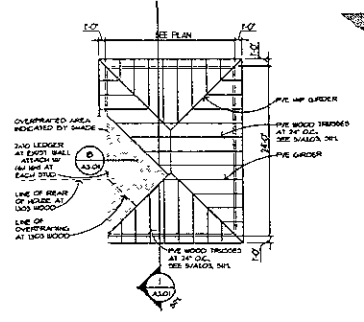

3 ROOF FRAMING PLAN
 1/4" = 1'-0"
 TYPE "A" GARAGE - HIP ROOF
 SET AT 404 FACARTHUR ST

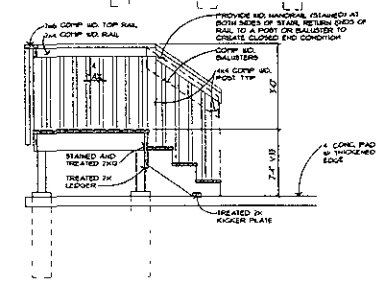
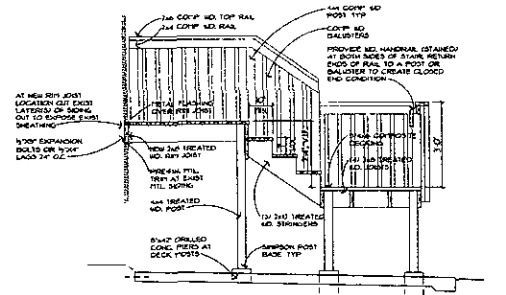

4 STAIR SECTIONS
 1/4" = 1'-0"

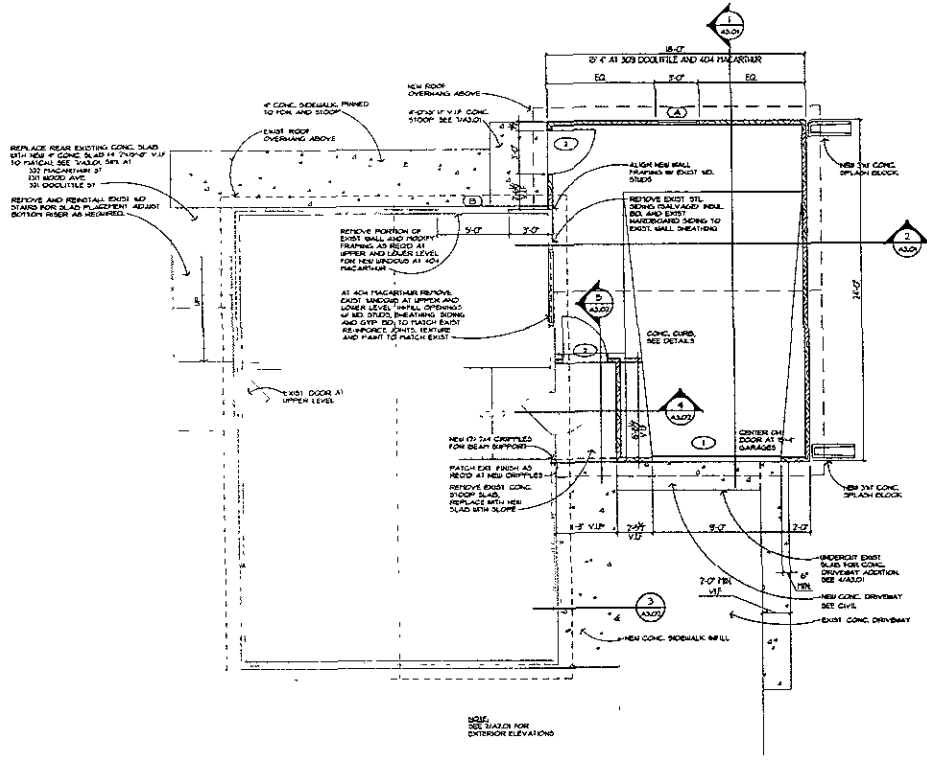

1
A101 TYPE "B" ATTACHED GARAGE PLAN
14'-11" x 11'-0"
3/4" GRIDDED ST
309 DOOLITTLE ST - 5ND ALT * 4
134 WOOD AVE
122 MACARTHUR ST
404 MACARTHUR ST - 5ND ALT * 3

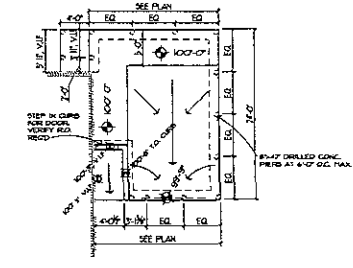

2
A102 FOUNDATION PLAN
14'-0" x 11'-0" TYPE "B" GARAGE
SLAB DRAINAGE NOTES:
1. PORTION OF SLAB IS LEVEL AT ELEV. 100'-0" EXCEPT OVERHEAD DOOR IS AT 99'-0"
2. BARRY SLAB TO IT DROWS TO THE MOULD AND OUT UNDER THE OVERHEAD DOOR

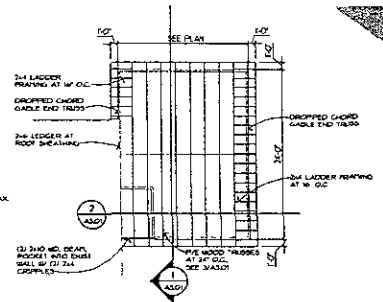

3
A103 ROOF FRAMING PLAN
14'-0" x 11'-0" TYPE "B" GARAGE
NOTE:
1. SEE A101 SH1 FOR ROOF FRAMING AT 404 MACARTHUR

PENNINGTON CO. HOUSING
 2009 CAPITAL IMPROVEMENTS - GARAGES
 MACARTHUR ST - WOOD AVE - DOOLITTLE ST
 JOB NUMBER 09-1394-001
 DATE 09/26/09
 SOUTH DAKOTA
 RAPID CITY, SOUTH DAKOTA
 ARCHITECTURE ENGINEERING
 GIS SURVEYING
 517 7th Street Rapid City, SD 57701
 PH: 605.342.9470 Fax: 605.342.9377
 www.afrcorp.com
 Copyright 2009. All rights reserved. No part of this document may be reproduced in any form or by any means without permission from Pennington Co. Design, Inc.