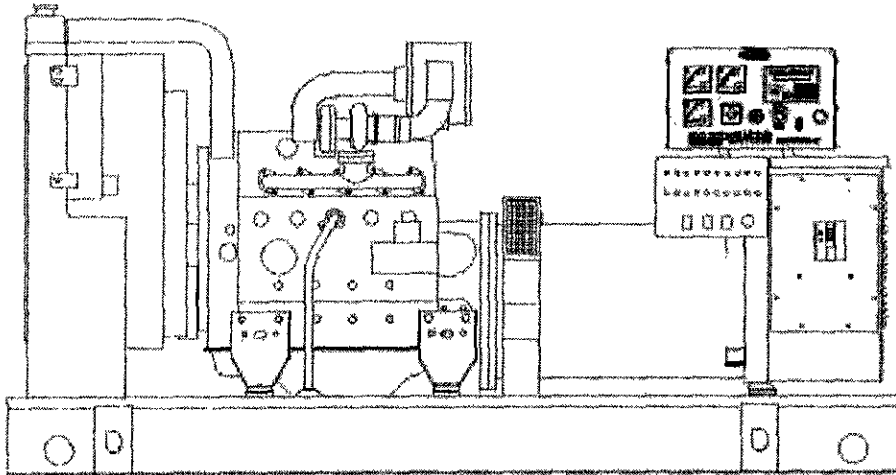

RECEIVED

JUN 10 2005

Rapid City Growth
Management Department**SD030****Liquid Cooled Diesel Engine Generator Sets**Standby Power Rating
30KW 60 HzPrime Power Rating
24KW 60 Hz

Power Matched

DEERE 2.4 DTA ENGINE

Turbocharged

VERIZON WIRELESS

30 kW Diesel Models:

04810 120/240 1 phase Open Unit

04811 120/240 1 phase Level II Enclosure

04870 120/208 3 phase Open Unit

04871 120/208 3 phase Level II Enclosed

FEATURES

- **INNOVATIVE DESIGN & PROTOTYPE TESTING** are key components of GENERAC'S success in "IMPROVING POWER BY DESIGN." But it doesn't stop there. Total commitment to component testing, reliability testing, environmental testing, destruction and life testing, plus testing to applicable CSA, NEMA, EGSA, and other standards, allows you to choose GENERAC POWER SYSTEMS with the confidence that these systems will provide superior performance.
- **TEST CRITERIA:**
 - ✓ PROTOTYPE TESTED
 - ✓ SYSTEM TORSIONAL TESTED
 - ✓ ELECTRO-MAGNETIC INTERFERENCE
 - ✓ NEMA MG1-22 EVALUATION
 - ✓ MOTOR STARTING ABILITY
 - ✓ SHORT CIRCUIT TESTING
 - ✓ UL 2200
- **SOLID-STATE, FREQUENCY COMPENSATED VOLTAGE REGULATION.** This state-of-the-art power maximizing regulation system is standard on all Generac models. It provides optimized
- FAST RESPONSE to changing load conditions and MAXIMUM MOTOR STARTING CAPABILITY by electronically torque-matching the surge loads to the engine.
- **SINGLE SOURCE SERVICE RESPONSE** from Generac's dealer network provides parts and service know-how for the entire unit, from the engine to the smallest electronic component. You are never on your own when you own a GENERAC POWER SYSTEM.
- **ECONOMICAL DIESEL POWER.** Low cost operation due to modern diesel engine technology. Better fuel utilization plus lower cost per gallon provide real savings.
- **LONGER ENGINE LIFE.** Generac heavy-duty diesels provide long and reliable operating life.
- **GENERAC TRANSFER SWITCHES, SWITCHGEAR AND ACCESSORIES.** Long life and reliability is synonymous with GENERAC POWER SYSTEMS. One reason for this confidence is that the GENERAC product line includes its own transfer systems, accessories, switchgear and controls for total system compatibility.

GENERAC®

POWER SYSTEMS, INC.

APPLICATION & ENGINEERING DATA

JUN 10 2005

Rapid City Growth

SD030

Management Department

GENERATOR SPECIFICATIONS

TYPE	Four-pole, revolving field
ROTOR INSULATION	Class F
STATOR INSULATION	Class F
TOTAL HARMONIC DISTORTION	<5%
TELEPHONE INTERFERENCE FACTOR (TIF)	<50
ALTERNATOR	Self-ventilated and drip-proof
BEARINGS (PRE-LUBED & SEALED)	1
COUPLING	Direct, Flexible Disc
LOAD CAPACITY (STANDBY)	100%
LOAD CAPACITY (PRIME)	110%

NOTE: Emergency loading in compliance with NFPA 99, NFPA 110, paragraph 5-13.2.6. Generator rating and performance in accordance with ISO8528-5, BS5514, SAE J1349, ISO3046 and DIN6271 standards.

EXCITATION SYSTEM

<input type="checkbox"/> DIRECT	DC excitation system ✓
	Low-velocity brushes and slip rings ✓
<input type="checkbox"/> BRUSHLESS	Magnetically coupled DC current ✓
	Eight-pole exciter w/ battery-driven field boost ✓
	Mounted outboard of main bearing ✓
REGULATION	Solid-state ✓
	±1% regulation ✓

GENERATOR FEATURES

- Four pole, revolving field generator, directly connected to the engine shaft through a heavy-duty, flexible disc for permanent alignment
- Generator meets the temperature rise standards for class "F" insulation as defined by NEMA MG1-32.6, while the insulation system meets the requirements for the higher class "H" rating.
- All prototype models have passed a three-phase symmetrical short circuit test to assure system protection and reliability.
- All prototype models are tested for motor starting ability by measuring the instantaneous voltage dip with a waveform data acquisition system.
- All models utilize an advanced wire harness design for reliable interconnection within the circuitry.
- Magnetic circuit, including amortisseur windings, tooth and skewed stator design, provides a minimal level of waveform distortion and an electromagnetic interference level which meets accepted requirements for standard AM radio, TV, and marine radio telephone applications
- Voltage waveform deviation, total harmonic content of the AC waveform, and TIF. (Telephone Influence Factor) have been evaluated to acceptable standards in accordance with NEMA MG1-32
- Alternator is self-ventilated and drip-proof constructed
- Fully life-tested protective systems, including "field circuit and thermal overload protection" and optional main-line circuit breakers capable of handling full output capacity
- System Torsional acceptability confirmed during Prototype Testing

ENGINE SPECIFICATIONS

MAKE	DEERE
MODEL	2 4DT
CYLINDERS	4 in-line
DISPLACEMENT	2.4 Liter (149 cu in.)
BORE	86 mm (3.39 in.)
STROKE	105 mm (4.13 in.)
COMPRESSION RATIO	18:1
INTAKE AIR	Turbocharged
NUMBER OF MAIN BEARINGS	5
CONNECTING RODS	4-Drop forged steel
CYLINDER HEAD	Cast iron w/ overhead valve
PISTONS	4-Aluminum alloy
CRANKSHAFT	Forged Steel

VALVE TRAIN

LIFTER TYPE	Solid
INTAKE VALVE MATERIAL	High Temp
EXHAUST VALVE MATERIAL	High Temp

ENGINE GOVERNOR

<input type="checkbox"/> ELECTRONIC	Standard
FREQUENCY REGULATION, NO-LOAD TO FULL LOAD	±0.5%
STEADY STATE REGULATION	±0.25%

LUBRICATION SYSTEM

TYPE OF OIL PUMP	Gear
OIL FILTER	Full flow, cartridge
CRANKCASE CAPACITY	7.5 qts

COOLING SYSTEM

TYPE OF SYSTEM	Pressurized, closed recovery
WATER PUMP	Pre-lubed, self-sealing
TYPE OF FAN	Pusher
NUMBER OF FAN BLADES	6
DIAMETER OF FAN	457.2 mm (18.0 in.)
COOLANT HEATER	120V, 1000 W

FUEL SYSTEM

FUEL	#2D Fuel (Min Cetane #40)
	(Fuel should conform to ASTM Spec)
FUEL FILTER	10 Micron
FUEL INJECTION PUMP	Bosch (VE)
FUEL PUMP	Engine Driven Gear Type
INJECTORS	Pintel Type, 2100 PSI
ENGINE TYPE	Pre-combustion, swirl chamber
FUEL LINE (Supply)	6.35 mm (0.25 in.)
FUEL RETURN LINE	3.17 mm (0.125 in.)

ELECTRICAL SYSTEM

BATTERY CHARGE ALTERNATOR	42 Amps at 12 V
STARTER MOTOR	12 V 290A @ 0 °C
RECOMMENDED BATTERY	(1) - 12 V, 90 A.H., 27F
GROUND POLARITY	Negative

Rating definitions - Standby: Applicable for supplying emergency power for the duration of the utility power outage. No overload capability is available for this rating. (All ratings in accordance with BS5514, ISO3046 and DIN6271) Prime (Unlimited Running Time): Applicable for supplying electric power in lieu of commercially purchased power. Prime power is the maximum power available at variable load. A 10% overload capacity is available for 1 hour in 12 hours. (All ratings in accordance with BS5514, ISO3046, ISO8528 and DIN6271).

SD030

OPERATING DATA

	STANDBY SD030		PRIME SD030	
GENERATOR OUTPUT VOLTAGE/KW-60Hz 120/240V, 1-phase, 1.0 pf 120/208V, 3-phase, 0.9 pf	NOTE: Consult your generator dealer for additional voltages		Rated AMP 25 104 30 104	
MOTOR STARTING KVA Maximum at 35% instantaneous voltage dip with optional alternator, 60 Hz	120/208/240V 69		120/208/240V 69	
FUEL Fuel consumption—60 Hz Load gal./hr liters/hr Fuel pump lift	100% 2.5 9.5	80% 2.1 7.9	100% 2.1 7.9	80% 1.8 6.8
COOLING Coolant capacity System - lit (US gal.) Engine - lit (US gal.) Coolant flow/min 60 Hz - lit (US gal.) Heat rejection to coolant 60 Hz full load BTU/hr. Inlet air to radiator 60 Hz - m ³ /min. (cfm) Max. air temperature to radiator °C (°F) Max. ambient temperature °C (°F)	11.2 (30) 2.6 (0.7) 8.6 (2.3) 120,000 130 (4,600) 60 (140) 46.9 (120)		11.2 (30) 2.6 (0.7) 8.6 (2.3) 96,000 130 (4,600) 60 (140) 48.9 (120)	
COMBUSTION AIR REQUIREMENTS Flow at rated power 60 Hz - cfm	109		83	
EXHAUST Exhaust flow at rated output 60 Hz - m ³ /min (cfm) Max recommended back pressure °Hg Exhaust temperature 60 Hz (full load) °C (°F) Exhaust outlet size	8.9 (316) 1.5 549 (1100) 8.0" O.D.		7.2 (263) 1.5 510 (1010) 8.0" O.D.	
ENGINE Rated RPM 60 Hz HP at rated KW 60 Hz Piston speed 60 Hz - m/min (ft/min.) BMEP 60 Hz - psi	1800 48 378 (1259) 144		1800 39 378 (1239) 118	
DERATION FACTORS Temperature 5% for every 10°C above - °C 2.77% for every 10°F above - °F Altitude 1.1% for every 100 m above - m 3.5% for every 1000 ft above - ft.	85 77 1067 3500		25 77 1067 3500	

RECEIVED

JUN 10 2005

 Rapid City Growth
 Management Department

STANDARD ENGINE & SAFETY FEATURES

SD030

- High Coolant Temperature Automatic Shutdown
- Low Coolant Level Automatic Shutdown
- Low Oil Pressure Automatic Shutdown
- Overspeed Automatic Shutdown (Solid-state)
- Crank Limiter (Solid-state)
- Oil Drain Extension
- Radiator Drain Extension
- Factory-installed Cool Flow Radiator
- Closed Coolant Recovery System
- UV/Ozone Resistant Hoses
- Rubber-Booted Engine Electrical Connections
- Secondary Fuel Filter
- Fuel Shutdown Solenoid
- Batteries 2 - 12 Volt 90 AH
- Stainless Steel Flexible Exhaust Connection
- Battery Charge Alternator
- Battery Cables
- Composite Battery Box
- Vibration Isolation of Unit to Mounting Base
- 24 Volt, Solenoid-Activated Starter Motor
- Air Cleaner
- Air Cleaner Service Indicator
- Fan Guard (CSA Compliant)
- CSA Guarding
- Critical Grade Muffler (Shipped Loose With Open Unit)
- High Temperature Exhaust Wrap
- Alternator Tropicalization
 - Resists Moisture, Fungus and Abrasives
 - In Addition to Standard Class H Epoxy Impregnation Coating
- Upoized Alternator For Increased Motor Starting
- Propylene Glycol 50/50 Mix Antifreeze
- Oil (19.0 Quarts)
- Coolant Expansion and Recovery Tank
- Extended Factory Test (2.5 Hr.)
 - Stepped Loads
 - Frame Temperature Test
- Specification Sheet Does Not Reflect Any Verizon Wireless Corporate Authorized Variances
- "E" Control Console - Digital/Analog Hybrid
 - Communication Software for Remote Access
 - Analog Reading AC Volts
 - Analog Reading AC Amps
 - Analog Frequency
 - Emergency Stop Button

- Audible Alarm
 - 11 Gauge Control Panel Enclosure
 - Programmable Engine Control (See Bulletin #01613105BY For Details)
 - 20 Light Annunciator Generator Alarms
 - 8 Form C Dry Contact Output Relays
 - 120 Volt Coolant Heater 1800 Watt with 3 Wire Connection Cord
 - Mainline Circuit Breaker
 - 200 Amp & 100 Amp - 120/240 Single Phase
 - 200 Amp & 50 Amp - 120/208 Three Phase
 - Flexible Fuel Lines
 - Fuel Pressure Loss Protection System
 - UL2200 Listed
 - Basotank
 - 48 Hr Runtime at 100% Load
 - Double Wall
 - 125% Engine Fluid Containment and Alarms of all Generator Liquids
 - Fuel Level Sender and Visible Level Gauge
 - Rupture Basin Alarm
 - Emergency Vents
 - Check Valve (inlet and return)
 - FM Fusible Link (165°F) Shutoff
 - UL 142 Listed
 - Washington State maximum of 114 gallons
 - Southern California limitation of 52 gallons
- Consult State and Local Codes for Specific Requirements in your area.
- Five Year Extended Warranty
 - Enclosure Options
 - Open Generator Set w/ Dual Adapter
 - Weather Protective Sound Attenuated Enclosure w/ Enclosed Critical Grade Muffler and Flex Exhaust
 - 24V Dual-Rate 10 Amp Battery Charger With 120V 3 Wire Connection Cord

Distributed by:

RECEIVED

JUN 10 2005

Rapid City Growth
Management Department

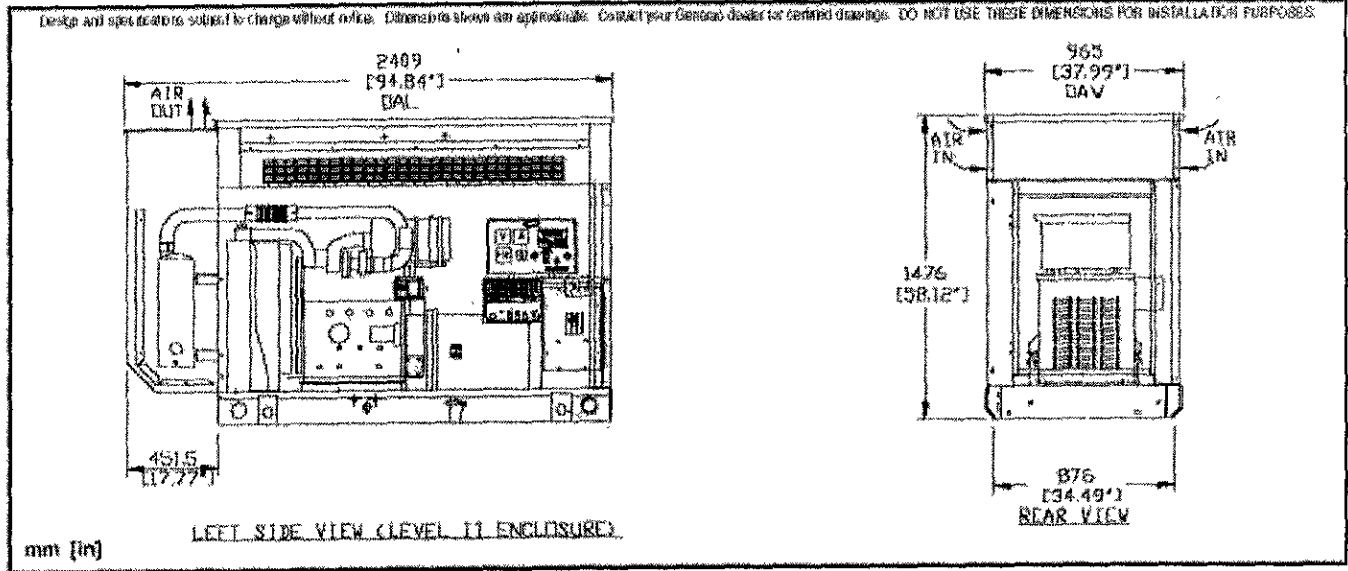

GENERAC POWER SYSTEMS, INC. • P.O. BOX 8 • WAUKESHA, WI 53187
 262/544-4811 • FAX 262/544-4851

0F0835

05SR035

NOTES

JUN 10 2005

EM
Rapid City Growth
Management Department

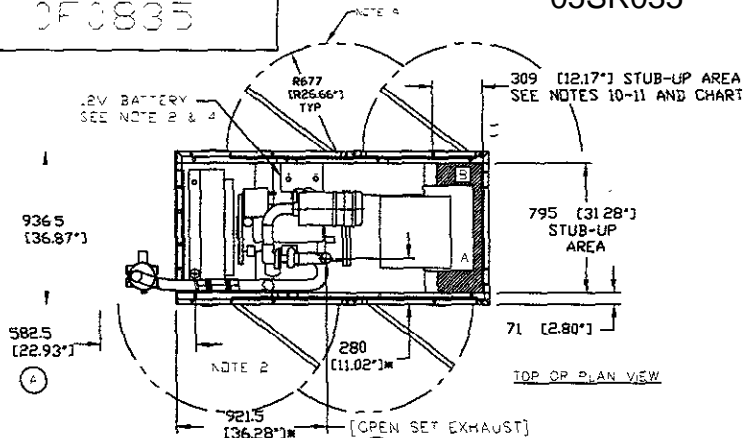

RECOMMENDED ELECTRICAL STUB-UPS (SEE TOP VIEW)	
DESCRIPTION	INSIDE BASE
NO LOAD LEAD CONDUIT (50A)	A
120/240V AC FOR BATTERY CHARGER AND BLOCK HEATER	B
AC LOAD LEAD CONDUIT HOOK-UP	<input checked="" type="checkbox"/>

ENGINE SERVICE CONNECTIONS

FUEL INLET & RETURN = 1/4" NPT COUPLING
 OIL & RADIATOR DRAINS = 1/2" NPT COUPLING
 EXHAUST OUTLET - 2 - 1/2" OD EXHAUST ELBOW AS SHOWN ON OPEN SET
 2-1/2" OD MUFFLER OUTLET WITH COMPARTMENT

OR 25A-3 PHASE CIRCUIT BREAKER

NOTE

UNIT IS SHIPPED WITH FUEL SUPPLY AND RETURN LINES DISCONNECTED AND PLUGGED BETWEEN ENGINE AND FUEL TANK THIS HAS BEEN DONE TO FACILITATE PRESSURE TESTING OF THE TANK IN THE FIELD FOR INFORMATION REGARDING CONNECTING THE FUEL SUPPLY AND RETURN LINES PRIOR TO START UP. SEE THE FUEL TANK FIELD TESTING PROCEDURE SUPPLIED IN THE TANK LOOSE JENTS KIT WHICH IS SHIPPED WITH THIS GENERATOR

**DIMENSIONS ARE FOR BASE MOUNTING LOCATIONS

WEIGHT DATA

OPEN SET UNIT 607 kg [1336 lbs] (WET)
 TANK 338 kg [745 lbs]
 STEEL COMPARTMENT ESTIMATED 341 kg [752 lbs]

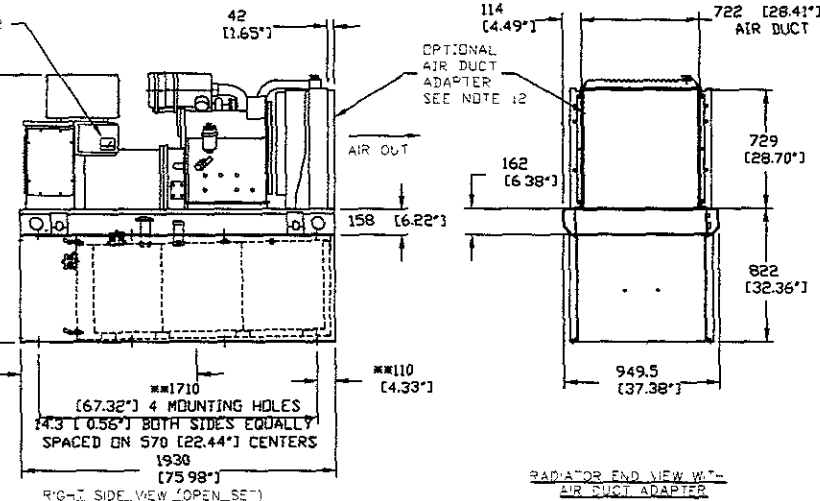
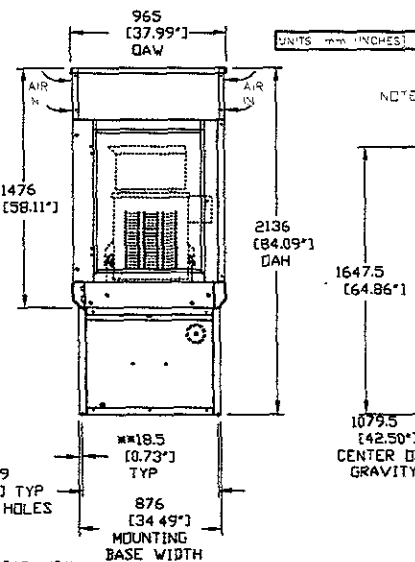
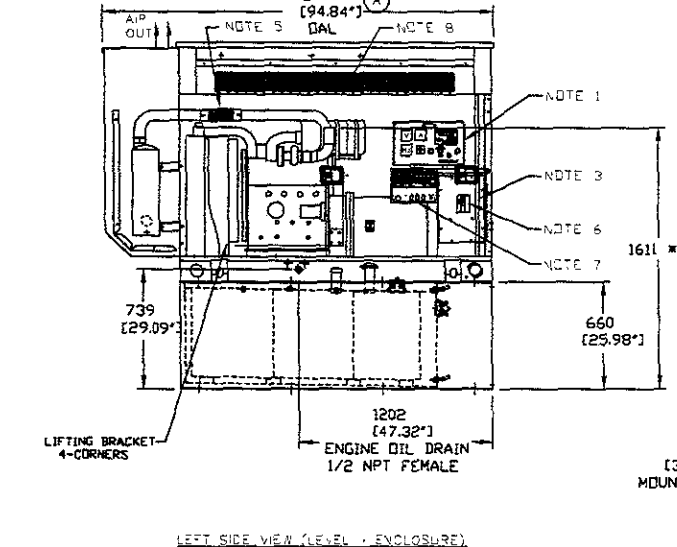

GENERAL POWER SYSTEMS OWNS THE COPYRIGHT OF THIS DRAWING WHICH IS SUPPLIED IN COMPLETE AND MUST NOT BE USED FOR ANY PURPOSE OTHER THAN FOR WHICH IT IS SUPPLIED WITHOUT THE EXPRESS WRITTEN CONSENT OF GENERAL POWER SYSTEMS.
 © GENERAL POWER SYSTEMS 2011

EST. WT	
FINAL WT	
DO NOT SCALE	
ALL DIMENSIONS AND TOLERANCES PER ASME Y14.5M-1994	
UNLESS OTHERWISE SPECIFIED	
ALL XX DIM. --- 2- W	
ALL XX DIM. --- 2- W	
ALL XX DIM. --- 2- W	
ALL ANGLES --- 2-	
RELEASED PER PRODUCTION	BY 3 BAIRD
DATE	3/2/04

DRAWING TITLE		INSTALL DWG, 30kW VERIZON DIESEL LBA ENCL	
MATERIAL		N/A	
DWN	RS	DATE	2/23/04
APPD	BOB	DATE	3/2/04
SCALE	1 = 40	REV	1
FILE NAME	0F0835-A.DWG	DATE	3/2/04
SCALE	1 = 40	REV	1

5/1/04	3-2964-A	ADDED OVERALL LENGTH DIM AND UPDATED OTHER MISCL INFO SEE ECU
--------	----------	---

0F0835