

3/4" SINGLE REFLECTOR  
GOOSENECK WALL BRACKET  
ABSOLUTE GB BR/INT  
ABSOLUTE ANGLE REFLECTOR  
W/ TON MED. BASE  
JPL METAL HALIDE LAMP  
FOR OUTDOOR FIXTURE  
LAMP FIXTURE AND EXT. SUPPORT'S  
PTD #313 BRONZE

NOTE: CLOSURE VELY TO BE FIELD  
OUT AND PLS. RENEW BY FEDERAL  
HEATH SIGN COMPANY

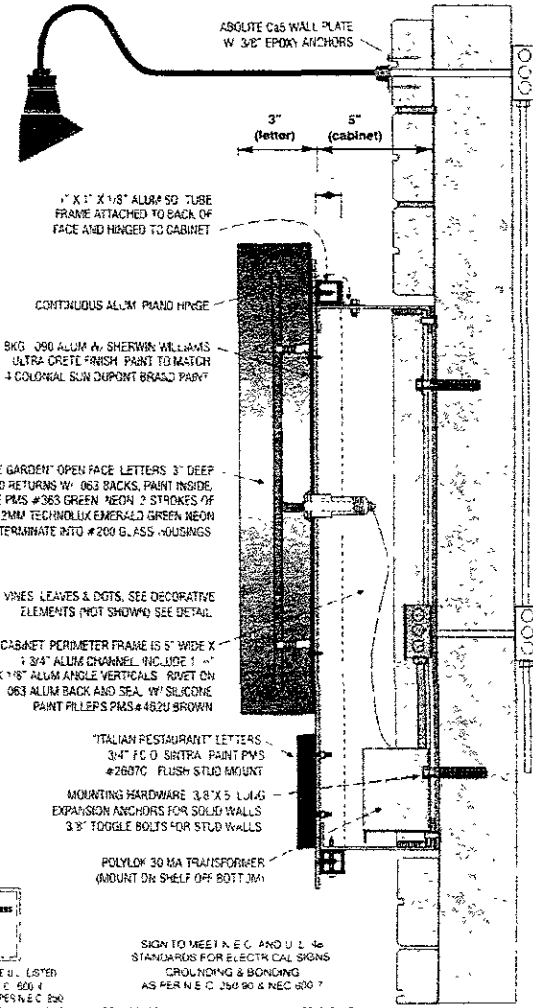

1" X 1" X 1/8" ALUM. SQ. TUBE  
FRAME ATTACHED TO BACK OF  
FACE AND HINGED TO CABINET

CONTINUOUS ALUM. PRIMO HINGE

FACE BKG. 390 ALUM. W/ SHERWIN WILLIAMS  
ULTRA GREY FINISH PAINT TO MATCH  
51-4 COGNAC SUN DUPONT BRASS PAINT

'OLIVE GARDEN' OPEN FACE LETTERS 3" DEEP  
030 RETURNS W/ 063 BACKS, PAINT INSIDE.  
OUTSIDE PMS #363 GREEN NEON 2 STROKES OF  
12MM TECHNOLUX EMERALD GREEN NEON  
TO TERMINATE INTO #200 G. ASS. HOUSINGS

VINES, LEAVES & DGTS. SEE DECORATIVE  
ELEMENTS (NOT SHOWN) SEE DETAIL

CABINET PERIMETER FRAME IS 5" WIDE X  
3/4" ALUM. CHANNEL. INCLUDE 1" X  
1" X 1/8" ALUM. ANGLE VERTICALS. RIVET ON  
063 ALUM. BACK AND SEA. W/ SILICONE  
PAINT PILLES PMS #482U BROWN

'ITALIAN RESTAURANT' LETTERS  
3/4" FC O. SIBTRA. PAINT PMS  
#2670C. FLUSH STUD MOUNT

MOUNTING HARDWARE 3/8" X 5/16" LUGS  
EXPANSION ANCHORS FOR SOLID WALLS  
3/8" TIGGLE BOLTS FOR STUD WALLS

POLYLOK 30 MA TRANSFORMER  
(MOUNT ON SHELF OFF BOT. JM)

SIGN TO MEET N.E.C. AND U.L. 98  
STANDARDS FOR ELECTRICAL SIGNS  
CROWLING & BONDING  
AS PER N.E.C. 250.90 & NEC 600.7

PRIMARYS AND FINAL CONNECTION TO SIGN BY  
CERTIFIED ELECTRICIAN

**ELECT. REQMTS**

(2) 120V-1120S 13.66 AMPS  
(1) 320-3912S 2.48 AMPS  
TOTAL AMPS 16.14 120V 20A

U.L. LABELS REQ. AWAY  
FROM PUBLIC VIEW

**IMPORTANT NOTE:**

A 2161 COMB. UNIT  
PER NEC AND MANUFACT. INSTRUCTIONS  
RECOMMENDATIONS. ALL ELECTRICAL  
PRIMER TECHNICIANS MUST BE  
PROFICIENT IN THE USE OF

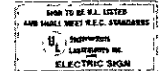

ALL ELECTRICAL COMPONENTS TO BE U.L. LISTED  
APPROVED AND MARKED PER N.E.C. 600.4  
ALL TO BE ELECTRICALLY GROUND PER N.E.C. 250  
ALL POWER SUPPLIES TO BE PLS. PER U.L. 98 28.2  
GROUNDING AND BONDING PER U.L. 98 94.96

**DETAILED END VIEW**  
SCALE N.T.S.



Other Cities Offered Locally:	Company #
Cincinnati, Las Vegas, Sacramento	
Kansas City, Milwaukee	
Houston, San Antonio, Corpus Christi	
Milwaukee, Indianapolis, Austin, Tampa, Daytona Beach	
Building Quality Signs for American Business	Chief Order Val/Clerk

Account Rep	M. SCHAEFER
Project Manager	S. BRANDON
Order by	DENNIS RADTKE
File Name	



Job #	2-2-05
Job Name	5 of 8
Design Number	T05863

This sign drawing is provided as part of a contract project and shall not be exhibited, copied, re-produced, or otherwise used without the written permission of Federal Heath Sign Company. 1/1/05

**APPROVED**  
By Gregg Soltis at 8:50 am, 3/14/05

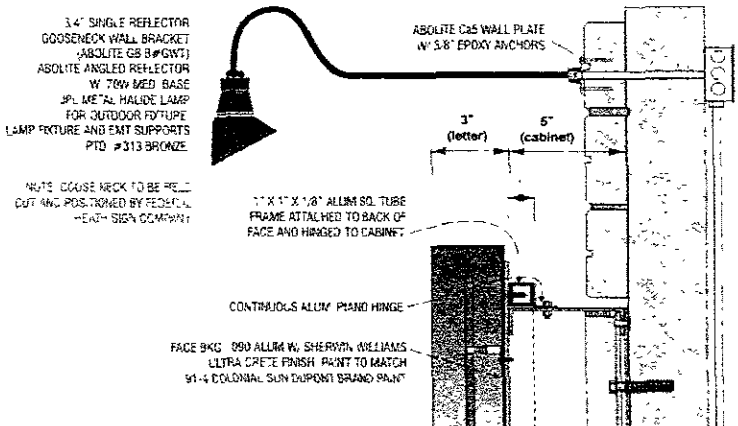
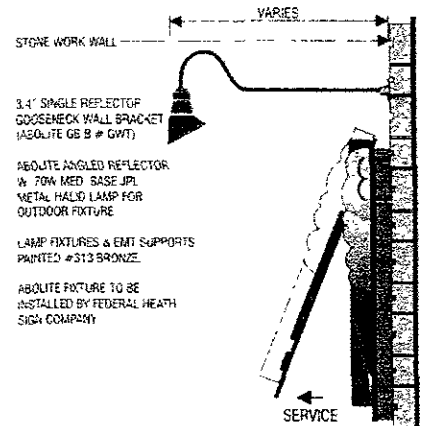

OG-SIG-W65SLIM-OCL S/F WALL SIGN 65 SQ. FT SCALE 3/8" = 1' 0"

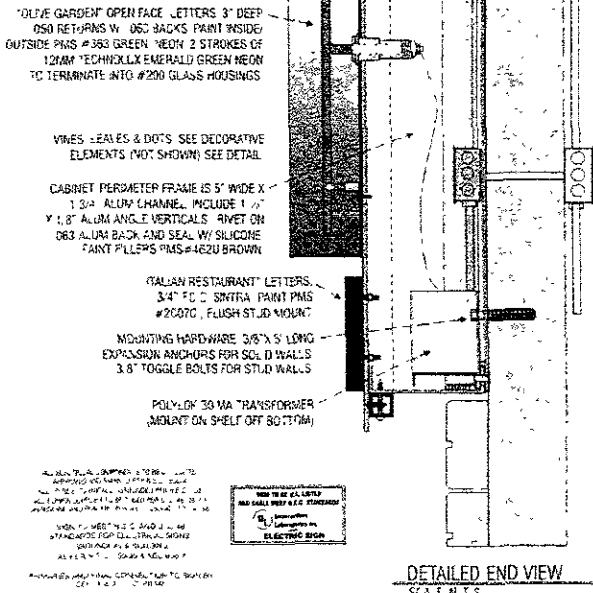
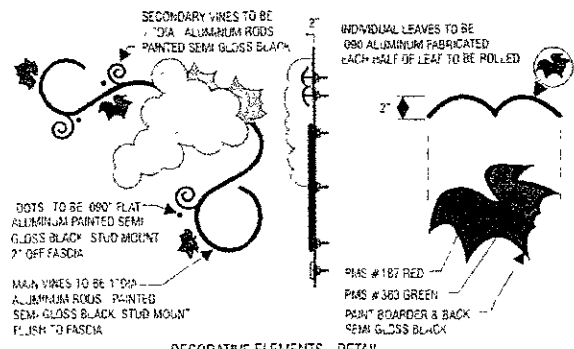
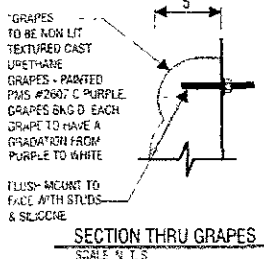
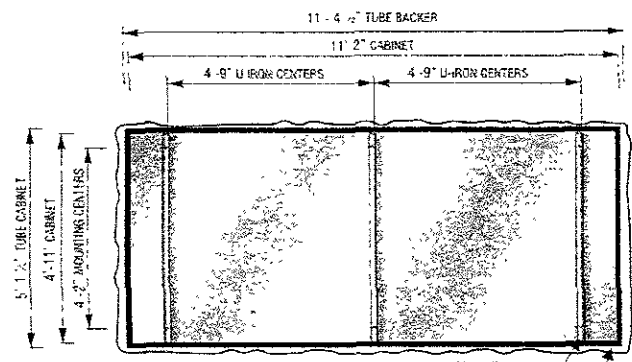

**ELECT. REQMTS**

IG: 12/30 - 112126 @ 3 J AMPS EA  
 TOTAL AMPS = 9 @ 11, 120 V 20 A  
 U.L. LABELS REQ'D AWAY FROM PUBLIC VIEW

**IMPORTANT NOTE:**

UL 2161 COMPLIANT  
 PER NEG AND MANUFACTURING RECOMMENDATIONS ALL ELECTRICAL PRIMARY CIRCUITS MUST BE DEDICATED ISOLATED CIRCUITS

**FEDERAL HEALTH SIGN COMPANY**  
 www.federalhealth.com  
 1557 Compton Ave. (at 14th St.)  
 Los Angeles, CA 90019

OUR PRODUCTS ARE MADE IN THE U.S.A.  
 FEDERAL HEALTH SIGN COMPANY  
 1557 Compton Ave. (at 14th St.)  
 Los Angeles, CA 90019

DATE	DESCRIPTION

DATE	MARK SCHAEFER
DATE	STEVE BRANDON
DATE	DENNIS RADTKE
DATE	
DATE	

OLIVE GARDEN  
 RAPID CITY, SD

DATE	2-2-05
DATE	6-1-08
PROJECT NO.	T05863

THIS SIGN IS THE PROPERTY OF FEDERAL HEALTH SIGN COMPANY AND IS TO BE USED ONLY FOR THE PURPOSES SPECIFIED IN THE CONTRACT. ANY OTHER USE IS STRICTLY PROHIBITED. FEDERAL HEALTH SIGN COMPANY IS NOT RESPONSIBLE FOR THE CONTENTS OF ANY SIGNAGE.

**APPROVED**  
 By Gregg Soltis at 8:50 am, 3/14/05

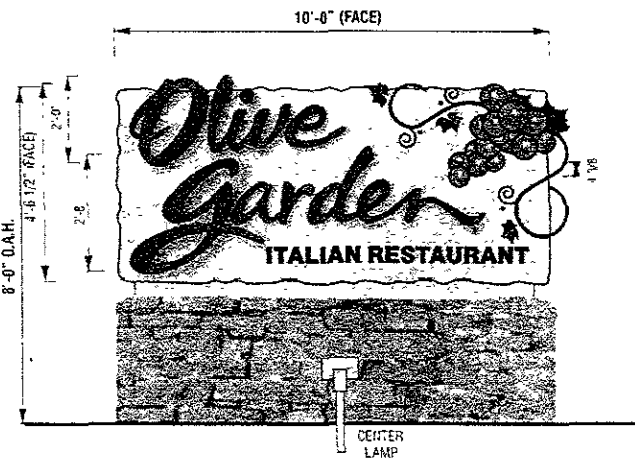

**D** OG-SIG-M50-CH D/F MONUMENT  
(1) REQUIRED  
SIGN 50 50 FT  
SCALE 3/8" = 1'-0"

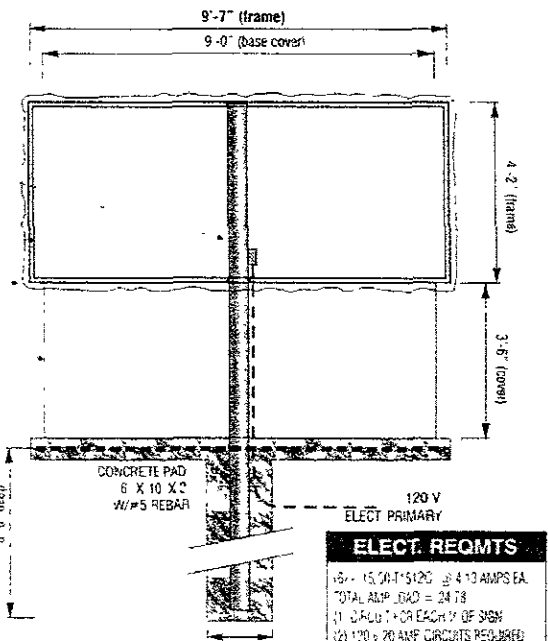
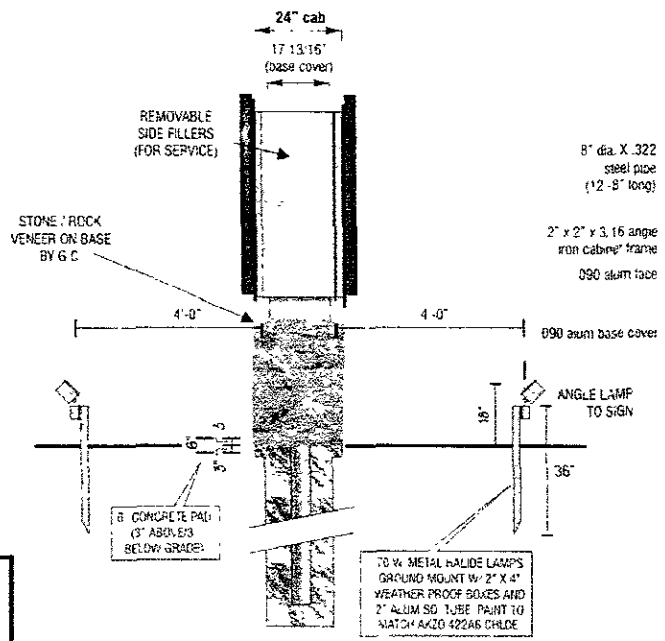

**ELECT. REQMTS**

18" - 15, 20, 25, 30, 40, 50 @ 4.10 AMPS EA.  
TOTAL AMP LOAD = 24.75  
(1) CIRCUIT FOR EACH 1/2 OF SIGN  
(2) 120 V 20 AMP CIRCUITS REQUIRED  
ELECT. LABELS REQ'D AWAY FROM PUBLIC VIEW

**IMPORTANT NOTE:**

UL 1587 COMPLIANT PER N.E.C. MANUFACTURING RECOMMENDATIONS ALL ELECTRICAL PRIMARY CIRCUITS MUST BE DECONTACTED ISOLATED CIRCUITS.



ALL ELECTRICAL COMPONENTS TO BE UL LISTED APPROVED AND MARKED PER N.E.C. 90A-4 ALL TO BE ELECTRICALLY GROUND PER N.E.C. 250 A. POWER SUPPLIES TO BE FUSED PER U.L. 48 78 2" GROUNDING AND BONDING PER N.E.C. 250-50 - 92-34 59 SIGN TO MEET N.E.C. AND U.L. 48 STANDARDS FOR ELECTRICAL SIGNS GROUNDING & BONDING AS PER N.E.C. 90-40 & N.E.C. 600 7

PRIMARIES AND FINAL CONNECTION TO SIGN BY CERTIFIED ELECTRICIAN

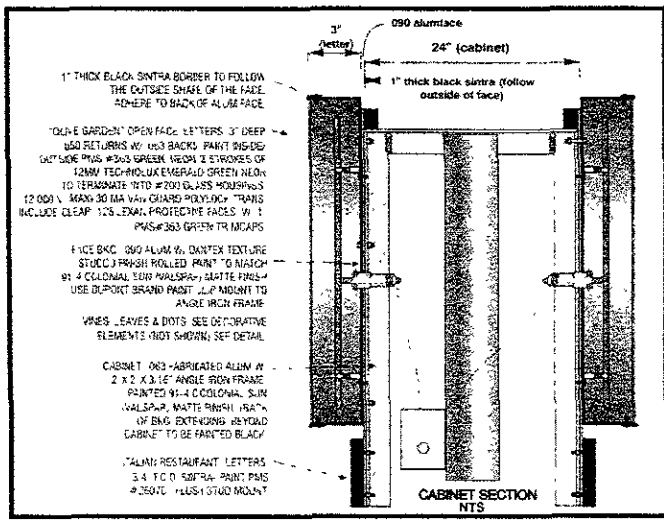

CABINET SECTION NTS

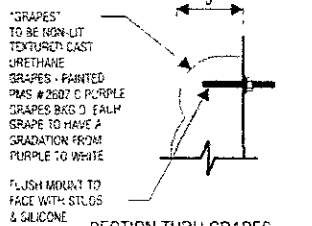

SECTION THRU GRAPES SCALE N T S

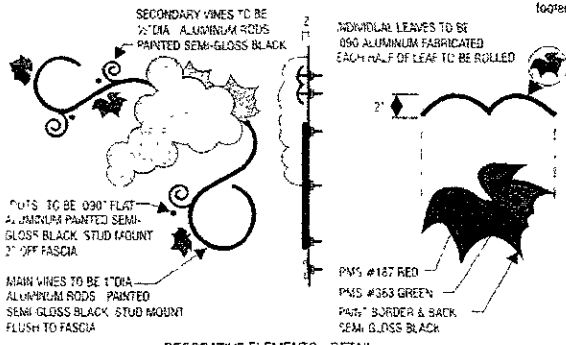

DECORATIVE ELEMENTS - DETAIL SCALE N T S

**FEDERAL HEATH SIGN COMPANY**  
www.federalheath.com  
10000 Santa Fe Blvd, Suite 100, Denver, CO 80231  
303.751.1100

OUR OFFICES ARE LOCATED IN:  
Denver • Houston • San Antonio  
Chicago • Dallas • Milwaukee  
Austin • Atlanta • Daytona Beach  
Building County, Colorado Springs, Denver, Fort Collins, Grand Junction, Pueblo, Steamboat Springs, Vail, and Wood Dale

OWNER	MARK SCHAEFER
DESIGNER	STEVE BRANDON
INSTALLER	DENNIS RADTKE
DATE	

PROJECT	OLIVE GARDEN RAPID CITY, SD
DATE	2-2-05
SCALE	7" x 8"
DRAWING NO.	T05863

**OLIVE GARDEN**  
RAPID CITY, SD  
*Olive Garden*

DATE	2-2-05
SCALE	7" x 8"
DRAWING NO.	T05863

**APPROVED**  
By Gregg Soltis at 8:50 am, 3/14/05

