

# EVERGREEN TOWNHOMES & APARTMENTS

PREPARED FOR  
BOBBY AND GENAE SUNDBY

JANUARY 2005

VICINITY MAP (NTS)

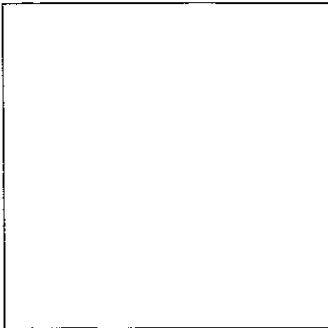

### INDEX

SHEET 1 - TITLE PAGE  
SHEET 2 - TOPOGRAPHIC MAP  
SHEET 3 - LAYOUT PLAN  
SHEET 4/5 - PLAN & PROFILES  
SHEET 7 - GRADING PLAN  
SHEET 8 - ROAD CROSS SECTIONS  
SHEET 9 - DETAILS

### LEGEND

--- 3310 ---	1' CONTOUR INTERVAL
--- 3310 ---	5' CONTOUR INTERVAL
--- 3340 ---	PROPOSED CONTOUR INTERVAL
=====	STREET CENTERLINE
=====	PROPERTY LINE
=====	EXISTING EASEMENT LINE
=====	PROPOSED EASEMENT LINE
----- 96 -----	EXISTING WATER LINE
----- 96 -----	PROPOSED WATER LINE
----- 58 -----	EXISTING SANITARY SEWER LINE
----- 58 -----	PROPOSED SANITARY SEWER LINE
----- 3318 -----	EXISTING STORM SEWER LINE
----- 3318 -----	PROPOSED STORM SEWER LINE
----- 09P -----	OVERHEAD POWER LINE
---X---X---X---	FENCE LINE (CHAIN LINK & WOOD)
▲ CP 01	CONTROL POINT (SET FOR THIS SURVEY)
●	FOUND PROPERTY CORNER
○ MH	MANHOLE (SANITARY OR STORM SEWER)
● FH	FIRE HYDRANT
● WV	WATER VALVE
○	POWER POLE
○	QUI ANCHOR
+ 78	TELEPHONE JUNCTION BOX
√ 3500 0	SPOT ELEVATION
⊗	BUSHES
⊗	TREES

### UTILITY NOTE

THE LOCATIONS OF ANY EXISTING UTILITIES SHOWN HEREON ARE IN AN APPROXIMATE WAY ONLY AND HAVE NOT BEEN INDEPENDENTLY VERIFIED. EXACT LOCATIONS OF UTILITIES SHALL BE DETERMINED BY THE OWNER, CONTRACTOR OR THE OWNER'S REPRESENTATIVE PRIOR TO ANY CONSTRUCTION. NOTIFY SOUTH DAKOTA ONE CALL CENTER: 1-800-781-7474

### ENGINEER/SURVEYOR CERTIFICATE

I HEREBY CERTIFY THAT THESE PLANS WERE PREPARED UNDER MY SUPERVISION AND THAT I AM DULY REGISTERED UNDER THE LAWS OF THE STATE OF SOUTH DAKOTA.

STEVEN D. THIMMELSTAD SD NO. 4371

PREPARED BY:  
BRITTON ENGINEERING AND LAND SURVEYING, INC.  
11750 N. HIGHWAY 79 ~ BLACK HAWK, SD PH. (605) 716-7988

# RECEIVED

MAR 24 2005

Rapid City Growth  
Management Department

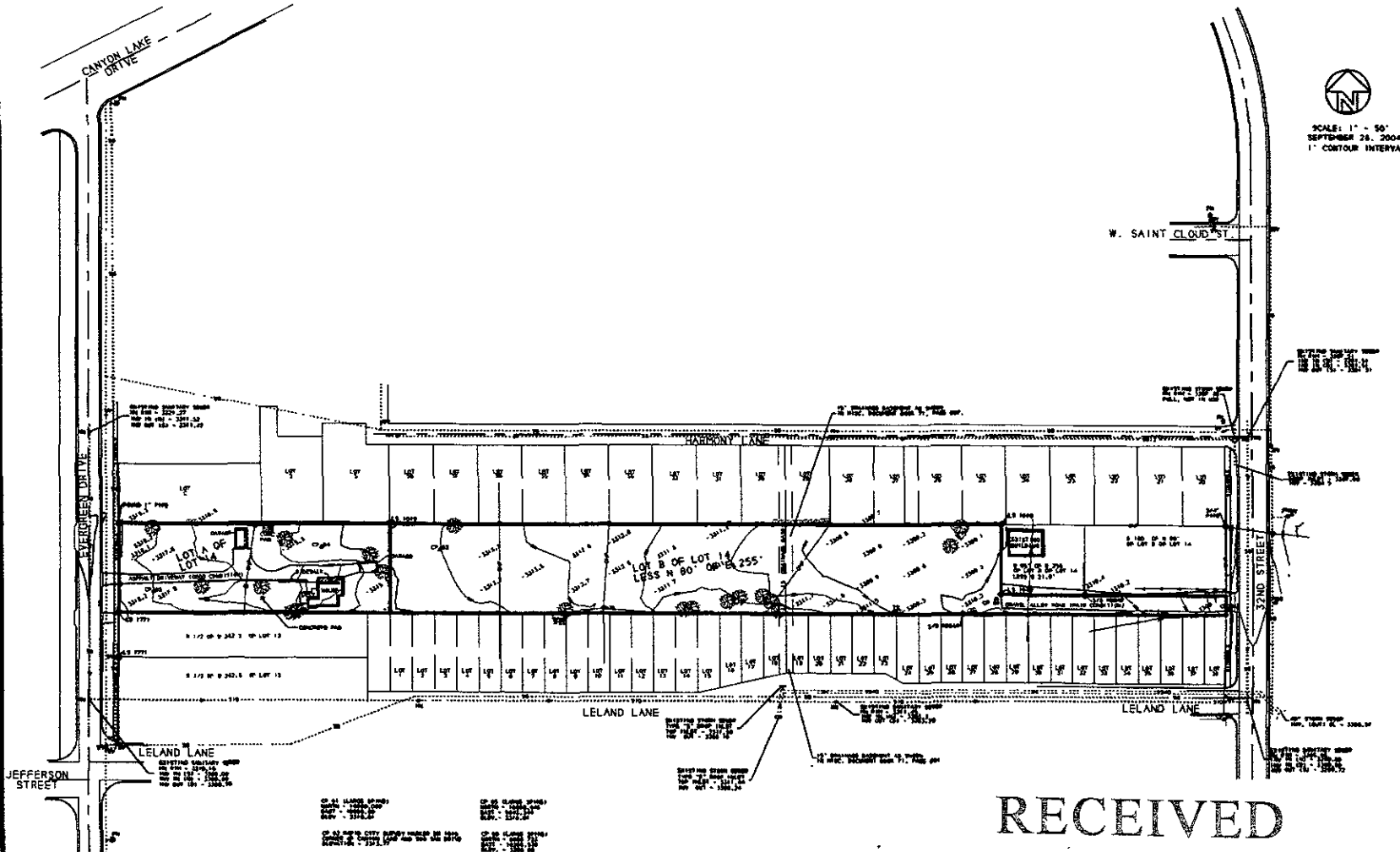

SCALE: 1" = 50'  
 SEPTEMBER 28, 2004  
 1" CONTOUR INTERVAL

BRITTON ENGINEERING & LAND SURVEYING, INC.  
 11750 N. HIGHWAY 79  
 BLACK HAWK, SD 57718  
 PH. (605) 716-7988

LOT A & LOT B OF 14 LESS N 80'  
 OF E 255 OF LOT B, PLATTED,  
 SEC 4, T1N, R7E, BHM, RAPID CITY  
 PENNINGTON COUNTY, SOUTH DAKOTA

TOPOGRAPHIC MAP  
 EVERGREEN TOWNHOMES & APARTMENTS  
 BOBBY AND GEVAE SUNDBY

SEE SHEET 05PD003 FOR  
 SEE SHEET 05PD004 FOR  
 SEE SHEET 05PD005 FOR  
 SEE SHEET 05PD006 FOR  
 SEE SHEET 05PD007 FOR  
 SEE SHEET 05PD008 FOR

RECEIVED

MAR 24 2005

Rapid City Growth

Management Department

2  
9

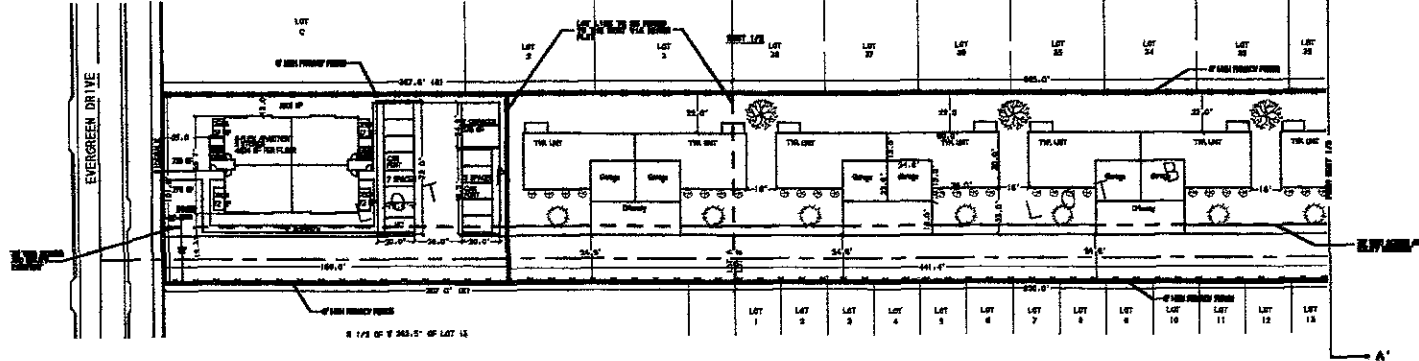

SCALE: 1" = 30'  
JANUARY 28, 2005

LANDSCAPE PLANTS SPECIFIED FOR DIVISION LOT B  
 LANDSCAPE PLANTS SPECIFIED FOR DIVISION LOT C  
 LANDSCAPE PLANTS SPECIFIED

SYMBOL	PLANT	QUANTITY	TOTAL
○	SMALL TREES (8" DBH)	10	10
○	MEDIUM TREES (12" DBH)	5	5
○	LARGE TREES (18" DBH)	2	2
○	SHRUBS (6" DBH)	20	20
○	PERENNIALS	100	100
○	TOTAL PLANTS	147	147

- LANDSCAPE PLANTS SPECIFIED
- COMMON LAWN PLANTS (8" DBH)
  - SMALL TREES (8" DBH)
  - MEDIUM TREES (12" DBH)
  - LARGE TREES (18" DBH)
  - SHRUBS (6" DBH)
  - PERENNIALS

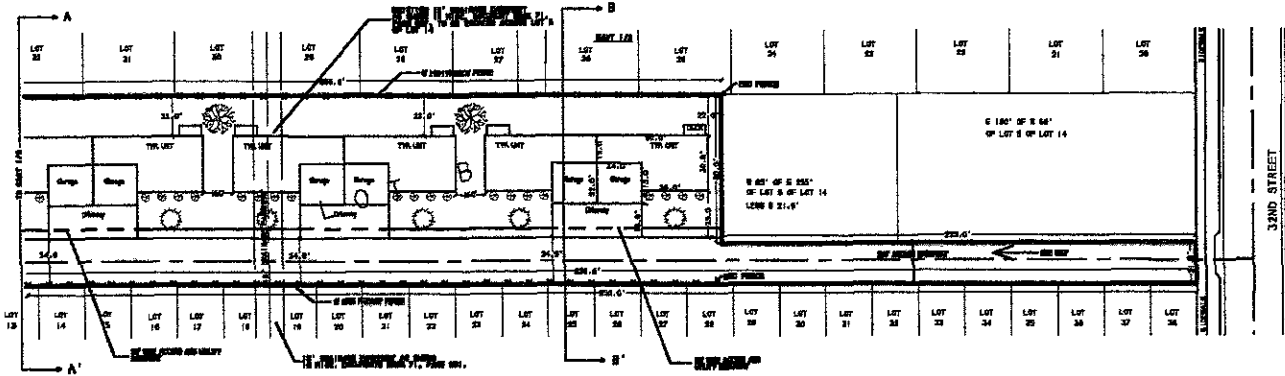

NOTE: ALL PLANTS TO BE PLANTED WITH STONE MULCH  
 MULCH TO BE PLANTED WITH STONE MULCH

RECEIVED

MAR 24 2005

Rapid City Growth Management Department

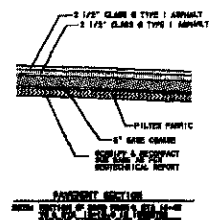
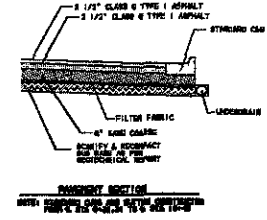
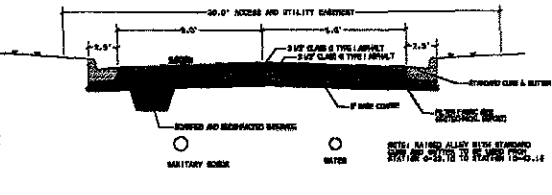
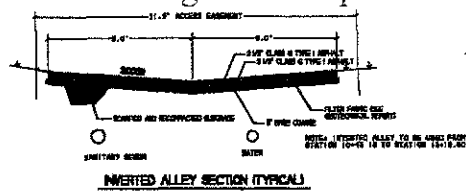

BRITTON ENGINEERS & LAND SURVEYING, INC.  
 17750 N. HIGHWAY 79  
 BLACK HAWK, SD 57716  
 PH. (605) 716-7988

LOT A & LOT B OF 14 LESS N. 80'  
 OF E. 255' OF LOT B, PLATTED,  
 SEC 4, T1N, R7E, BHM, RAPID CITY  
 PENNINGTON COUNTY, SOUTH DAKOTA

LAYOUT AND LANDSCAPE PLAN  
 EVERGREEN TOWNHOMES & APARTMENTS  
 BOBBY AND GENAE SUNDSY



BRITTON ENGINEERING & LAND SURVEYING, INC.  
 11750 N. HIGHWAY 79  
 BLACK HAWK, SD 57718  
 PH. (605) 718-7988

LOT A & LOT B OF 14 LESS N 80'  
 OF E 255' OF LOT B, PLATTED  
 SEC. 4, T.1N., R.7E, BHM, RAPID CITY  
 PENNINGTON COUNTY, SOUTH DAKOTA

ROAD, WATER, AND SEWER PLAN & PROFILE  
 STA 0+00 TO STA 4+50  
 EVERGREEN TOWNHOMES & APARTMENTS  
 BOBBY & GEMME SUNDBY

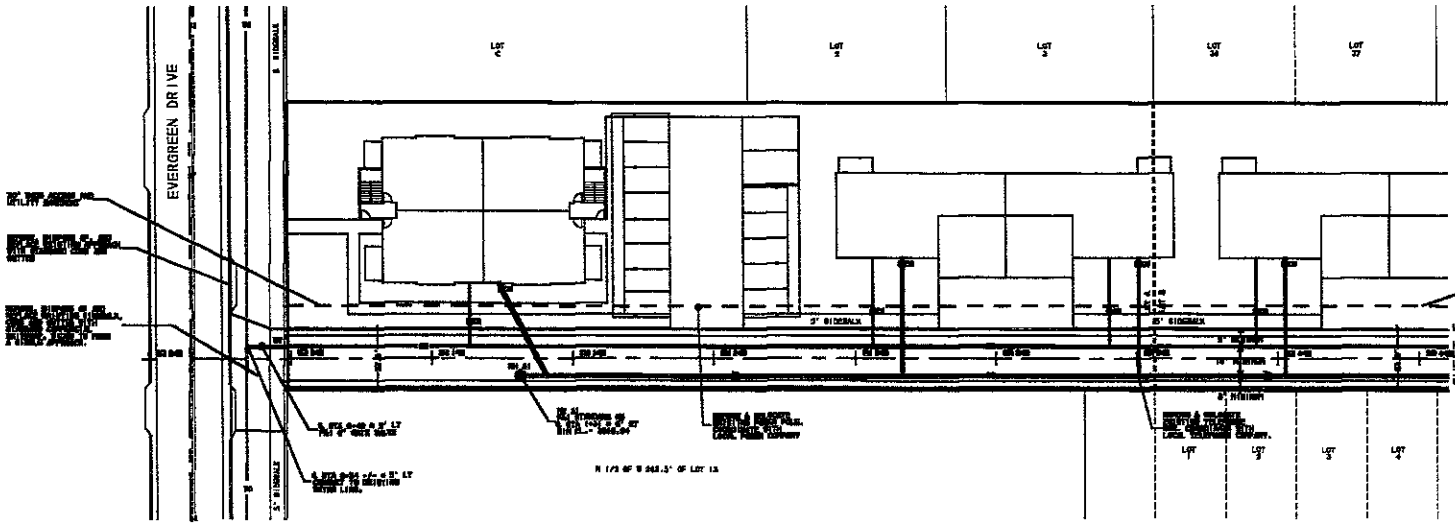

- NOTES:**
- REMOVE AND DISPOSE OF EXISTING BUILDINGS, TREES, FENCING, AND OTHER MATERIAL.
  - ANY UTILITY RELOCATED SHALL BE COORDINATED WITH LOCAL UTILITY COMPANY.
  - UNDRAINS SHALL PARALLEL NEW CURB AND GUTTER ON NORTH SIDE AS SHOWN IN DETAILS.
  - CONTRACTOR SHALL FIELD VERIFY THE DEPTH AND LOCATION OF EXISTING WATER LINE AND SHALL CONTACT THE ENGINEER WITH ANY DISCREPANCY.
  - CONTRACTOR TO COORDINATE CONNECTION TO RAPID CITY WATERLINE WITH CITY OF RAPID CITY PUBLIC WORKS DEPARTMENT.

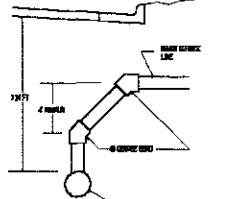
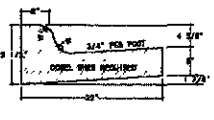
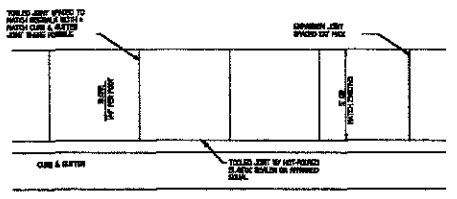
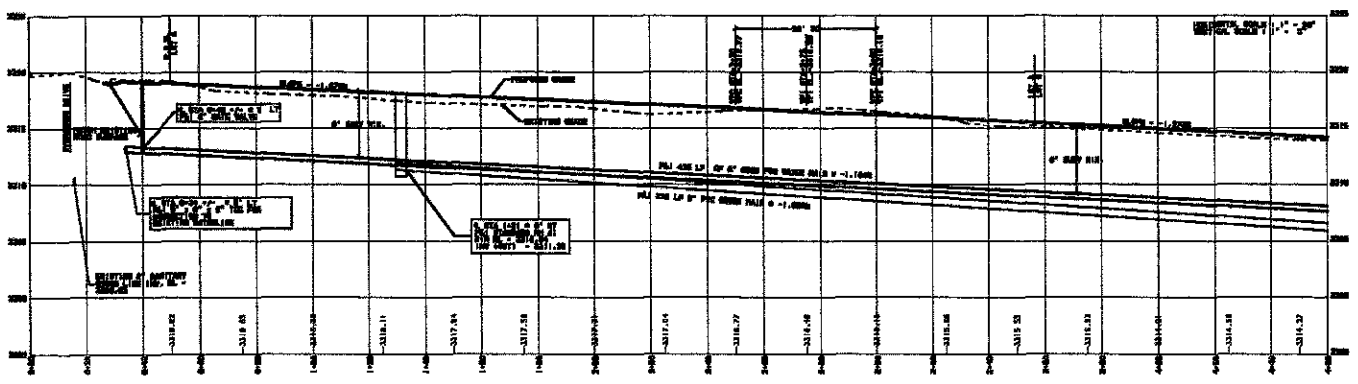

ALL SIDEWALKS SHALL BE A MINIMUM OF 4" THICK CONCRETE WITH A MINIMUM OF 2" OF COMPACTED CARBON MATERIAL PLACED UNDER THE SIDEWALK.

**CURB AND GUTTER**

**STANDARD CURB & GUTTER SECTION**

**STANDARD SANITARY SEWER SERVICE CONNECTION**

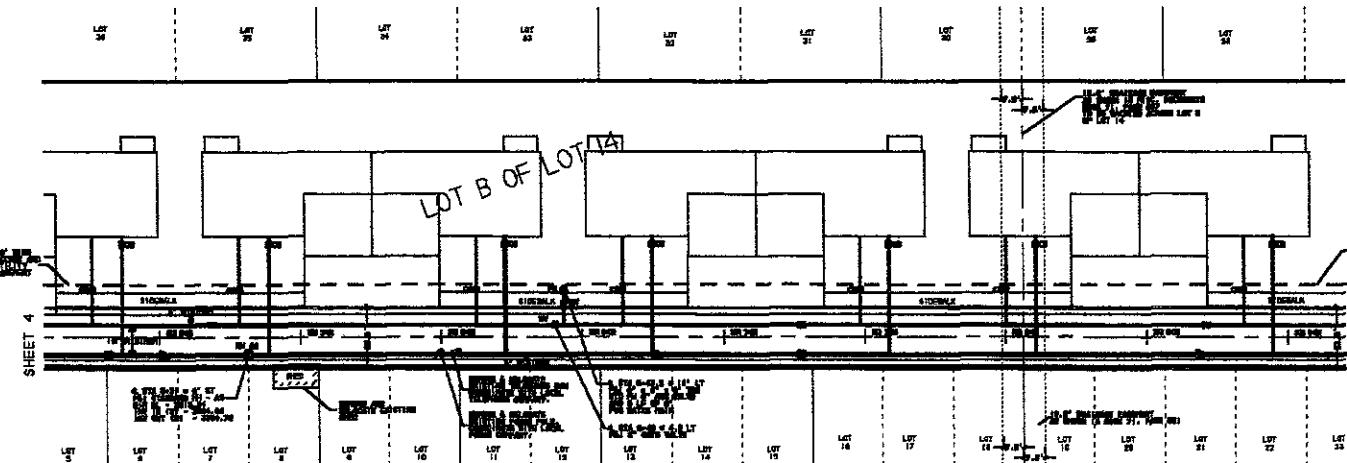

SHEET 4

SHEET 5



**NOTES:**  
 REMOVE AND DISPOSE OF EXISTING BUILDINGS, TREES, FENCINGS, AND OTHER UTILITIES.  
 ANY UTILITY RELOCATED SHALL BE COORDINATED WITH LOCAL UTILITY COMPANY.  
 UNDERLAIN SHALL PARALLEL NEW CURB AND CUTTER ON NORTH SIDE AS SHOWN IN DETAILS.

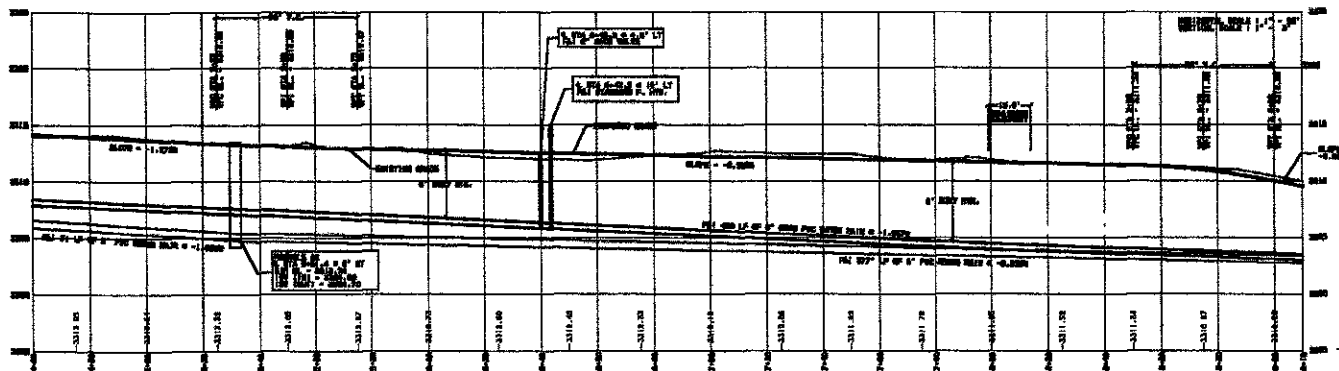

RECEIVED

MAR 24 2005

Rapid City Growth Management Department

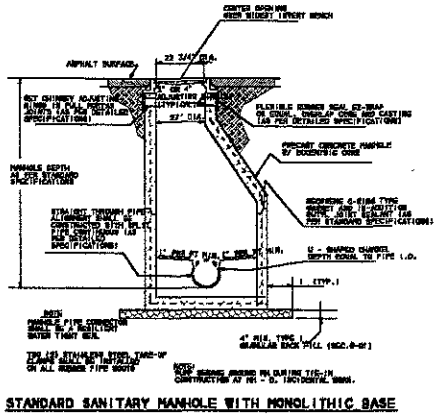
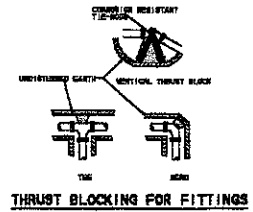
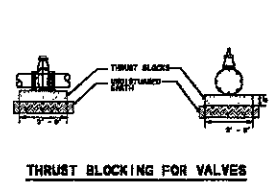
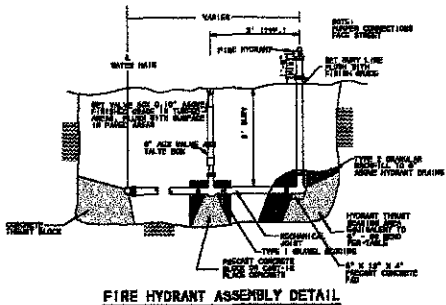

BRITTON ENGINEERING & LAND SURVEYING, INC.  
 1750 N. HIGHWAY 79  
 BLACK HAWK, SD 57718  
 PH. (605) 716-7988

LOT A & LOT B OF 14 LESS N. 80' OF E. 255' OF LOT B, PLATD. SEC 4, T1N, R7E, BHM, RAPID CITY PENNINGTON COUNTY, SOUTH DAKOTA

ROAD, WATER AND SEWER PLAN AND PROFILES  
 STA 4+60 TO STA 9+10  
 EVERGREEN TOWNHOMES & APARTMENTS  
 BOBBY AND GENNE SUNDBY

5  
 9



WEST SIDE

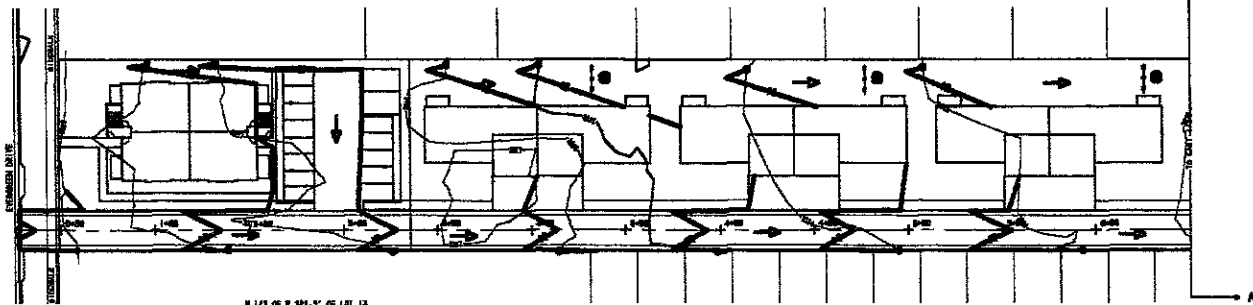

N 1/2 OF R 282.5' OF LOT 13

WEST SIDE

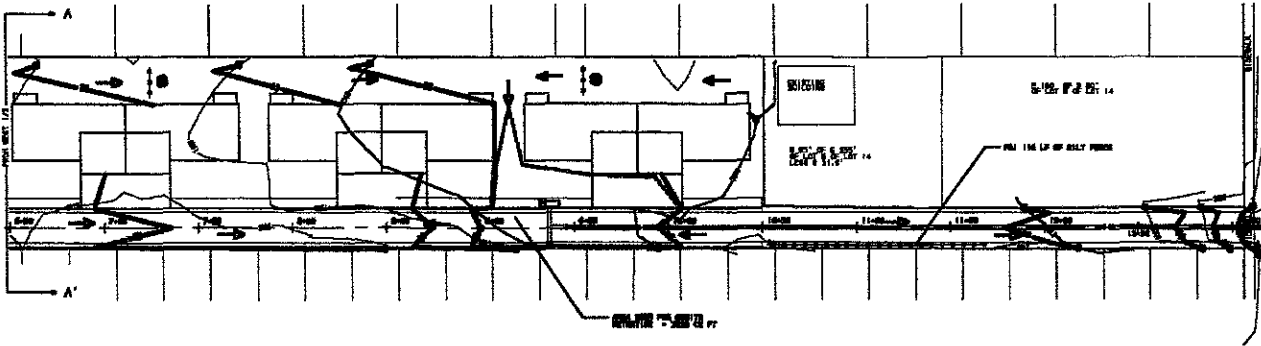

REQUIRE 15'-0" MIN. CLEARANCE

EXISTING CONDITIONS	
AS	2.0' 0"
MS	2.0' 0"
MS	2.0' 0"
+PLAN RELEASED SEPARATE	



SCALE: 1" = 20'  
JANUARY 28, 2005

IMPROVED CONDITIONS	
AS	2.0' 0"
MS	2.0' 0"
MS	2.0' 0"
+PLAN RELEASED SEPARATE	

IMPROVED CONDITIONS	
AS	2.0' 0"
MS	2.0' 0"
MS	2.0' 0"
+PLAN RELEASED SEPARATE	

IMPROVED CONDITIONS	
AS	2.0' 0"
MS	2.0' 0"
MS	2.0' 0"
+PLAN RELEASED SEPARATE	

NOTES:  
1. ALL DIMENSIONS ARE IN FEET AND INCHES.  
2. ALL DIMENSIONS ARE TO FACE UNLESS OTHERWISE NOTED.  
3. ALL DIMENSIONS ARE TO FACE UNLESS OTHERWISE NOTED.  
4. ALL DIMENSIONS ARE TO FACE UNLESS OTHERWISE NOTED.  
5. ALL DIMENSIONS ARE TO FACE UNLESS OTHERWISE NOTED.  
6. ALL DIMENSIONS ARE TO FACE UNLESS OTHERWISE NOTED.

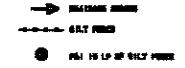

SCALE: 1" = 20'  
JANUARY 28, 2005

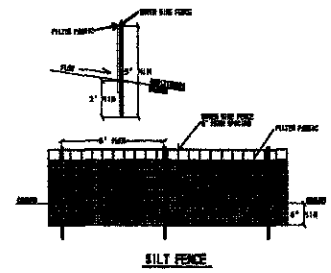
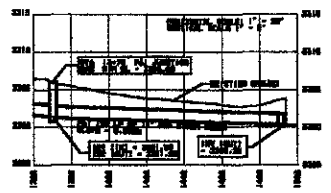
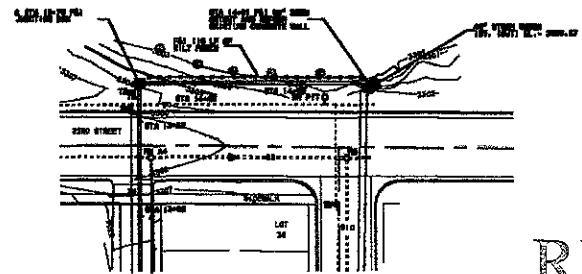

RECEIVED

MAR 24 2005

Rapid City Growth  
Management Department

BRITTON ENGINEERING & LAND SURVEYING, INC.  
11750 N. HIGHWAY 79  
BLACK HAWK, SD 57718  
PH. 605.716.7988

GRADING AND DRAINAGE PLAN.  
EROSION CONTROL PLAN  
EVERGREEN TOWNHOUSES & APARTMENTS  
BOBBY AND GENAE SUNDBY

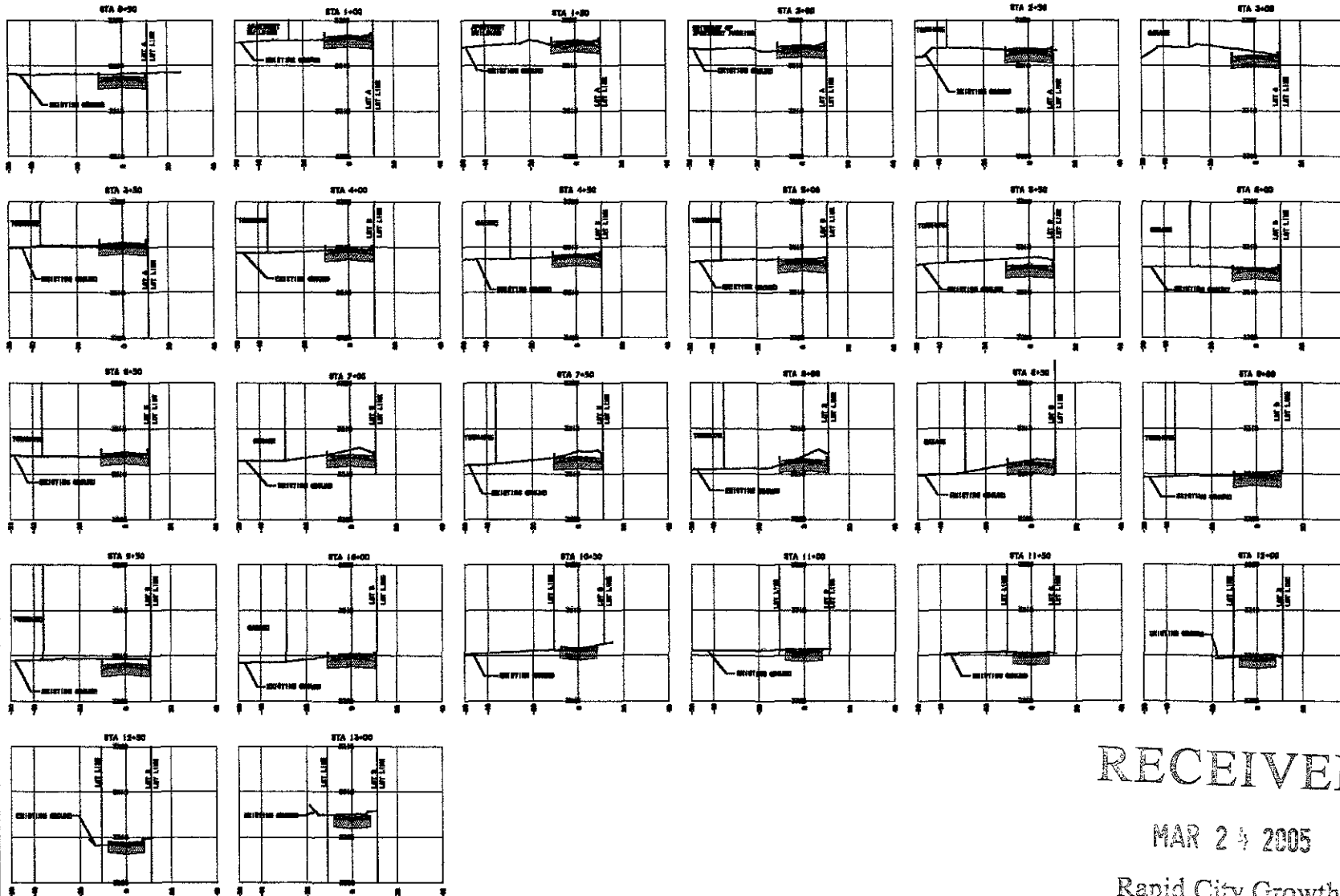

RECEIVED

MAR 24 2005

Rapid City Growth  
Management Department

BRITTON ENGINEERING & LAND SURVEYING, INC  
11750 N. HIGHWAY 79  
BLACK HAWK, SD 57718-9133  
PH. (605) 716-7988

LOT 4, LOT B OF 14 LESS N 80'  
OF E 255' OF LOT B PLATTED  
SECTION 4, T1N, R7E, B1M, RAPID CITY  
PENNINGTON COUNTY, SOUTH DAKOTA

ROAD CROSS SECTIONS  
EVERGREEN TOWNHOMES AND APARTMENTS  
BOBBY AND GENAE SUNDRY

8  
9



# Rapid City Growth Management Department

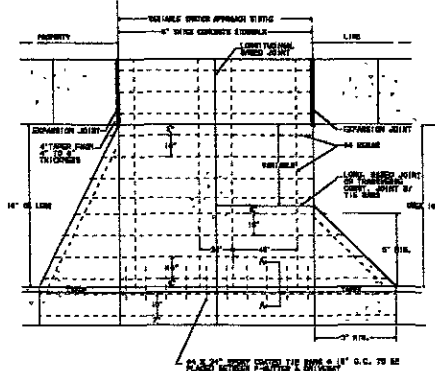

REINFORCED DRIVEWAY APPROACH SHALL BE PLACED AT ALL ALLEY DRIVEWAYS & ALL DRIVEWAYS TO REAR YARDS, CONNECTING TO MAIN DRIVEWAY. APPROACH SHALL BE 4" THICK CONCRETE & REIN. TRAFFIC LINE STRENGTH 5000 PSI.

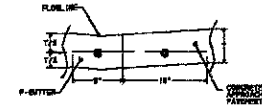

REINFORCED DRIVEWAY APPROACH

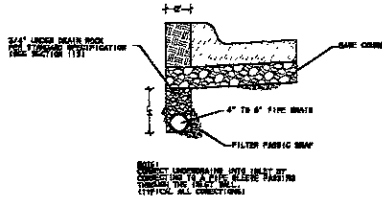

UNDER DRAIN - NEW CURB & GUTTER

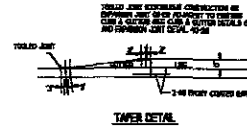

STANDARD DRIVEWAY APPROACH PAVEMENT

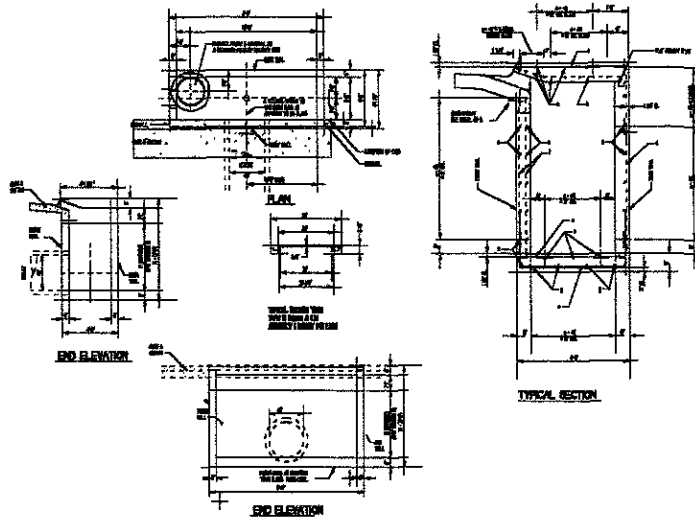
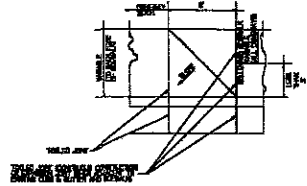
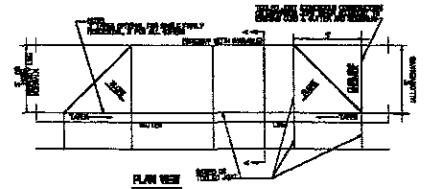

TYPE E - DROP INLET DETAIL

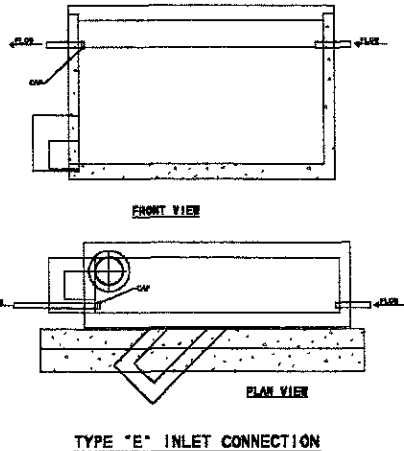

TYPE "E" INLET CONNECTION

BRITTON ENGINEERING & LAND SURVEYING, INC  
11750 N. HIGHWAY 70  
BLACK HAWK, SD 57716-9133  
PH. (605) 716-7988

LOT A & LOT B OF 14 LESS N 80'  
OF E 255' OF LOT B, PLATTED  
SECTION 4, T.1N. 87E. B.M. RAPID CITY  
PENNINGTON COUNTY, SOUTH DAKOTA

DETAILS  
EVERGREEN TOWNHOMES AND APARTMENTS  
BOBBY AND GENAE SUNDBY