

1000017

DEVELOPMENT SERVICES CENTER

Growth Management Department

City of Rapid City

300 Sixth Street, Rapid City, SD 57701-2724

Phone: (605) 394-4120

Fax: (605) 394-6636

Web: www.rcgov.com

**HISTORIC PRESERVATION
11.1 REVIEW**

PROJECT NAME: FIRST PRESBYTERIAN CHURCH

PROJECT ADDRESS: 710 KANSAS CITY STREET
RAPID CITY, SD 57701

DESCRIPTION OF REQUEST:
REPLACE WINDOWS IN VARIOUS LOCATIONS FOR ENERGY EFFICIENCY. WINDOWS REPLICATE EXISTING WINDOWS

YEAR CONSTRUCTED:

HISTORIC DISTRICT:

West Boulevard Historic District Environs of West Boulevard Historic District

Downtown Historic District Environs of Downtown Historic District

Individually Listed Property Environs of an Individually Listed Property

STATUS:

Contributing Non-Contributing

TYPE:

Commercial Residential

OWNER OF RECORD

Name: <u>SESSION</u>	Phone #: <u>605-343-6171</u>	Fax #: <u>605-343-4364</u>
Mailing Address: <u>710 KANSAS CITY STREET</u>	City, State, Zip: <u>RAPID CITY, SD 57701</u>	
Owner's Signature: <u>X Robert A. Martin Trustee</u>	Date: <u>9-13-20</u>	

APPLICANT (If different from owner of record)

Name:	Phone #:	Fax #:
Mailing Address:	City, State, Zip	
Applicant's Signature:	Date:	

FIRST PRESBYTERIAN CHURCH WINDOW REPLACEMENT

WINDOW #	LOCATION	WIDTH	HEIGHT
1	Room 204 - Café	81.5	48.25
2	Room 204 - Café	60	48.25
3	Room 204 - Café	81.5	48.25
4	Room 206 - Kitchen	60	36.25
5	Art Studio	60	48.25
6	Art Studio	60	48.25
7	Room 210- Studio	40	48.25
8	Chior Room	19.75	48.25
9	Chior Room	19.75	48.25
10	Chior Room	81.5	48.25
11	Chior Room	81.5	48.25
12	Stairwell	20.5	142.5
13	Room 207 Studio 2	40	48.25
14	Room 207	60	48.25
15	Room 207	60	48.25
16	Room 207	60	48.25
17		20	48.25
18	Room 106	60	60
19	Room 106	60	60
20	Room 106	60	60
21	Room 108	60	60
22	Women's	19.5	60
23	Men's	19.5	60
24	Room 2	81.5	48.25
25	Room 2	81.5	48.25
26	Room 4	81.5	48.25
27	Room 6	81.5	48.25
28	Room 6	81.5	48.25
29	Room 6	60	48.25
30	Room 8	60	48.25
31	Room 10	60	48.25
32	Room 10	60	48.25
33	Women's	19.5	48.25
34	Men's	19.5	48.25
35	Mechanical Room	40	48.25
36	Mechanical Room	60	48.25
37	Mechanical Room	59	48.25
38	Pump Room	19.25	35.75
39	Bathroom	19.5	48.25
40	Lounge	60	60
41	Lounge	40	60
42	Lounge	60	60
43	Lounge	40	60
44	Stairwell	19.5	48.25
45	Across from Lounge	19.5	60
46	Sanctuary	19.5	48.25
47	Sanctuary	19.5	48.25
48	Teacher Resource (LL)	57.5	59
49	Library (LL)	56.5	59.5
50	Library (LL)	56.5	59.5
51	Room 5	56.5	59.5
52	Room 3	80	60
53	Room 1	80	59.5
54	Wharf West	59.75	36
55	Wharf West	59.75	36
56	Wharf South	80	36
57	Wharf East	59.75	36
58	Wharf East	59.75	36
59	Balcony	20	48
60	Balcony	20	48
61	Balcony	20	48

North Elevation Installation 1 of 3 14 ea / 25 ea Total

Window 1
Room 204

Window 2
Room 204

Window 4
Room 206

Window 5
Art Studio

Window 6
Art Studio

Window 18
Room 108

Window 19
Room 108

Window 20
Room 106

Window 21
Room 108

Window 28
Room 6

Window 29
Room 6

Window 30
Room 8

Window 31
Room 10

Window 32
Room 10



North Elevation Installation 2 of 3 - 6 ea / 25 ea Total



Window 7
Studio 1
Room 210

Window 17

Window 22
Women's RR

Window 28
Men's RR

Window 33
Women's RR

Window 34
Men's RR

North Elevation 3 of 3 5 ea 2 35 ea Total



Window 43
Lounge



Window 42
Lounge



Window 41
Lounge



Window 35
Mechanical
Room



Window 36
Mechanical Room



East Elevation Installation - 12 ea Window Units



Window 12
Stairwell

Window 11
Chior Room

Window 10
Chior Room

Window 9
Chior Room

Window 8
Chior Room

Window 3
Room 204

FIRST PRESBYTERIAN CHURCH

Window 57
Wharf Room
East

Window 58
Wharf Room
East

Window 25
Room 2

Window 24
Room 2

Window 26
Room 4

Window 27
Room 6



West Elevation Installation — Add South Wharf Unit

Window 56
Wharf Room South

West Elevation Installation Add South Sanctuary Units

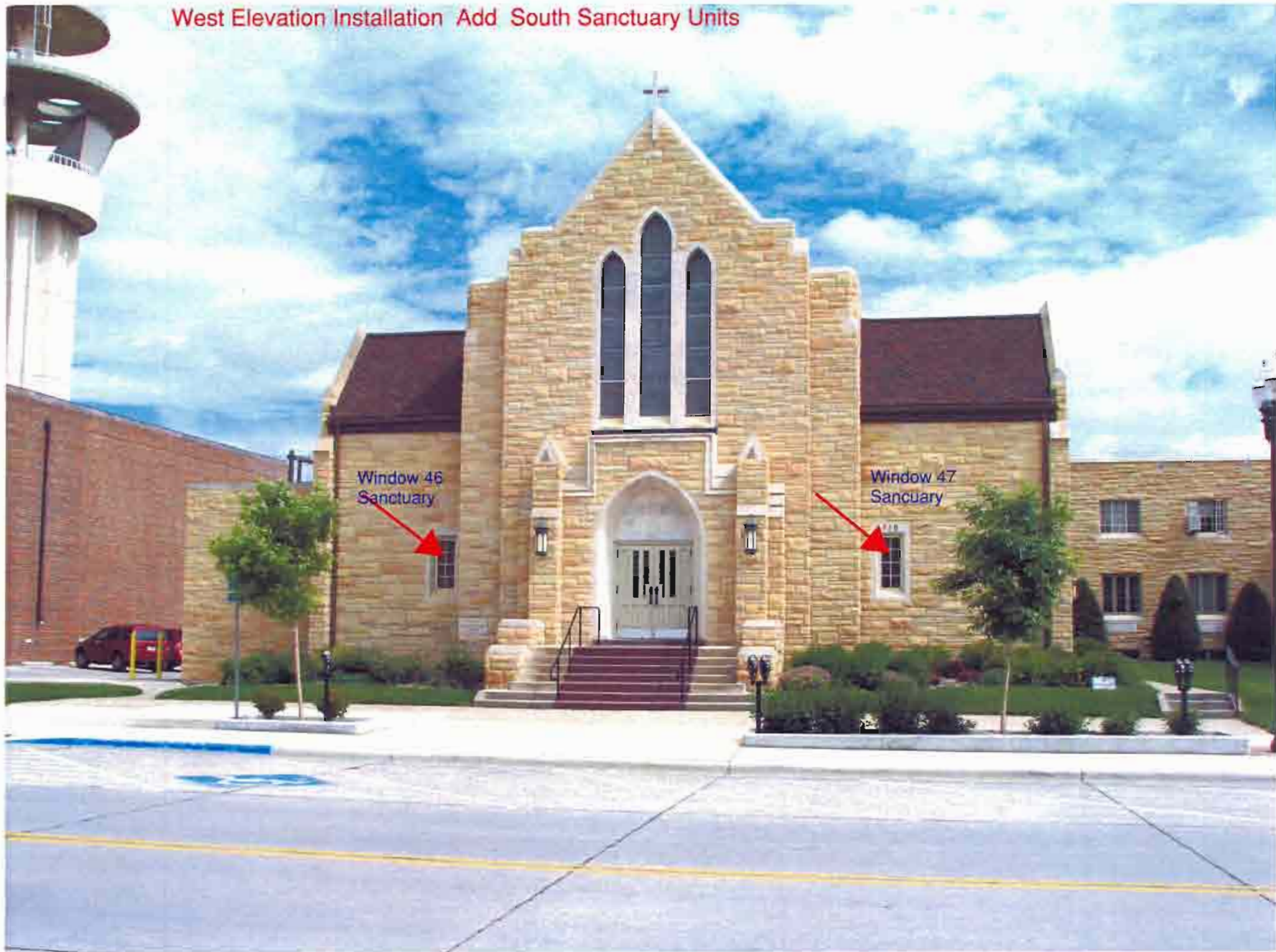

Window 46
Sanctuary

Window 47
Sancuary

West Elevation Installation 2 of 4



Window 45
Across From
Lounge

Window 58
Balcony

Window 60
Balcony

Window 59
Balcony

West Elevation Installation 1 of 4



Window 40
Lounge

Window 39
Bathroom

Window 44
Stairwell

Window 37
Mechanical
Room

Window 38
Pump Room

South Courtyard Installation 1 of 2



South Courtyard Installation 2 of 2



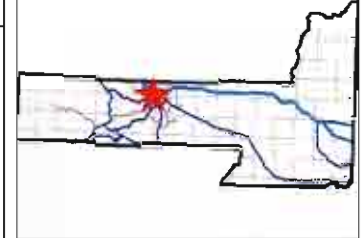

Legend

- Historic Structures**
 - CONTRIBUTING BUILDING
 - CONTRIBUTING GARAGE
 - CONTRIBUTING SHED
 - NON-CONTRIBUTING BUILDING
 - NON-CONTRIBUTING GARAGE
 - NON-CONTRIBUTING SHED
 - NON-CONTRIBUTING STATUE
- Roads**
 - Not classified
 - Interstate
 - US Highway
 - SD Highway
 - County Highway
 - Main Road
 - Minor Arterial
 - Collector
 - Ramp
 - Paved Road
 - Unpaved Road
 - Unimproved Road
 - Trail
 - other
 - Not yet coded
- ▲ Historic District Boundary
- Historic Properties
- Township/Section lines
- SECTION
- TOWNSHIP
- Parcel Boundary
- Lot Lines
- COUNTY
- LOT LINE
- PARCEL LINE



Scale: 1:1,401

0 140 280 420 ft.

Map center: 44° 4' 46.7" N, 103° 13' 47.9" W

DISCLAIMER: This map is provided 'as is' without warranty of any representation of accuracy, timeliness, or completeness. The burden for determining accuracy, completeness, timeliness, merchantability, and fitness for or the appropriateness for use rests solely on the user. Rapid City and Pennington County make no warranties, express or implied, as to the use of the map. There are no implied warranties of merchantability or fitness for a particular purpose. The user acknowledges and accepts the limitations of the map, including the fact that the data used to create the map is dynamic and is in a constant state of maintenance, correction, and update. This document does not represent a legal survey of the land. There are no restrictions on the distribution of printed Rapid City/Pennington County maps, other than the City of Rapid City copyright/credit notice must be legible on the print. The user agrees to recognize and honor in perpetuity the copyrights and other proprietary claims for the map(s) established or produced by the City of Rapid City or the vendors furnishing said items to the City of Rapid City.

Notes: Environs - downtown and individual, non-contributing

First Presbyterian Church window replacement.

- The current windows in the church are steel casements with authentic divided light.
- The proposed all Ultrex (fiberglass) windows will be built to match the size, light pattern and color of the original windows.
- Several of the units were replaced in fall of 2009 with Pella Impervia windows which were approved by the Rapid City Historic Preservation Commission.
- What's being proposed here today will match the Impervia with the same design, light pattern exterior color and method of installation. The exterior will have approximately a 1 ¼" frame expander around the exterior.
- See specifications, drawings and samples



ALL ULTREX CASEMENT/AWNING

UNIT FEATURES

FRAME:

The frame is made of Ultrex[®], an advanced fiber reinforced material that is exceptionally resistant to thermal conductance. Composite frame thickness is 1 1/2" (38 mm). Total frame depth is 3 3/32" (79 mm). Ultrex is 0.070" - 0.077" (2 mm) thick. Exterior Colors: Stone White, Pebble Gray, Bronze, Evergreen, Cashmere or Ebony. Interior Color is Stone White.

SASH:

The frame is made of Ultrex, an advanced fiber reinforced material that is exceptionally resistant to thermal conductance. Composite sash thickness is 15/16" (24 mm). Ultrex is 0.070" - 0.077" (2 mm) thick. Exterior Colors: Stone White, Pebble Gray, Bronze, Evergreen, Cashmere or Ebony. Interior Color is Stone White. Sashes can be replaced but not reglazed.

JAMB EXTENSION:

Standard jamb depth is 2" (51 mm). 4 9/16" (116 mm) and 6 9/16" (167 mm) maintenance free jamb extension available.

HARDWARE:

Standard Casement hardware includes top and bottom hinges. The hinge track is stainless steel with an injected molded hinge shoe. The hinge arm is coated with E-Gard. A snubber on the jamb and stile, certain heights have 0, 1 or 2 sets, interlock the sash to the frame on the hinge side. The locking hardware consists of a multi-point locking mechanism that is actuated from a single point of operation. The roto operator is Zinc die cast with an E-Gard coating. The hardware finish options are: Stone White, Almond Frost, Brass, Satin Nickel and Oil Rubbed Bronze. The Awning hardware consists of 2 hinges, one on each side, a single point lock on each jamb/stile, and a single roto mechanism.

INSTALLATION:

Factory applied folding nailing fin. Optional installation brackets for masonry applications are available. Factory supplied field mull kits are available for standard assemblies.

GLAZING:

All units manufactured with 3/4" (19 mm) insulating glass Low E II with Argon [LoE³ 366⁺]. All glass is of a select quality complying with Federal Specifications DD-F-451D, ASTM C 1036-85. Insulating glass is manufactured and tested to pass level CBA, ASTM E 774 and is IGCC certified. The glazing seal is a silicone bedding on the exterior surface, and a vinyl seal on the interior surface.

WEATHER STRIPPING:

The primary weather strip is a black extruded PVC foam filled bulb that attaches to all four sides of the frame. The secondary weather-strip is a black extruded PVC hollow that is attached to the sash.

INSECT SCREEN:

Charcoal color fiberglass screen cloth, 18 x 16 screen mesh. Aluminum frame finish is Stone White. Features a bottom rail lift and top rail mounted springs that allow it to be removed from the interior of the unit.

GRILLES-BETWEEN-THE-GLASS:

11/16" (17mm) contoured aluminum bar placed between two panes of glass. Patterns: Standard rectangular pattern or optional 9 lite Prairie cut. Exterior color will match exterior of sash color. The interior finish is always Stone White. GBGs are not available on Impact units.

PERFORMANCE RATING:

Complies with AAMA/WDMA/CSA 101/I.S.2/A440-05, ANSI/AAMA/NWDA 101/I.S.2-97, ANSI/101/I.S.2/NAFS-02

ACCESSORIES:

Field applied j-channel or a 3" frame expander. Interior: Factory applied sheet rock return for 1/2" or 5/8" drywall or a 3/4" receiver. General: Mull kits are available for field assembly. Kits include instructions, mull covers, mull plugs and brackets.

*STANDARD SIZE NOMINAL CALL NUMBERS ARE BASED ON ROUGH OPENING

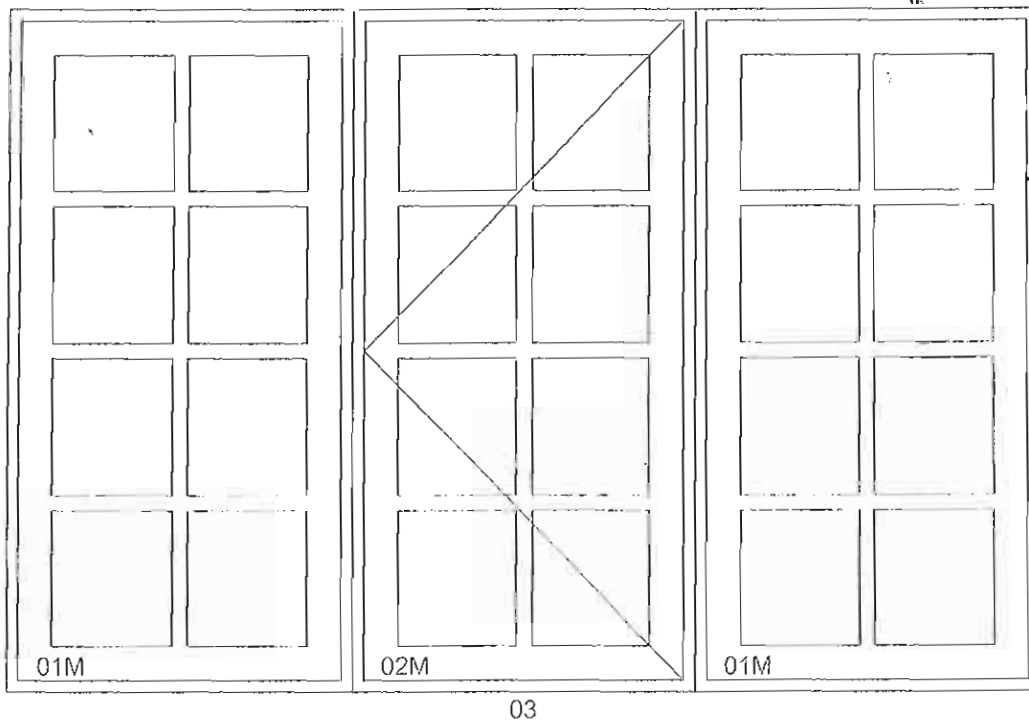

ALL NEW UNITS TO MATCH
SIZE AND LIGHT CUT OF EXISTING.

SECTION DETAILS SCALE: 3" = 1'0"

CASEMENT

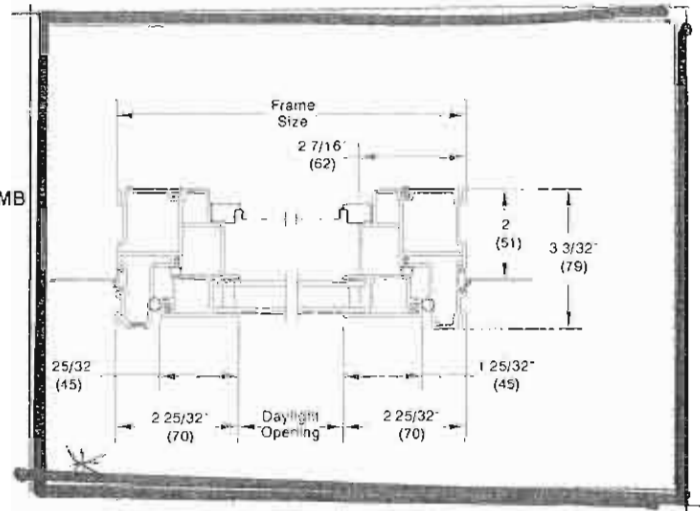
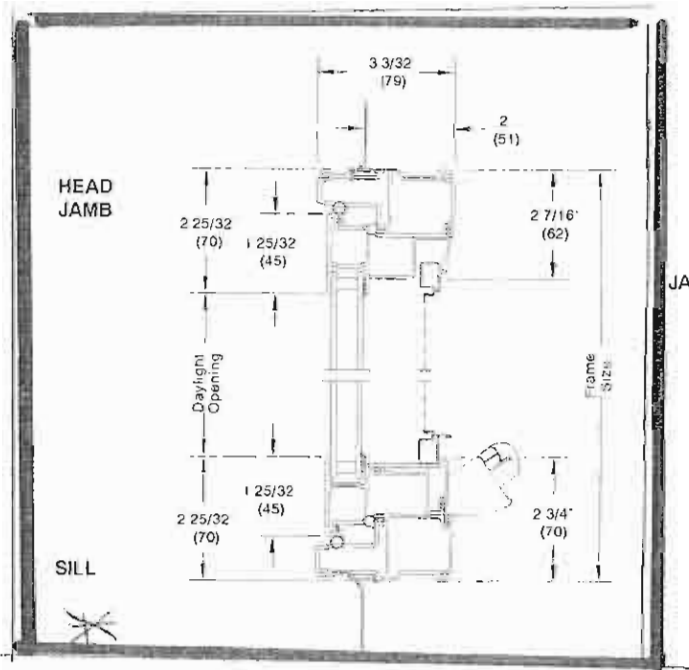

NOTE: Units also available with 4 9/16" jamb. Same jamb extension profile as 6 9/16" jamb extension shown.

CASEMENT - 6 9/16"

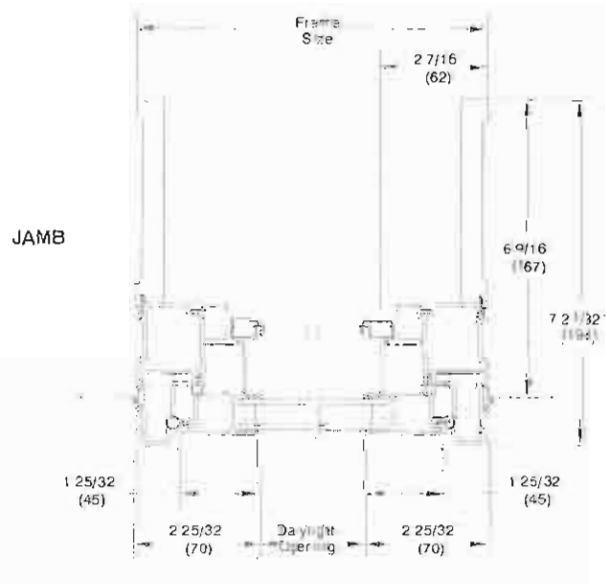
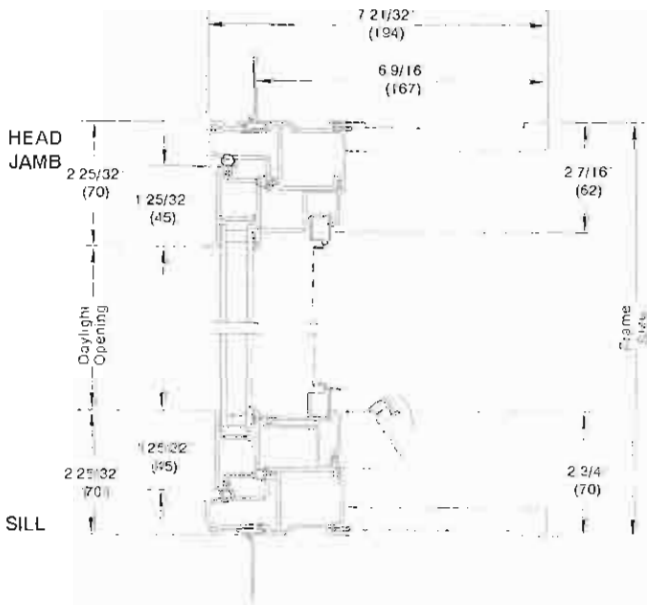

MULLIONS

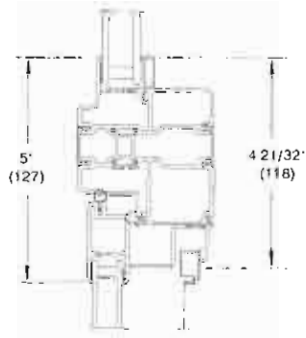

HORIZONTAL
 IFDGP TO IFCA/IFAWN/IFSWT/IFSWP

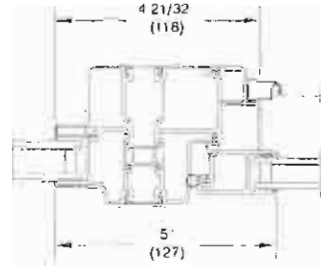

VERTICAL
 IFDGP TO IFCA/IFAWN/IFSWT/IFSWP

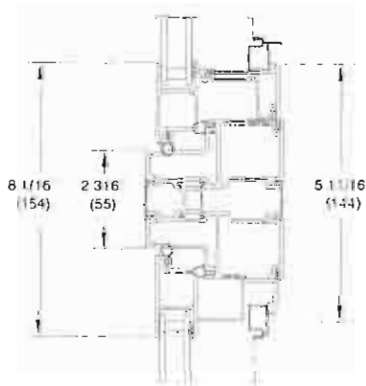

HORIZONTAL
 IFCA/IFAWN/IFSWT/IFSWP TO
 IFCA/IFAWN/IFSWT/IFSWP

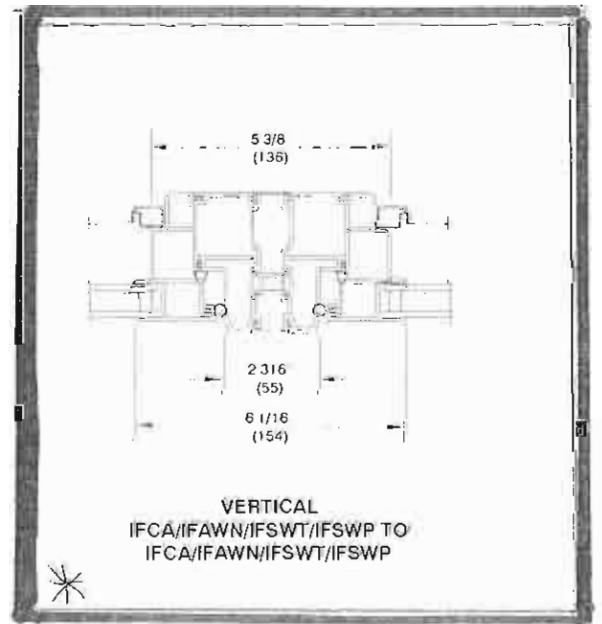

VERTICAL
 IFCA/IFAWN/IFSWT/IFSWP TO
 IFCA/IFAWN/IFSWT/IFSWP

MULLION