



AIA[®]

Document G701[™] – 2001

Change Order

PROJECT (<i>Name and address</i>): Rapid City Utility Maintenance Facility Rapid City, South Dakota	CHANGE ORDER NUMBER: 002 DATE: February 19, 2015	OWNER: <input checked="" type="checkbox"/> ARCHITECT: <input checked="" type="checkbox"/> CONTRACTOR: <input checked="" type="checkbox"/> FIELD: <input type="checkbox"/> OTHER: <input type="checkbox"/>
TO CONTRACTOR (<i>Name and address</i>): SECO Construction, Inc. P.O. Box 2921 Rapid City, SD	ARCHITECT'S PROJECT NUMBER: 13373 CONTRACT DATE: September 17, 2014 CONTRACT FOR: General Construction	

THE CONTRACT IS CHANGED AS FOLLOWS:

(Include, where applicable, any undisputed amount attributable to previously executed Construction Change Directives)

- RFP #006 - Add automatic shut down on HVLV fans / sprinkler flow - Add: \$1,553.00
- RFP #007 - Increase height of mezzanine floor - Add: \$4,574.00
- RFP #008 - Omit clean rock at all overhead doors - Deduct: (\$1,690.00)
- RFP #009 - Omit dampproofing at foundation walls - Deduct: (\$2,686.00)
- RFP #010 - Modify electrical chain hoist / trolley - Deduct: (\$1,637.00)
- RFP #011 - Hardware change per owner request - Add: \$5,924.00
- Total Add: \$6,038.00

The original Contract Sum was	\$ 4,288,000.00
The net change by previously authorized Change Orders	\$ 210411.20
The Contract Sum prior to this Change Order was	\$ 4,498,411.20
The Contract Sum will be increased by this Change Order in the amount of	\$ 6,038.00
The new Contract Sum including this Change Order will be	\$ 4,504,449.20

The Contract Time will be increased by Zero (0) days.

The date of Substantial Completion as of the date of this Change Order therefore is September 1, 2015

NOTE: This Change Order does not include changes in the Contract Sum, Contract Time or Guaranteed Maximum Price which have been authorized by Construction Change Directive until the cost and time have been agreed upon by both the Owner and Contractor, in which case a Change Order is executed to supersede the Construction Change Directive.

NOT VALID UNTIL SIGNED BY THE ARCHITECT, CONTRACTOR AND OWNER.

Upper Deck Architects, Inc. ARCHITECT (<i>Firm name</i>)	SECO Construction, Inc. CONTRACTOR (<i>Firm name</i>)	City of Rapid City OWNER (<i>Firm name</i>)
50 Minnesota Street, Suite 1, Rapid City, SD 57701 ADDRESS	P.O. Box 2921, Rapid City, SD ADDRESS	300 6th Street, Rapid City, SD 57701 ADDRESS
 BY (<i>Signature</i>)	 BY (<i>Signature</i>)	BY (<i>Signature</i>)
Jerry D. Eisenbraun (Typed name)	NEAL SCHLOTZMAN (Typed name)	(Typed name)
2/19/15 DATE	2-24-15 DATE	DATE

RFP #006



UPPER DECK
ARCHITECTS, INC.

50 MINNESOTA ST. - SUITE 1
RAPID CITY, SD 57701
PH: 605 721-0237
FAX: 605 721-0240

Jerry D. Eisenbraun

From: Johnson Rod <Rod.Johnson@rcgov.org>
Sent: Tuesday, December 23, 2014 8:25 AM
To: Jerry D. Eisenbraun
Cc: Neal Schlottman
Subject: RE: RCUMF RFP Recommendations

Proposal #6 and #8 are acceptable. Please include in the next change order.

RJ

From: Jerry D. Eisenbraun [<mailto:jerrye@upperdeckarchitects.com>]
Sent: Monday, December 22, 2014 4:46 PM
To: Johnson Rod
Subject: RCUMF RFP Recommendations

Rod,

Attached are our recommendations for RFPs #6 and #8. Please note both of these have a response deadline before additional days need to be considered.

Jerry D. Eisenbraun
Project Manager

UPPER DECK ARCHITECTS, INC.

50 Minnesota Street - Suite 1
Rapid City, SD 57701

SPH (605) 721-0237 **BFX** (605) 721-0240

Visit us at: www.upperdeckarchitects.com

RFP #006 RECOMMENDATION



UPPER DECK
ARCHITECTS, INC.

50 MINNESOTA ST. - SUITE 1
RAPID CITY, SD 57701
PH: 605 721-0237
FAX: 605 721-0240

To: Rod Johnson

Project: Rapid City Utility Maintenance Facility

Project #: 13373

From: Jerry D. Eisenbraun

Date: 12/22/2014

Content: RFP #006 Recommendation

Rod:

Attached is the pricing information from SECO Construction, Inc. for Proposal Request No. 6 – Fire Alarm Fan Shutdown. This change is required due to new code / city requirements for High Volume Low Speed (HVLS) fans per email received from the Rapid City Fire Department on 11/26/14. We and our consultants have reviewed and find to be commensurate with the work required.

We recommend acceptance of RFP #006 for a cost **add of \$1,553.00**. If this is acceptable, please forward to us your decision regarding this item, and we will ensure this is incorporated into the next change order. Please note deadline for approval before additional time needs to be considered.

Sincerely,
Jerry D. Eisenbraun



P.O. BOX 2921 RAPID CITY, SD 57709 (605)348-7085 FAX (605)348-8287

December 22, 2014

VIA EMAIL

Mr. Jerry Eisenbraun
Upper Deck Architects, Inc.
50 Minnesota Street, Suite 1
Rapid City, SD 57701

Subject: Proposal for RFP #6, Rapid City Utility Maintenance Facility, Rapid City, SD

Dear Jerry,

We propose to provide the fire alarm fan shutdown as outlined in Request for Proposal #6 dated December 11, 2014 for an additional cost of \$1,553.00. The estimate cost summary sheet for this work and associated documentation are enclosed for your review.

The work outlined in this proposal request will not require a contract time change if we receive written notice to proceed on this proposal no later than January 2, 2015.

Sincerely,
SECO Construction, Inc.

A handwritten signature in black ink, appearing to read "Neal A. Schlottman".

Neal A. Schlottman
President

enclosures



SECO Construction, Inc.
 REQUEST FOR PROPOSAL COST SUMMARY
 Rapid City Utility Maintenance Facility

Proposal Request No. 6

<u>Subcontractors</u>	<u>Work Description</u>	<u>Amount</u>
Al Sutton Electric	Electrical Revisions for Fan Shutdown	1,301.77
SUBCONTRACTOR SUBTOTAL		1,301.77
<u>GC Labor</u>		
Superintendent		60.00
LABOR SUBTOTAL		60.00
<u>GC Materials</u>		
MATERIAL SUBTOTAL		-
Sales Tax	6.00%	-
LABOR SUBTOTAL		60.00
GC Overhead	8%	4.80
SUBCONTRACTOR TOTAL		1,301.77
SUBTOTAL		1,366.57
GC Profit	10%	136.66
SUBTOTAL		1,503.23
Bond/Insurance	1.25%	18.79
State Excise Tax	2.041%	31.06
TOTAL		1,553.08
TOTAL THIS PROPOSAL		\$ 1,553

AL SUTTON ELECTRIC, INC.

PO Box 3538
Rapid City, SD 57709

Office (605) 341-5300
Fax (605) 342-1686

December 22, 2014

Seco Construction

RE: City of Rapid City, Utility Maintenance Facility RFP 006

**Price for RFP 6 based on attached documentation
\$1301.77**

Thanks,

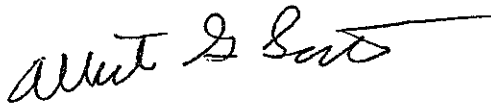

**Albert G. Sutton
President
Al Sutton Electric**

BID SUMMARY REPORT

Name: Utility Maintenance Facility

Estimator: Admin

Job #: 60

Job Name: Utility Maintenance Facility
Contractor:
Estimator: Admin
Notes:
Bid Date:

Included Summary Description	Extended	%	Adjusted Material	Extended	%	Adjusted Labor
<input type="checkbox"/> RFP 6	\$87.72	100.00	\$87.72	8.58	100.00	8.58

Top Sheet			
Raw Cost	\$1,162.48	Sales Per Month	\$0.00
Tax	\$20.95	Return Per Month	\$0.00
Raw Cost With Tax	\$1,183.43	Price Per Sq Foot	\$0.00
Overhead	\$0.00	Hours Per Sq Foot	0.00
Profit	\$118.34	Square Feet	0.00
Total Return \$	\$118.34	Job Months	0.00
Total Return %	9.09	Hours per Week	40.00
Price	\$1,301.77	Workers Per Day	0.00
Bond	\$0.00	Total Hours	8.58
Sell Price	\$1,301.77	Mark Up Sales Tax? Yes	
Sell Adjusted By:	\$0.00	Use Bond Table? No	
Adj Sell Return	0		\$0.00

Labor	Percent	Hours	Hourly	Burden		Labor Cost
ClassDescription	of Total	Distributed	Rate	Rate	Percent	Labor Cost
	100.00%	8.58	\$45.00	\$0.00	0.00%	\$386.26
Totals:	100.00%	8.58	\$45.00	\$0.00	0.00%	\$386.26

MARK UPS						
	OVERHEAD			PROFIT		
	Total	%	Amount	%	Amount	Amount
Materials	\$87.72	0.00%	\$87.72	10.00%	\$96.49	
Labor	\$386.26	0.00%	\$386.26	10.00%	\$424.88	
Supplier Quotes	\$688.50	0.00%	\$688.50	10.00%	\$757.35	
SubContractors	\$0.00	0.00%	\$0.00	10.00%	\$0.00	
Direct Job Expense	\$0.00	0.00%	\$0.00	10.00%	\$0.00	
Equipment Rental	\$0.00	0.00%	\$0.00	10.00%	\$0.00	
Totals:	\$1,162.48	0.00%	\$1,162.48	10.00%	\$1,278.72	

TAX Report			
	Taxed Amount	Tax Rate %	Tax Amount
Materials	\$87.72	6.00%	\$5.26
Labor	\$386.26	0.00%	\$0.00
Supplier Quotes	\$261.50	6.00%	\$15.69
SubContractors	\$0.00	6.00%	\$0.00
Direct Job Expense	\$0.00	6.00%	\$0.00
Equipment Rental	\$0.00	6.00%	\$0.00
	Total Tax:		\$20.95

Supplier Quotes

BID SUMMARY REPORT

Name: Utility Maintenance Facility

Estimator: Admin

Job #: 60

Name	Supplier	Tax (6%)	Unit	Multiplier	Dollars
Fire Alarm Equipment	Johnson	No	\$427.00	1.00	\$427.00
Relay	cres	Yes	\$261.50	1.00	\$261.50
Total:					\$688.50

Items

Item #	Item Name	Quantity	Crescent u	BSE u	Price 1 u	Ext Price 1	Bid Lbr u	Bid Lbr Ext	CCode
11	12 THHN CU STRAND	157.50	\$.00 E	\$.00 E	\$153.12 M	\$24.12	4.00 M	.63	wb
1,060	1/2 EMT	50.00	\$.00 E	\$.00 E	\$40.37 C	\$20.18	2.00 C	1.00	cb
1,061	3/4 EMT	20.00	\$.00 E	\$.00 E	\$63.22 C	\$12.64	3.00 C	.60	cb
1,142	3/4 EMT CONN D/C	4.00	\$.00 E	\$.00 E	\$116.69 C	\$4.67	5.00 C	.20	cb
1,165	1/2 EMT CONN S/S	5.00	\$.00 E	\$.00 E	\$25.19 C	\$1.26	4.00 C	.20	cb
1,237	1/2 EMT COUP S/S	5.00	\$.00 E	\$.00 E	\$33.44 C	\$1.67	3.00 C	.15	cb
1,332	1/2 EMT 1 HOLE STP/	6.25	\$.00 E	\$.00 E	\$41.90 C	\$2.62	3.00 C	.19	cb
1,333	3/4 EMT 1 HOLE STP/	4.00	\$.00 E	\$.00 E	\$56.00 C	\$2.24	3.00 C	.12	cb
2,984	3/4 BUSH PLASTIC	4.00	\$.00 E	\$.00 E	\$43.04 C	\$1.72	4.90 C	.20	cb
3,833	10 X 1-1/2 COMB PA	6.25	\$.00 E	\$.00 E	\$2.03 C	\$.13	.00 X	.00	ch
3,895	1/4 FLAT STEEL WAS	6.25	\$.00 E	\$.00 E	\$58.32 C	\$3.65	.00 X	.00	ch
21,229	FA 14/2 RED CABLE	50.00	\$.00 E	\$.00 E	\$256.49 M	\$12.82	16.00 M	.80	mc
47,461	1 HOUR LABOR (MIS	4.50	\$.00 X	\$.00 X	\$.00 X	\$.00	1.00 E	4.50	am
100,007	FA Device	1.00	\$.00 E	\$.00 E	\$.00 Q	\$.00	.00 X	.00	lf
100,012	Stub up deviced 2 hr	1.00	\$.00 E	\$.00 E	\$.00 Q	\$.00	.00 X	.00	lf
Totals						\$87.72		8.58	



Proposal

To: Al Sutton Electric

September 16, 2014

**Project: RC Utility Maintenance Facility
RFP-06 Fire Alarm System**

Johnson Controls, Inc. (JCI) has reviewed RFP-06 and has provided the following proposal. JCI will furnish all fire alarm related equipment for this project in addition to the labor associated with the programming, testing and commissioning. Please see the bill of materials as listed below.

RFP-06 Fire Alarm System:

\$ 427.00

RFP-06 - Fire Alarm System - Bill of Materials:

<u>Qty.</u>	<u>Model #</u>	<u>Description</u>
+2	M300RJ	Addressable Relay Module
+1	LOT	Labor, Programming, Testing, and Commissioning

Our proposed Fire Alarm System Option does NOT include the following:

- Electrical installation, cable, field device terminations
- Central Station Monitoring Fee
- Two phone lines
- Excise Tax (to be furnished by the GC)

Sales tax included

Payment Terms: Net45

QUOTATION - PRICES SUBJECT TO CHANGE
 - QUANTITIES AVAILABLE SUBJECT TO PRIOR SALE

CRESCENT ELECTRIC SUPPLY CO
 317 MAPLE AVE
 RAPID CITY, SD 577012941

Phone: 605-342-7913
 FAX: 605-342-7278

Sales Order Nr: 015-929137-00
 Purchase Order: AL
 Order Date: 12/17/14 By KCH725
 Req Ship Date: 12/18/14

Customer: 255661-00
 AL SUTTON ELEC
 PO BOX 3538
 RAPID CITY, SD 577093538

Ship To: AL SUTTON ELEC
 2017 E HWY 44
 RAPID CITY, SD 577032234

Ordered By: AL
 Ship VIA: BEST WAY

Line Order Qty	Avail	BO Qty	Type	Product Description	Unit Price	Extension
1	1			CESCO# 152529 D26MR20B ETN	243.84/E	243.84
2	1			CESCO# 079650 ASEB8X6NK HOFF-E PULL BOX 8.00X8.0	17.66/E	17.66
Merchandise Total						261.50
Freight Charge						
Other Charges						15.69
Tax (SD11)						
Invoice Total						277.19



AIA[®]

Document G709™ – 2001

Work Changes Proposal Request

PROJECT (Name and address):
Rapid City Utility Maintenance
Facility
Rapid City, South Dakota

PROPOSAL REQUEST NUMBER: 006

OWNER:

ARCHITECT:

CONSULTANT:

CONTRACTOR:

FIELD:

OTHER:

OWNER (Name and address):
City of Rapid City
300 6th Street
Rapid City, SD 57701

DATE OF ISSUANCE: December 11, 2014

CONTRACT FOR: General Construction

CONTRACT DATE: September 17, 2014

FROM ARCHITECT (Name and address):

ARCHITECT'S PROJECT NUMBER: 13373

Upper Deck Architects, Inc.
50 Minnesota Street
Suite 1
Rapid City, SD 57701

TO CONTRACTOR (Name and address):

SECO Construction
P.O. Box 2921
Rapid City, SD

Please submit an itemized proposal for changes in the Contract Sum and Contract Time for proposed modifications to the Contract Documents described herein. Within seven (7) days, the Contractor must submit this proposal or notify the Architect, in writing, of the date on which proposal submission is anticipated.

THIS IS NOT A CHANGE ORDER, A CONSTRUCTION CHANGE DIRECTIVE OR A DIRECTION TO PROCEED WITH THE WORK DESCRIBED IN THE PROPOSED MODIFICATIONS.

DESCRIPTION (Insert a written description of the Work):

Provide HVLS Fan Shutdown per attached Skyline Engineering description

ATTACHMENTS (List attached documents that support description):

Skyline Engineering RFP #6

REQUESTED BY THE ARCHITECT

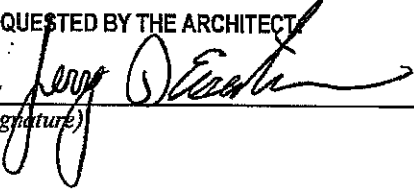
(Signature)

Jerry Eisenbraun, Project Manager
(Printed name and title)

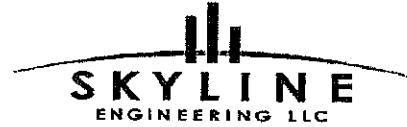

Proposal Request

Date:	12-10-14	PR No.:	RFP # 6
To:	Jerry Eisenbraun	Issue:	HVLS Fans Shutdown
Copy:	Andy Anderson	Owner:	City of Rapid City
From:	Allen Freeland/ Robert Galpin	Architect:	Upper Deck Architects
Project:	RC Utility Maintenance	Skyline PM:	Andy Anderson
Skyline Project No.:	13028	General Contractor:	SECO Const.

Please submit an itemized proposal for changes in the Contract Sum and Contract Time for proposed modifications to the Contract Documents described herein.

All work shall be in accordance with the most recent issue of the Drawings and Specifications.

THIS IS NOT A CHANGE ORDER, A CONSTRUCTION CHANGE DIRECTIVE OR A DIRECTION TO PROCEED WITH THE WORK DESCRIBED IN THE PROPOSED MODIFICATIONS.

Background: Code Changes and City Requirement for High Volume Low Speed (HVLS) fans to be shutdown on any fire alarm or sprinkler flow so as not to impede the sprinkler spray pattern.

Description: Provide a detailed breakdown per the contract specifications for the following changes to the work.

Electrical:

1. Sheet E-202 Mezzanine Power Plan
 - a. Provide a line voltage, 2-pole, 20A relay, conduit, wire, boxes, etc. to cut power to DF1 & DF2 fan controller for fan shutdown on any fire alarm event or supervisory condition. Coordinate interconnection shutdown with fan supplier and MC.
2. Sheet E-301 Main Level Signal Plan
 - a. Provide a fire alarm control module, conduit, wire, boxes, etc. to control the line-voltage relay from the FACP as a FACP fan shutdown. Coordinate interconnection with fan supplier, MC and fire alarm subcontractor.

Attachment(s): None

Requested By:

Robert Galpin
Electrical

RFP #007



UPPER DECK
ARCHITECTS, INC.

50 MINNESOTA ST. - SUITE 1
RAPID CITY, SD 57701
PH: 605 721-0237
FAX: 605 721-0240

RFP #007 RECOMMENDATION



UPPER DECK
ARCHITECTS, INC.

50 MINNESOTA ST. - SUITE 1
RAPID CITY, SD 57701
PH: 605 721-0237
FAX: 605 721-0240

To: Rod Johnson

Project: Rapid City Utility Maintenance Facility Project #: 13373

From: Jerry D. Eisenbraun Date: 12/29/2014

Content: RFP #007 Recommendation

Rod:

Attached is the pricing information from SECO Construction, Inc. for Proposal Request No. 7 – Raise Mezzanine Floor. This change allows for an increase in ceiling plenum space for routing of M/E piping and ductwork. Work required of this RFP has been coordinated with current work and with precast shop drawings in order to minimize cost impact. We have reviewed and find to be commensurate with the work required.

We recommend acceptance of RFP #007 for a cost **add of \$4,574.00**. If this is acceptable, please forward to us your decision regarding this item, and we will ensure this is incorporated into the next change order.

Sincerely,
Jerry D. Eisenbraun



P.O. BOX 2921 RAPID CITY, SD 57709 (605)348-7085 FAX (605)348-8287

December 23, 2014

VIA EMAIL

Mr. Jerry Eisenbraun
Upper Deck Architects, Inc.
50 Minnesota Street, Suite 1
Rapid City, SD 57701

Subject: Proposal for RFP #7, Rapid City Utility Maintenance Facility, Rapid City, SD

Dear Jerry,

We propose to provide the mezzanine revisions as outlined in Request for Proposal #7 dated December 17, 2014 for an additional cost of \$4,574.00. The estimate cost summary sheet for this work and associated documentation are enclosed for your review.

The work outlined in this proposal has proceeded per your written direction. Please confirm acceptance of this proposal and include this work in the next contract change order.

Sincerely,
SECO Construction, Inc.

A handwritten signature in black ink, appearing to read "Neal A. Schlottman", is written over a horizontal line.

Neal A. Schlottman
President

enclosures



SECO Construction, Inc.
REQUEST FOR PROPOSAL COST SUMMARY
Rapid City Utility Maintenance Facility

Proposal Request No. 7

<u>Subcontractors</u>	<u>Work Description</u>	<u>Amount</u>
Singer Masonry	Additional CMU	2,732.00
All Metal Manufacturing	Additional Rebar, Revised Columns, Stairs and Handrails	1,098.00
SUBCONTRACTOR SUBTOTAL		3,830.00
<u>GC Labor</u>		
Project Manager and Superintendent		120.00
Additional Concrete Stair Pans		50.00
LABOR SUBTOTAL		170.00
<u>GC Materials</u>		
Concrete and Concrete Accessories at Stair Pans		10.00
MATERIAL SUBTOTAL		10.00
Sales Tax	6.00%	0.60
LABOR SUBTOTAL		170.00
GC Overhead	8%	14.45
SUBCONTRACTOR TOTAL		3,830.00
SUBTOTAL		4,025.05
GC Profit	10%	402.50
SUBTOTAL		4,427.55
Bond/Insurance	1.25%	55.34
State Excise Tax	2.041%	91.50
TOTAL		4,574.39
TOTAL THIS PROPOSAL		\$ 4,574



Singer Masonry, Inc.

2261 S. Plaza Drive
Rapid City, SD 57702
(605) 343-9161 Phone
(605) 343-0362 Fax

Change Order #1

Date: December 15, 2014

Project: Rapid City Utility Maintenance Facility
Rapid City, SD

Mezzanine Modification

Labor and materials to lay (1) additional course of 8" block in the mezzanine area.

For the Sum of \$ 2,732.00

Materials:	Approximately 300' of 8" block, mortar, concrete for verticals 2' on center, durwall.	995.00
Labor:	(4) Masons at \$45.00/hour (6 hrs)	1,080.00
	(2) Laborers at \$25.00/hour (6 hrs)	300.00
Overhead:	172.00
Profit:	185.00

Excludes:	Demolition	Lintels
	Permits	Rebar
	Door or Window Frames	Drilling & Epoxing Rebar
	Louvers	All Building Wrap
	Testing	Angle Irons
	Water on site	Bolts
	Winter Heat or Tenting	
	Masonry Sealer (interior & exterior)	2% Excise Taxes

Sincerely,
Alan Singer
Alan Singer,
Vice President

Acceptance of this bid within 30 days will guarantee this price.

ALL METAL MANUFACTURING, INC.

4290 Universal Drive ❖ Rapid City, South Dakota 57702 ❖ (605) 787-4677 ❖ FAX (605) 787-4796

December 23, 2014

TO: Seco Construction
RE : RC Utility maintenance

REP #7

ESTIMATE FOR:

- Misc Rebar for masonry
- Shorten Columns
- Add additional length to 2 stairways, and handrail

BID: \$1050.00 + \$48.⁰⁰ SALES TAX ON MATERIALS
PER TORI 12-23-14

We EXCLUDE:
All Sales and Excise Taxes

= \$1098.⁰⁰

Thank you,



All Metal Manufacturing, Inc.

ALL PAINTING/POWDER COATING ON RAILINGS/BANDBARSIS WARENTED FOR A ONE YEAR PERIOS AFTER INSTALLATION
All material used in this contract is guaranteed to be as specified, and the entire job is to be done in a neat and substantial manner.

Any alteration or deviation from the specifications herein agreed upon involving extra cost of labor and material will be executed only upon orders for same, and will become an extra charge over the sum mentioned in this contract.

Purchaser agrees that seller is entitled to reasonable attorney's fees, with or without suit, and all costs of suit if the purchaser's account is referred to an attorney for collection.

ACCEPTANCE OF ESTIMATE

The following terms, specifications and conditions are satisfactory, and the same are hereby accepted and agreed upon, and you are hereby authorized to execute the same.

Date

Signed

This Contract is void 30 days from date unless signed and returned to bidder.



Document G709™ – 2001

Work Changes Proposal Request

PROJECT (Name and address):
Rapid City Utility Maintenance
Facility
Rapid City, South Dakota

PROPOSAL REQUEST NUMBER: 007

OWNER:

ARCHITECT:

DATE OF ISSUANCE: December 17, 2014

CONSULTANT:

OWNER (Name and address):
City of Rapid City
300 6th Street
Rapid City, SD 57701

CONTRACT FOR: General Construction

CONTRACTOR:

FIELD:

CONTRACT DATE: September 17, 2014

OTHER:

FROM ARCHITECT (Name and address):
Upper Deck Architects, Inc.
50 Minnesota Street
Suite 1
Rapid City, SD 57701

ARCHITECT'S PROJECT NUMBER: 13373

TO CONTRACTOR (Name and address):
SECO Construction
P.O. Box 2921
Rapid City, SD

Please submit an itemized proposal for changes in the Contract Sum and Contract Time for proposed modifications to the Contract Documents described herein. Within seven (7) days, the Contractor must submit this proposal or notify the Architect, in writing, of the date on which proposal submission is anticipated.

THIS IS NOT A CHANGE ORDER, A CONSTRUCTION CHANGE DIRECTIVE OR A DIRECTION TO PROCEED WITH THE WORK DESCRIBED IN THE PROPOSED MODIFICATIONS.

DESCRIPTION (Insert a written description of the Work):

Provide costs associated with raising mezzanine floor 8" from elevation 110'-3" to 110'-11". Change of floor height will require modification to stair stringer and handrails, relocation of door and stoop at 123A and reduction in steel column height. The three masonry lintels shall be raised 8" as shown on attached drawing A2. Modification has been coordinated with precast shop drawings.

ATTACHMENTS (List attached documents that support description):

A1, A2, A3

REQUESTED BY THE ARCHITECT:

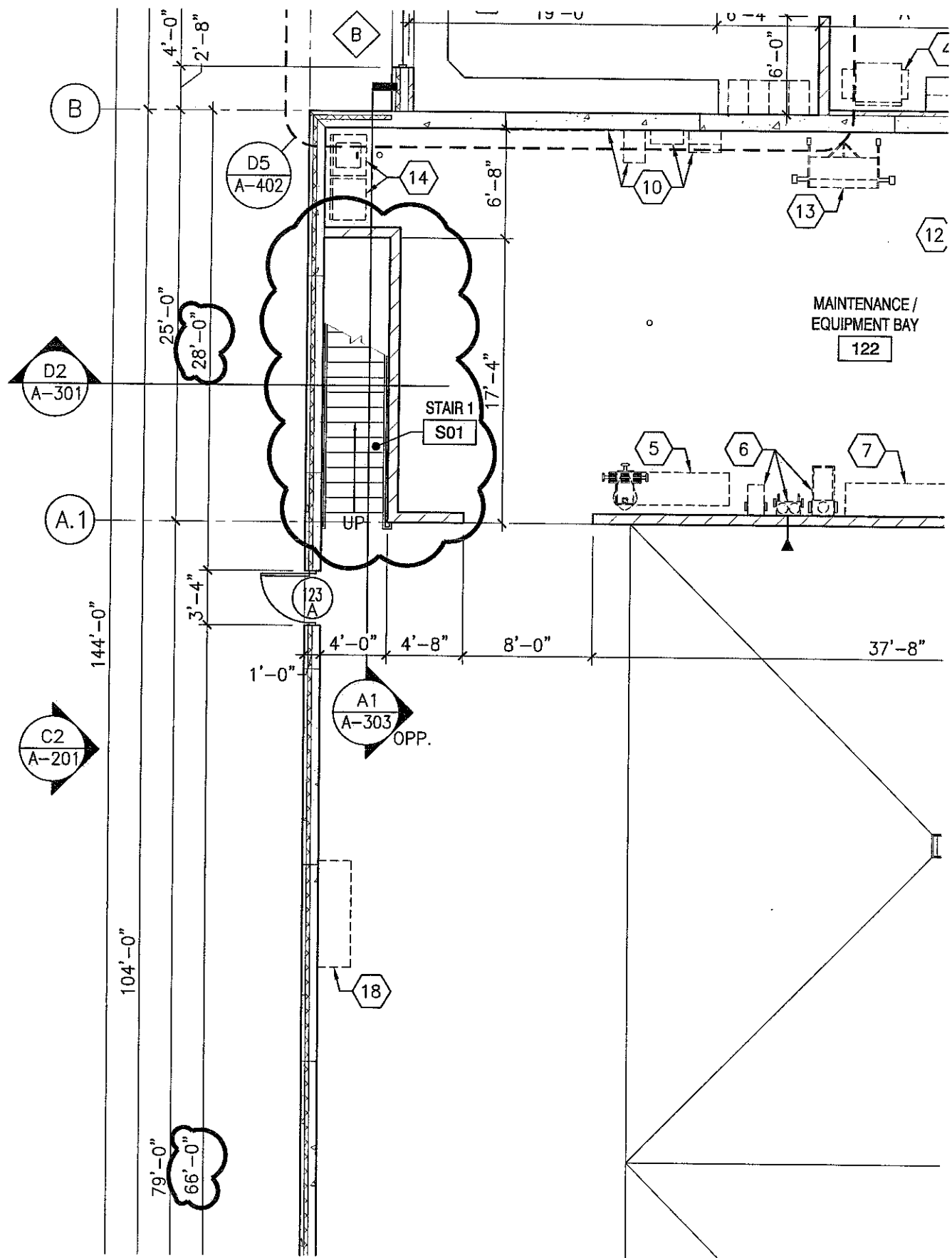

(Signature)

Jerry Eisenbraun, Project Manager
(Printed name and title)

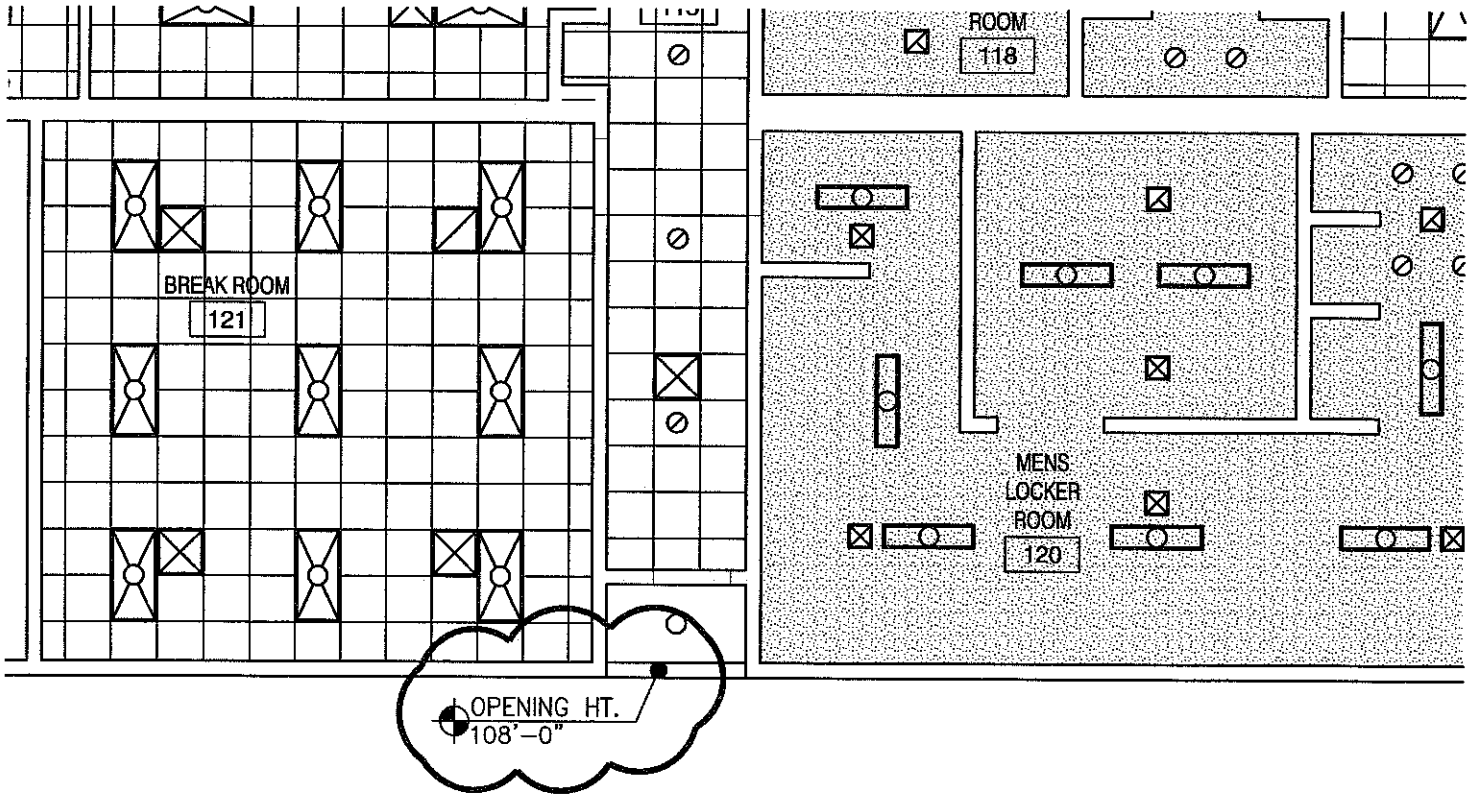
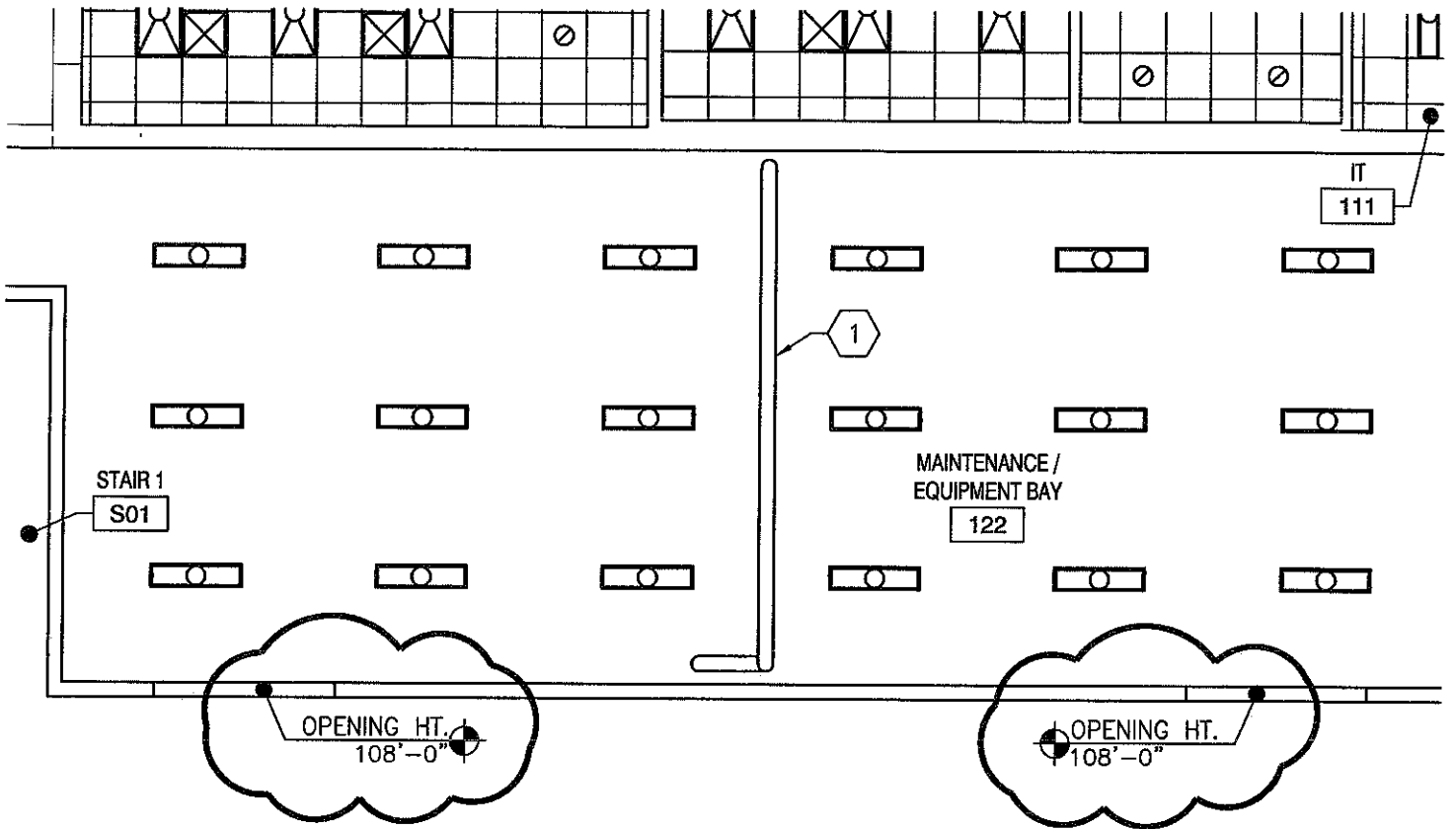

 50 MINNESOTA ST. - SUITE 1
 RAPID CITY, SD 57701
 PH: 605 721-0237
 FAX: 605 721-0240
UPPER DECK
 ARCHITECTS, INC.

RFP #: 7	CITY OF RAPID CITY UTILITY MAINTENANCE FACILITY	13373	A1
REVISED FIRST FLOOR PLAN - B1/A-101			
Scale: 1/8" = 1'-0"	DATE: 12/10/14		



RFP #: 7	CITY OF RAPID CITY UTILITY MAINTENANCE FACILITY	13373
REVISED FIRST FLOOR REFLECTED CEILING PLAN - B1/A-103		
Scale: 1/8" = 1'-0"	DATE: 12/10/14	A2

NOTE:
POWDERCOAT
RAILING &
HANDRAIL
"SAFETY YELLOW"

1/2" PIPE
RAILING
WALL BEYOND

1'-0" TYP.
18 TREADS @ 11" = 18'-6"

STAIR 2
S02

C4
TYP. A-502

1/2" Ø METAL
HANDRAIL
CONC. FILLED
METAL PAN
TREADS

3'-0"

6'-11"

1'-0" TYP.

MEZZANINE
201

CONC. TOPPING
PRE-CAST HOLLOW
CORE CONC. PLANK

CONTINUOUS OPEN
CORE BOND
BEAM/LINTEL @
HEADERS-COORD.
LOCATIONS
REINFORCED 8"

MECHANICAL/
ELECTRICAL
119

ISOLATION JOINT
W/ SEALANT
CONC. SLAB ON
GRADE

F.F.E.
MEZZANINE
110-11

19 EQ. RISERS = 10'-11"

F.F.E.
FIRST FLOOR
100-0

CONC. FOOTING

RETURN HANDRAIL
TO WALL



RFP #: 7
CITY OF RAPID CITY UTILITY MAINTENANCE FACILITY
13373
A3
REVERSED STAIR SECTION - A1/A-303
Scale: 1/2" = 1'-0"
DATE: 12/10/14

RFP #008



UPPER DECK
ARCHITECTS, INC.

50 MINNESOTA ST. - SUITE 1
RAPID CITY, SD 57701
PH: 605 721-0237
FAX: 605 721-0240

Jerry D. Eisenbraun

From: Johnson Rod <Rod.Johnson@rcgov.org>
Sent: Tuesday, December 23, 2014 8:25 AM
To: Jerry D. Eisenbraun
Cc: Neal Schlottman
Subject: RE: RCUMF RFP Recommendations

Proposal #6 and #8 are acceptable. Please include in the next change order.

RJ

From: Jerry D. Eisenbraun [<mailto:jerrye@upperdeckarchitects.com>]
Sent: Monday, December 22, 2014 4:46 PM
To: Johnson Rod
Subject: RCUMF RFP Recommendations

Rod,

Attached are our recommendations for RFPs #6 and #8. Please note both of these have a response deadline before additional days need to be considered.

Jerry D. Eisenbraun
Project Manager

UPPER DECK ARCHITECTS, INC.

50 Minnesota Street - Suite 1

Rapid City, SD 57701

PH (605) 721-0237

FX (605) 721-0240

Visit us at: www.upperdeckarchitects.com

RFP #008 RECOMMENDATION



UPPER DECK
ARCHITECTS, INC.

50 MINNESOTA ST. - SUITE 1
RAPID CITY, SD 57701
PH: 605 721-0237
FAX: 605 721-0240

To: Rod Johnson

Project: Rapid City Utility Maintenance Facility Project #: 13373

From: Jerry D. Eisenbraun Date: 12/22/2014

Content: RFP #008 Recommendation

Rod:

Attached is the pricing information from SECO Construction, Inc. for Proposal Request No. 8 – Omit clean rock at overhead doors. Clean rock is being omitted as we are now utilizing engineering fill along west, south and east elevation that include these areas. We and our consultants have reviewed and find to be commensurate with the work required.

We recommend acceptance of RFP #008 for a cost **credit of (\$1,690.00)**. If this is acceptable, please forward to us your decision regarding this item, and we will ensure this is incorporated into the next change order. Please note deadline for approval before additional time needs to be considered.

Sincerely,
Jerry D. Eisenbraun



P.O. BOX 2921 RAPID CITY, SD 57709 (605)348-7085 FAX (605)348-8287

December 22, 2014

VIA EMAIL

Mr. Jerry Eisenbraun
Upper Deck Architects, Inc.
50 Minnesota Street, Suite 1
Rapid City, SD 57701

Subject: Proposal for RFP #8, Rapid City Utility Maintenance Facility, Rapid City, SD

Dear Jerry,

We propose to delete the clean rock backfill at the overhead doors as outlined in Request for Proposal #8 dated December 11, 2014 for a cost deduct of \$1,690.00. The estimate cost summary sheet for this work and associated documentation are enclosed for your review.

The work outlined in this proposal request will not require a contract time change if we receive written notice to proceed on this proposal no later than January 2, 2015.

Sincerely,
SECO Construction, Inc.

A handwritten signature in black ink, appearing to read "Neal A. Schlottman".

Neal A. Schlottman
President

enclosures



SECO Construction, Inc.
 REQUEST FOR PROPOSAL COST SUMMARY
 Rapid City Utility Maintenance Facility

Proposal Request No. 8

<u>Subcontractors</u>	<u>Work Description</u>	<u>Amount</u>
Iron Horse Excavating	Delete Clean Rock at Overhead Doors	(1,636.00)
SUBCONTRACTOR SUBTOTAL		(1,636.00)
<u>GC Labor</u>		
LABOR SUBTOTAL		-
<u>GC Materials</u>		
MATERIAL SUBTOTAL		-
Sales Tax	6.00%	-
LABOR SUBTOTAL		-
GC Overhead	8%	-
SUBCONTRACTOR TOTAL		(1,636.00)
SUBTOTAL		(1,636.00)
GC Profit	10%	-
SUBTOTAL		(1,636.00)
Bond/Insurance	1.25%	(20.45)
State Excise Tax	2.041%	(33.81)
TOTAL		(1,690.26)
TOTAL THIS PROPOSAL		\$ (1,690)

IRON HORSE EXCAVATING, INC.

Rapid City, SD 57702

Estimate

DATE	ESTIMATE NO.
12/22/2014	RFP #8

NAME / ADDRESS
SECO Construction Attn : Neal Re: Rapid City Maint. Bld.

PROJECT

DESCRIPTION	QTY	COST	TOTAL
Delete clean rock from overhead doors as follows.		0.00	0.00
3/4 " clean rock	92	8.00	736.00
Bobcat hourly rate	6	70.00	420.00
Dump truck hourly rate	6	80.00	480.00
Sales Tax		4.00%	0.00
		TOTAL	\$1,636.00



Document G709™ – 2001

Work Changes Proposal Request

PROJECT *(Name and address):*
Rapid City Utility Maintenance
Facility
Rapid City, South Dakota

PROPOSAL REQUEST NUMBER: 008

OWNER:

ARCHITECT:

DATE OF ISSUANCE: December 11, 2014

CONSULTANT:

OWNER *(Name and address):*
City of Rapid City
300 6th Street
Rapid City, SD 57701

CONTRACT FOR: General Construction

CONTRACTOR:

CONTRACT DATE: September 17, 2014

FIELD:

OTHER:

FROM ARCHITECT *(Name and address):*
Upper Deck Architects, Inc.
50 Minnesota Street
Suite 1
Rapid City, SD 57701

ARCHITECT'S PROJECT NUMBER: 13373

TO CONTRACTOR *(Name and address):*
SECO Construction
P.O. Box 2921
Rapid City, SD

Please submit an itemized proposal for changes in the Contract Sum and Contract Time for proposed modifications to the Contract Documents described herein. Within seven (7) days, the Contractor must submit this proposal or notify the Architect, in writing, of the date on which proposal submission is anticipated.

THIS IS NOT A CHANGE ORDER, A CONSTRUCTION CHANGE DIRECTIVE OR A DIRECTION TO PROCEED WITH THE WORK DESCRIBED IN THE PROPOSED MODIFICATIONS.

DESCRIPTION *(Insert a written description of the Work):*

Provide cost credit to omit 3/4" clean rock at thirteen (13) overhead doors as noted per detail 2, sheet S-301. Utilization of engineered fill as directed on 12/8/2014 eliminates this requirement.

ATTACHMENTS *(List attached documents that support description):*

REQUESTED BY THE ARCHITECT:

(Signature)

Jerry Eisenbraun, Project Manager
(Printed name and title)



RFP #009



UPPER DECK
ARCHITECTS, INC.

50 MINNESOTA ST. - SUITE 1
RAPID CITY, SD 57701
PH: 605 721-0237
FAX: 605 721-0240

Jerry D. Eisenbraun

From: Johnson Rod <Rod.Johnson@rcgov.org>
Sent: Monday, December 29, 2014 10:00 AM
To: Jerry D. Eisenbraun
Cc: Neal Schlottman; Van Cleave Dave; Wagner John
Subject: RE: RCUMF RFP #009 Recommendation

Proposal #9 is acceptable. Please include it in the next change order.

RJ

From: Jerry D. Eisenbraun [<mailto:jerrye@upperdeckarchitects.com>]
Sent: Monday, December 29, 2014 9:39 AM
To: Johnson Rod
Subject: RCUMF RFP #009 Recommendation

Rod,
Attached is our recommendation to omit the dampproofing per RFP #009.

Jerry D. Eisenbraun
Project Manager

UPPER DECK ARCHITECTS, INC.

50 Minnesota Street - Suite 1
Rapid City, SD 57701
PH (605) 721-0237 FX (605) 721-0240
Visit us at: www.upperdeckarchitects.com

RFP #009 RECOMMENDATION



UPPER DECK
ARCHITECTS, INC.

50 MINNESOTA ST. - SUITE 1
RAPID CITY, SD 57701
PH: 605 721-0237
FAX: 605 721-0240

To: Rod Johnson

Project: Rapid City Utility Maintenance Facility

Project #: 13373

From: Jerry D. Eisenbraun

Date: 12/29/2014

Content: RFP #009 Recommendation

Rod:

Attached is the pricing information from SECO Construction, Inc. for Proposal Request No. 9 – Omit dampproofing at foundation walls. Dampproofing was omitted as no occupied spaces occur. We have reviewed and find to be commensurate with the work required.

We recommend acceptance of RFP #009 for a cost **credit of (\$2,686.00)**. If this is acceptable, please forward to us your decision regarding this item, and we will ensure this is incorporated into the next change order. Please note deadline for approval before additional time needs to be considered.

Sincerely,
Jerry D. Eisenbraun



P.O. BOX 2921 RAPID CITY, SD 57709 (605)348-7085 FAX (605)348-8287

December 23, 2014

VIA EMAIL

Mr. Jerry Eisenbraun
Upper Deck Architects, Inc.
50 Minnesota Street, Suite 1
Rapid City, SD 57701

Subject: Proposal for RFP #9, Rapid City Utility Maintenance Facility, Rapid City, SD

Dear Jerry,

We propose to delete the bituminous dampproofing and protection board as outlined in Request for Proposal #9 dated December 11, 2014 for a cost deduct of \$2,686.00. The estimate cost summary sheet for this work and associated documentation are enclosed for your review.

The work outlined in this proposal request was deleted from the project and not installed based on your verbal direction. Please confirm acceptance of this proposal and include it in the next contract change order.

Sincerely,
SECO Construction, Inc.

A handwritten signature in black ink, appearing to read "Neal A. Schlottman", written over a horizontal line.

Neal A. Schlottman
President

enclosures



SECO Construction, Inc.
 REQUEST FOR PROPOSAL COST SUMMARY
 Rapid City Utility Maintenance Facility

Proposal Request No. 9

<u>Subcontractors</u>	<u>Work Description</u>	<u>Amount</u>
Dakota Sealants, Inc.	Delete Dampproofing and Protection Board	(2,600.00)
SUBCONTRACTOR SUBTOTAL		(2,600.00)
<u>GC Labor</u>		
LABOR SUBTOTAL		-
<u>GC Materials</u>		
MATERIAL SUBTOTAL		-
Sales Tax	6.00%	-
LABOR SUBTOTAL		-
GC Overhead	8%	-
SUBCONTRACTOR TOTAL		(2,600.00)
SUBTOTAL		(2,600.00)
GC Profit	10%	-
SUBTOTAL		(2,600.00)
Bond/Insurance	1.25%	(32.50)
State Excise Tax	2.041%	(53.73)
TOTAL		(2,686.23)
TOTAL THIS PROPOSAL		\$ (2,686)



AIA[®]

Document G709™ – 2001

Work Changes Proposal Request

PROJECT *(Name and address):*
Rapid City Utility Maintenance
Facility
Rapid City, South Dakota

PROPOSAL REQUEST NUMBER: 009

OWNER:

ARCHITECT:

CONSULTANT:

CONTRACTOR:

FIELD:

OTHER:

OWNER *(Name and address):*
City of Rapid City
300 6th Street
Rapid City, SD 57701

DATE OF ISSUANCE: December 11, 2014

CONTRACT FOR: General Construction

CONTRACT DATE: September 17, 2014

FROM ARCHITECT *(Name and address):*

ARCHITECT'S PROJECT NUMBER: 13373

Upper Deck Architects, Inc.
50 Minnesota Street
Suite 1
Rapid City, SD 57701

TO CONTRACTOR *(Name and address):*

SECO Construction
P.O. Box 2921
Rapid City, SD

Please submit an itemized proposal for changes in the Contract Sum and Contract Time for proposed modifications to the Contract Documents described herein. Within seven (7) days, the Contractor must submit this proposal or notify the Architect, in writing, of the date on which proposal submission is anticipated.

THIS IS NOT A CHANGE ORDER, A CONSTRUCTION CHANGE DIRECTIVE OR A DIRECTION TO PROCEED WITH THE WORK DESCRIBED IN THE PROPOSED MODIFICATIONS.

DESCRIPTION *(Insert a written description of the Work):*

Provide cost credit to omit foundation dampproofing and protection board as noted on architectural wall sections and specifications section 07 1113. Dampproofing is being omitted as there is no occupied spaces, crawl space or basement.

ATTACHMENTS *(List attached documents that support description):*

REQUESTED BY THE ARCHITECT

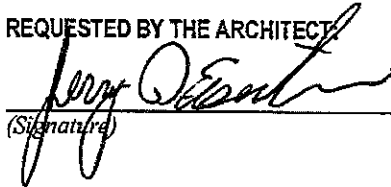

(Signature)

Jerry Eisenbraun, Project Manager

(Printed name and title)

RFP #010



UPPER DECK
ARCHITECTS, INC.

50 MINNESOTA ST. - SUITE 1
RAPID CITY, SD 57701
PH: 605 721-0237
FAX: 605 721-0240

Jerry D. Eisenbraun

From: Johnson Rod <Rod.Johnson@rcgov.org>
Sent: Friday, January 09, 2015 10:04 AM
To: Jerry D. Eisenbraun; Neal Schlottman
Subject: RE: RCUMF RFP #010 Recommendation

Proposal #010 is acceptable. Please include it in the next change order.

RJ

From: Jerry D. Eisenbraun [<mailto:jerrye@upperdeckarchitects.com>]
Sent: Thursday, January 08, 2015 3:50 PM
To: Johnson Rod
Subject: RCUMF RFP #010 Recommendation

Rod,
Attached is our recommendation for RFP #010 for your review and consideration.

Jerry D. Eisenbraun
Project Manager

UPPER DECK ARCHITECTS, INC.

50 Minnesota Street - Suite 1
Rapid City, SD 57701
PH (605) 721-0237 FX (605) 721-0240
Visit us at: www.upperdeckarchitects.com

RFP #010 RECOMMENDATION



UPPER DECK
ARCHITECTS, INC.

50 MINNESOTA ST. - SUITE 1
RAPID CITY, SD 57701
PH: 605 721-0237
FAX: 605 721-0240

To: Rod Johnson

Project: Rapid City Utility Maintenance Facility Project #: 13373

From: Jerry D. Eisenbraun Date: 1/8/2015

Content: RFP #010 Recommendation

Rod:

Attached is the pricing information from SECO Construction, Inc. for Proposal Request No. 10 – Modify chain hoist / trolley. Per discussion at construction progress meeting on 1/6/15, it was recommended that the traversing operation of the trolley did not need to be motorized. We have reviewed and find to be commensurate with the work required.

We recommend acceptance of RFP #010 for a cost **credit of (\$1,637.00)**. If this is acceptable, please forward to us your decision regarding this item, and we will ensure this is incorporated into the next change order. Please note deadline for approval before additional time needs to be considered.

Sincerely,
Jerry D. Eisenbraun



P.O. BOX 2921 RAPID CITY, SD 57709 (605)348-7085 FAX (605)348-8287

January 8, 2015

VIA EMAIL

Mr. Jerry Eisenbraun
Upper Deck Architects, Inc.
50 Minnesota Street, Suite 1
Rapid City, SD 57701

Subject: Proposal for RFP #10, Rapid City Utility Maintenance Facility, Rapid City, SD

Dear Jerry,

We propose to delete the motorized trolley and revise the chain hoist as outlined in Request for Proposal #10 dated January 8, 2015 for a cost deduct of \$1,637.00. The estimate cost summary sheet for this work and associated documentation are enclosed for your review.

The work outlined in this proposal request will not require a contract time change if we receive written notice to proceed on this proposal no later than January 16, 2015.

Sincerely,
SECO Construction, Inc.

A handwritten signature in black ink, appearing to read "Neal A. Schlottman".

Neal A. Schlottman
President

enclosures



SECO Construction, Inc.
 REQUEST FOR PROPOSAL COST SUMMARY
 Rapid City Utility Maintenance Facility

Proposal Request No. 10

<u>Subcontractors</u>	<u>Work Description</u>	<u>Amount</u>
SUBCONTRACTOR SUBTOTAL		-
<u>GC Labor</u>	Hoist Revisions - No Cost Change	-
LABOR SUBTOTAL		-
<u>GC Materials</u>	Cranes Conveyors and Storage Systems (see attached)	(1,495.00)
MATERIAL SUBTOTAL		(1,495.00)
Sales Tax	6.00%	(89.70)
LABOR SUBTOTAL		-
GC Overhead	8%	-
SUBCONTRACTOR TOTAL		-
SUBTOTAL		(1,584.70)
GC Profit	10%	-
SUBTOTAL		(1,584.70)
Bond/Insurance	1.25%	(19.81)
State Excise Tax	2.041%	(32.75)
TOTAL		(1,637.26)
TOTAL THIS PROPOSAL		\$ (1,637)

Cranes Conveyors & Storage Systems, Inc.

5948 53rd Avenue SW
 Fargo, ND 58104

PHONE 701-277-1757
 FAX 701-277-1337
 Cranescss.com

QUOTATION

Estimate #
44175

Sold To	Ship To
Seco Construction PO box 2921 Rapid City, S.D. 57709	

Date	Sales Rep	Terms	Estimated Shipping ARO	FOB	SHIP VIA
	JM	NET 30		ORIGIN	BEST WAY

Part Number	Qty	Description	Price	Total
SNERM010S-S-10	1	1 TON CAPACITY ELECTRIC CHAIN HOIST WITH MOTORIZED TROLLEY 115/1/60 PRIMARY VOLTAGE 10' LIFT 16' PENDANT CONTROL LENGTH CHAIN CONTAINER 14 FEET PER MINUTE LIFTING SPEED 80 FEET PER MINUTE TROLLEY TRAVEL SPEED 30' POWER SUPPLY CABLE THE MODEL # SPECIFIED DOES NOT MATCH THE DESCRIPTION OF THE PRODUCT I USED THE WRITTEN SPECS AND CHANGED THE MODEL # TO MATCH IF YOU HAVE ANY QUESTIONS, COMMENTS OR CONCERNS PLEASE CALL ME	4,750.00	4,750.00T
SNERP0102-15'		1 TON CAPACITY ELECTRIC CHAIN HOIST SINGLE LIFTING SPEED 14 FEET PER MINUTE PRIMARY VOLTAGE 120/1/60 15' LIFT CANVAS CHAIN CONTAINER 11' PENDANT CONTROL LENGTH 30' POWER SUPPLY CABLE MANUAL PUSH TROLLEY THAT WILL FIT THE W12 X 22 BEAM FLANGE WIDTH OF 4.030" THE ORIGINAL HOIST WAS \$ 4,750.00	3,255.00	3,255.00T

JERRY MADSEN	Subtotal
	Sales Tax (0.0%)
	Total

Cranes Conveyors & Storage Systems, Inc.

5948 53rd Avenue SW
 Fargo, ND 58104

PHONE 701-277-1757
 FAX 701-277-1337
 Cranescss.com

QUOTATION

Estimate #
44175

Sold To	Ship To
Seco Construction PO box 292I Rapid City, S.D. 57709	

Date	Sales Rep	Terms	Estimated Shipping ARO	FOB	SHIP VIA
	JM	NET 30		ORIGIN	BEST WAY

Part Number	Qty	Description	Price	Total
		THE NEW HOIST IS	\$ 3,255.00	
		THE DIFFERENCE IN COST IS	\$ - 1,495.00	

JERRY MADSEN	Subtotal
	Sales Tax (0.0%)
	Total



Document G709™ – 2001

Work Changes Proposal Request

PROJECT *(Name and address):*
Rapid City Utility Maintenance
Facility
Rapid City, South Dakota

PROPOSAL REQUEST NUMBER: 010

OWNER:

DATE OF ISSUANCE: January 8, 2015

ARCHITECT:

CONSULTANT:

OWNER *(Name and address):*
City of Rapid City
300 6th Street
Rapid City, SD 57701

CONTRACT FOR: General Construction

CONTRACTOR:

CONTRACT DATE: September 17, 2014

FIELD:

OTHER:

FROM ARCHITECT *(Name and address):*
Upper Deck Architects, Inc.
50 Minnesota Street
Suite 1
Rapid City, SD 57701

ARCHITECT'S PROJECT NUMBER: 13373

TO CONTRACTOR *(Name and address):*
SECO Construction
P.O. Box 2921
Rapid City, SD

Please submit an itemized proposal for changes in the Contract Sum and Contract Time for proposed modifications to the Contract Documents described herein. Within seven (7) days, the Contractor must submit this proposal or notify the Architect, in writing, of the date on which proposal submission is anticipated.

THIS IS NOT A CHANGE ORDER, A CONSTRUCTION CHANGE DIRECTIVE OR A DIRECTION TO PROCEED WITH THE WORK DESCRIBED IN THE PROPOSED MODIFICATIONS.

DESCRIPTION *(Insert a written description of the Work):*

Provide cost credit to provide SNER electric chain hoist/trolley model SNERP-010S in lieu of model specified. Modification changes transversing operation from power to push, and clarifies lift height and control cord length.

ATTACHMENTS *(List attached documents that support description):*

Harrington SNER cut sheet

REQUESTED BY THE ARCHITECT:

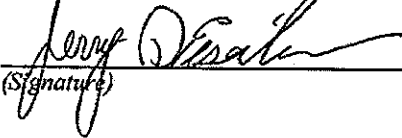
(Signature)

Jerry Eisenbraun, Project Manager
(Printed name and title)

SNER Electric Chain Hoists with Hook and Lug Suspensions and Motorized, Push and Geared Trolleys

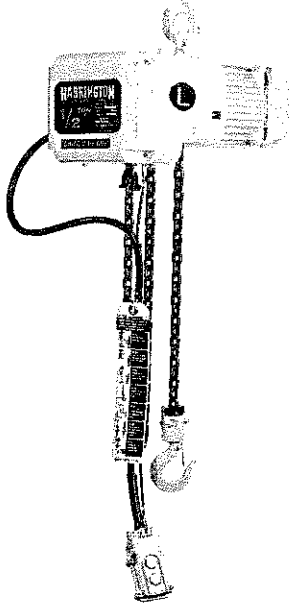

SNER005L

Our SNER Series of electric chain hoists furnishes single-phase operation in a heavy-duty, low-headroom design. Available in hook mount or coupled with a trolley, it easily transports any load. Look to this model when high quality and convenience are important for the job.

Features and Benefits

Extreme Duty Motor

Higher horsepower and top duty ratings provide increased performance.

Pull-Rotor Motor Brake

Extremely durable and reliable, this advanced design has no brake coil to fail.

Unique Chain Guide

Provides quiet and smooth guiding of chain. Easily removed without disassembly of hoist. Heavy cast iron construction for improved wear.

Load Sheave

Deep-groove pockets fully support the load chain, reduces vibration and chain wear and provides a true vertical lift.

Long Life Friction Clutch

Protects hoist from damage and prevents overwinding.

Heat Treated Helical and Spur Gears

Precision machined for long life. Oil bath lubrication results in a quiet, smooth, cool operation.

Completely Sealed Body

Suitable for indoor, outdoor and harsh environments.

Compact Aluminum Body

Die-cast body is lightweight and offers low headroom.

Easy Maintenance Control Panel

Fast on-site access with hinged cover, single swing-out panel and simple layout of controls.

Superior Quality Chain

Grade 80 nickel-plated load chain is heat treated for wear resistance and extended life.

Forged Carbon Steel Hooks

Under excessive loads will open gradually and not fracture. Bottom hook swivels 360 degrees.

Motorized Trolley Side Guide Rollers

Provide smooth trolley motion and reduced wear on wheels and beam.

Motorized Trolley Drop Stops and Rubber Bumpers

Built-in security for the operator and added protection for the equipment and load.

Standard Hoist/Trolley Specifications

Capacity Range

1/4 Ton—3 Ton

Reconnectable Voltage

115/230-1-60

Control Voltage

110V

Duty Cycle*

Hoist—60 Min., Trolley—30 Min.

Classification*

ASME H4, ISO M5 or M4, FEM 2M or 1Am

Ratings

Hoist/Trolley—IP55

Pendant—IP65

Limit Switch

Prevents overwinding/overlifting
Standard upper

Chain Falls

Single fall through 2 Ton

Standard Lengths

Lift—10'

Pendant Drop—4' less than lift

Power Supply—Hoist—15'

Power Supply—Motorized

Trolley—30'

(longer lengths available)

Standard Pendants

Hoist—2 Button,

Hoist/Trolley—4 Button

Momentary contacts

Chain Containers

Optional

Canvas, plastic or steel

Geared Trolley Standard

Hand Chain Drop

2' less than lift

(longer drops available)

Trolley Shafts

Standard shafts fit wide

flange range

Longer shafts for wider beams

Spacers for easy adjustments

Trolley Wheels

All steel

Shielded ball bearings

Fit flat or tapered beam flange

*See page 56 for additional information.

HARRINGTON ELECTRIC CHAIN HOISTS

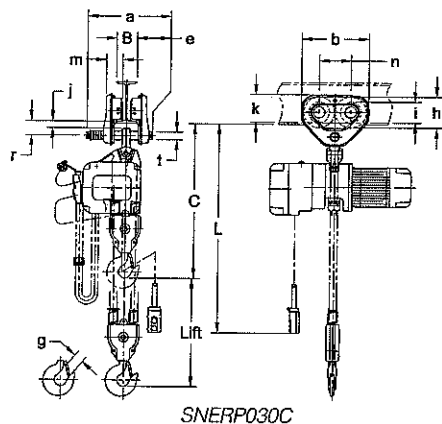

SNERP030C

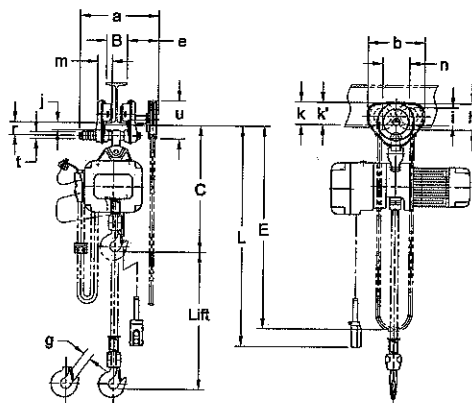

SNERG020L

SINGLE SPEED HOIST WITH PUSH OR GEARED TROLLEY—SPECIFICATIONS

Cap. (Tons)	Product Code	Std Lift (ft)	Push Button Cord L (ft)	Lifting Speed (ft/min)	Lifting Motor Single Phase 60 Hz			Flange Width Adjustability B (in)		Min.* Allow. Radius for curve (in)	Load Chain Dia. (mm) x Chain Fall Lines	Net Weight (lbs)	Weight for Additional One Foot of Lift (lbs)	
					Output (Hp)	Rated Current (amps)		Standard	Optional					
						@115V	@230V							
1/4	SNERP(SNERG)003S	15 19	11 7.5	14	0.34	7.7	3.9	2.28 to 4.00 (2.28 to 5.00)	4.01 to 8.00 (5.01 to 8.00) OR 8.01 to 12.00	43.3 (51.2)	5.0 x 1	93 (110)	0.37 (1.0)	
1/2	SNERP(SNERG)005L			7							0.6	16.9	8.5	2.28 to 5.00
1/2	SNERP(SNERG)005S			15	6.3 x 1	115 (135)	0.57 (1.2)							
1	SNERP(SNERG)010L			7	1.2	23.9	12.0	2.28 to 5.00	5.01 to 8.00 OR 8.01 to 12.00	51.2	8.0 x 1	130 (141)	0.93 (1.5)	
1	SNERP(SNERG)010S			14						51.2	8.0 x 1	179 (190)	0.93 (1.5)	
2	SNERP(SNERG)020L			7	8.2	3.5			3.23 to 6.02	6.03 to 12.00	59.1	10.0 x 1	209 (220)	1.5 (2.2)
3	SNERP(SNERG)030C										66.9	10.0 x 2	251 (262)	3.1 (3.7)

Figures in parentheses are data for geared trolley.

*Minimum flange width for curved beam: 1 Ton Push and 1/4 to 1 Ton Geared = 2.87 in.; 3 Ton Push or Geared = 3.50 in.

SINGLE SPEED HOIST WITH PUSH TROLLEY—DIMENSIONS

Cap. (Tons)	Product Code	Headroom C (in)	a (in)	b (in)	e (in)	g (in)	h (in)	i (in)	j (in)	k (in)	m (in)	n (in)	r (in)	t (in)
1/4	SNERP003S	15.4	8.0	7.2	1.8	0.9	3.2	2.36	0.7	3.0	1.9	3.3	1.5	0.87
1/2	SNERP005L	15.4	8.0	7.2	1.8	0.9	3.2	2.36	0.7	3.0	1.9	3.3	1.5	0.87
1/2	SNERP005S	16.1	8.0	7.2	1.8	0.9	3.2	2.36	0.7	3.0	1.9	3.3	1.5	0.87
1	SNERP010L	18.1	9.8	9.3	2.2	1.2	4.2	2.80	1.1	3.7	2.2	4.4	2.0	0.98
1	SNERP010S	19.5	9.8	9.3	2.2	1.2	4.2	2.80	1.1	3.7	2.2	4.4	2.0	0.98
2	SNERP020L	24.6	11.8	11.0	2.7	1.5	5.0	3.35	1.3	4.4	2.8	5.2	2.4	1.26
3	SNERP030C	29.3	12.6	12.8	3.1	1.7	5.8	3.94	1.4	5.3	3.1	6.0	2.7	1.42

SINGLE SPEED HOIST WITH GEARED TROLLEY—DIMENSIONS

Cap. (Tons)	Product Code	Headroom C (in)	E (ft)	a (in)	b (in)	e (in)	g (in)	h (in)	i (in)	j (in)	k (in)	k' (in)	m (in)	n (in)	r (in)	t (in)	u (in)
1/4	SNERG003S	16.1	10.5	13.6	9.3	6.0	0.9	4.2	2.80	1.1	3.7	4.2	2.2	4.4	2.0	0.98	7.2
1/2	SNERG005L	16.1	10.5	13.6	9.3	6.0	0.9	4.2	2.80	1.1	3.7	4.2	2.2	4.4	2.0	0.98	7.2
1/2	SNERG005S	16.9	10.5	13.6	9.3	6.0	0.9	4.2	2.80	1.1	3.7	4.2	2.2	4.4	2.0	0.98	7.2
1	SNERG010L	18.1	10.5	13.6	9.3	6.0	1.2	4.2	2.80	1.1	3.7	4.2	2.2	4.4	2.0	0.98	7.2
1	SNERG010S	19.5	10.5	13.6	9.3	6.0	1.2	4.2	2.80	1.1	3.7	4.2	2.2	4.4	2.0	0.98	7.2
2	SNERG020L	24.6	10.5	15.2	11.0	6.1	1.5	5.0	3.35	1.3	4.4	4.3	2.7	5.2	2.4	1.26	7.2
3	SNERG030C	29.3	11.0	15.7	12.8	6.2	1.7	5.8	3.94	1.4	5.3	4.5	3.1	6.0	2.7	1.42	7.2

RFP #011



UPPER DECK
ARCHITECTS, INC.

50 MINNESOTA ST. - SUITE 1
RAPID CITY, SD 57701
PH: 605 721-0237
FAX: 605 721-0240

Jerry D. Eisenbraun

From: Johnson Rod <Rod.Johnson@rcgov.org>
Sent: Monday, February 16, 2015 12:55 PM
To: Jerry D. Eisenbraun
Cc: Neal Schlottman
Subject: RE: RCUMF RFP #-11 Recommendation

Please proceed with RFP #11 and include in the next change order.

RJ

From: Jerry D. Eisenbraun [<mailto:jerrye@upperdeckarchitects.com>]
Sent: Thursday, February 12, 2015 10:14 AM
To: Johnson Rod
Subject: RCUMF RFP #-11 Recommendation

Attached is our recommendation for RFP #011. This is the hardware change that was required by Chip that we all thought was part of RFP #005.

Project Manager

UPPER DECK ARCHITECTS, INC.

50 Minnesota Street - Suite 1

Rapid City, SD 57701

PH (605) 721-0237

FX (605) 721-0240

Visit us at: www.upperdeckarchitects.com

RFP #011 RECOMMENDATION



UPPER DECK
ARCHITECTS, INC.

50 MINNESOTA ST. - SUITE 1
RAPID CITY, SD 57701
PH: 605 721-0237
FAX: 605 721-0240

To: Rod Johnson

Project: Rapid City Utility Maintenance Facility Project #: 13373

From: Jerry D. Eisenbraun Date: 2/12/2015

Content: RFP #011 Recommendation

Rod:

Attached is the pricing information from SECO Construction, Inc. for Proposal Request No. 11 – Modify hardware at seven locations. Change was initiated by the user at time of keying coordination with the hardware supplier. We made an error when making our recommendation for RFP #005 and had thought that this hardware request had been included; that RFP was only for revising electronic hinges.

We recommend acceptance of RFP #011 for a cost **add of \$5,924.00**. If this is acceptable, please forward to us your decision regarding this item, and we will ensure this is incorporated into the next change order. Please note deadline for approval before additional time needs to be considered however per my discussion with SECO Construction, we did not received these costs until 2/11/15.

Sincerely,
Jerry D. Eisenbraun



P.O. BOX 2921 RAPID CITY, SD 57709 (605)348-7085 FAX (605)348-8287

January 28, 2015

VIA EMAIL

Mr. Jerry Eisenbraun
Upper Deck Architects, Inc.
50 Minnesota Street, Suite 1
Rapid City, SD 57701

Subject: Proposal for RFP #11, Rapid City Utility Maintenance Facility, Rapid City, SD

Dear Jerry,

We propose to provide the door hardware and security system changes as outlined in Request for Proposal #11 dated January 21, 2015 for an additional cost of \$5,924.00. The estimate cost summary sheet for this work and associated documentation are enclosed for your review.

The work outlined in this proposal request will not require a contract time change if we receive written notice to proceed on this proposal no later than February 3, 2015.

Sincerely,
SECO Construction, Inc.

A handwritten signature in black ink, appearing to read "Neal A. Schlottman", is written over a horizontal line.

Neal A. Schlottman
President

enclosures



SECO Construction, Inc.
REQUEST FOR PROPOSAL COST SUMMARY
Rapid City Utility Maintenance Facility

Proposal Request No. 11

	<u>Work Description</u>	<u>Amount</u>
<u>Subcontractors</u>		
AI Sutton Electric	Electrical and Security Revisions Door 101A	1,423.18
SUBCONTRACTOR SUBTOTAL		<u>1,423.18</u>
<u>GC Labor</u>		
Additional Supervision		60.00
Hardware Revisions for Items 1, 2, 3 and 5 - No cost change		-
Hardware Revisions Item 4 - Deduct closer and add power operator and push buttons		120.00
LABOR SUBTOTAL		<u>180.00</u>
<u>GC Materials</u>		
North Central Supply	Hardware Changes (see attached)	3,140.53
MATERIAL SUBTOTAL		<u>3,140.53</u>
Sales Tax	6.00%	188.43
LABOR SUBTOTAL		180.00
GC Overhead	8%	280.72
SUBCONTRACTOR TOTAL		<u>1,423.18</u>
SUBTOTAL		5,212.86
GC Profit	10%	<u>521.29</u>
SUBTOTAL		5,734.14
Bond/Insurance	1.25%	71.68
State Excise Tax	2.041%	118.50
TOTAL		<u>5,924.32</u>
TOTAL THIS PROPOSAL		\$ 5,924

AL SUTTON ELECTRIC, INC.

PO Box 3538
Rapid City, SD 57709

Office (605) 341-5300
Fax (605) 342-1686

January 27, 2015

Seco Construction

RE: City of Rapid City, Utility Maintenance Facility RFP 011

Price for RFP 11 based on attached documentation
\$1423.18

Thanks,



Albert G. Sutton
President
Al Sutton Electric

BID SUMMARY REPORT

Name: Utility Maintenance Facility

Estimator: Admin

Job #: 60

Job Name: Utility Maintenance Facility

Contractor:

Estimator: Admin

Notes:

Bid Date:

Included	Summary Description	Extended	%	Adjusted Material	Extended	%	Adjusted Labor
<input type="checkbox"/>	RFP 11	\$227.72	100.00	\$227.72	12.98	100.00	12.98

Top Sheet

Raw Cost	\$1,253.61	Sales Per Month	\$0.00
Tax	\$40.18	Return Per Month	\$0.00
Raw Cost With Tax	\$1,293.80	Price Per Sq Foot	\$0.00
Overhead	\$0.00	Hours Per Sq Foot	0.00
Profit	\$129.38	Square Feet	0.00
Total Return \$	\$129.38	Job Months	0.00
Total Return %	9.09	Hours per Week	40.00
Price	\$1,423.18	Workers Per Day	0.00
Bond	\$0.00	Total Hours	12.98
Sell Price	\$1,423.18	Mark Up Sales Tax? Yes	
Sell Adjusted By:	\$0.00	Use Bond Table? No	
Adj Sell Return	0		\$0.00

Labor

ClassDescription	Percent of Total	Hours Distributed	Hourly Rate	Burden Rate	Percent	Labor Cost
	100.00%	12.98	\$45.00	\$0.00	0.00%	\$583.90
Totals:	100.00%	12.98	\$45.00	\$0.00	0.00%	\$583.90

MARK UPS

	OVERHEAD		PROFIT		
	Total	%	Amount	%	Amount
Materials	\$227.72	0.00%	\$227.72	10.00%	\$250.49
Labor	\$583.90	0.00%	\$583.90	10.00%	\$642.29
Supplier Quotes	\$442.00	0.00%	\$442.00	10.00%	\$486.20
SubContractors	\$0.00	0.00%	\$0.00	10.00%	\$0.00
Direct Job Expense	\$0.00	0.00%	\$0.00	10.00%	\$0.00
Equipment Rental	\$0.00	0.00%	\$0.00	10.00%	\$0.00
Totals:	\$1,253.61	0.00%	\$1,253.61	10.00%	\$1,378.98

TAX Report

	Taxed Amount	Tax Rate %	Tax Amount
Materials	\$227.72	6.00%	\$13.66
Labor	\$583.90	0.00%	\$0.00
Supplier Quotes	\$442.00	6.00%	\$26.52
SubContractors	\$0.00	6.00%	\$0.00
Direct Job Expense	\$0.00	6.00%	\$0.00
Equipment Rental	\$0.00	6.00%	\$0.00
		Total Tax:	\$40.18

Supplier Quotes

BID SUMMARY REPORT

Name: Utility Maintenance Facility

Estimator: Admin

Job #: 60

Name	Supplier	Tax (6%)	Unit	Multiplier	Dollars
Security Equipment	johnson	Yes	\$442.00	1.00	\$442.00
Total:					\$442.00

Items

Item #	Item Name	Quantity	Crescent u	BSE u	Price 1 u	Ext Price 1	Bid Lbr u	Bid Lbr Ext	CCode
11	12 THHN CU STRAND	220.50	\$.00 E	\$.00 E	\$153.12 M	\$33.76	4.00 M	.88	wb
1,060	1/2 EMT	70.00	\$.00 E	\$.00 E	\$40.37 C	\$28.26	2.00 C	1.40	cb
1,061	3/4 EMT	120.00	\$.00 E	\$.00 E	\$63.22 C	\$75.86	3.00 C	3.60	cb
1,142	3/4 EMT CONN D/C	4.00	\$.00 E	\$.00 E	\$116.69 C	\$4.67	5.00 C	.20	cb
1,165	1/2 EMT CONN S/S	7.00	\$.00 E	\$.00 E	\$25.19 C	\$1.76	4.00 C	.28	cb
1,166	3/4 EMT CONN S/S	10.00	\$.00 E	\$.00 E	\$41.01 C	\$4.10	5.00 C	.50	cb
1,237	1/2 EMT COUP S/S	7.00	\$.00 E	\$.00 E	\$33.44 C	\$2.34	3.00 C	.21	cb
1,238	3/4 EMT COUP S/S	10.00	\$.00 E	\$.00 E	\$50.44 C	\$5.04	3.50 C	.35	cb
1,332	1/2 EMT 1 HOLE STP/	8.75	\$.00 E	\$.00 E	\$41.90 C	\$3.67	3.00 C	.26	cb
1,333	3/4 EMT 1 HOLE STP/	16.50	\$.00 E	\$.00 E	\$56.00 C	\$9.24	3.00 C	.50	cb
2,984	3/4 BUSH PLASTIC	4.00	\$.00 E	\$.00 E	\$43.04 C	\$1.72	4.90 C	.20	cb
3,833	10 X 1-1/2 COMB PA	21.25	\$.00 E	\$.00 E	\$2.03 C	\$.43	.00 X	.00	ch
3,895	1/4 FLAT STEEL WAS	21.25	\$.00 E	\$.00 E	\$58.32 C	\$12.39	.00 X	.00	ch
21,822	16/2 SHIELD PLENU	100.00	\$.00 E	\$.00 E	\$444.70 M	\$44.47	16.00 M	1.60	vc
47,461	1 HOUR LABOR (MIS	3.00	\$.00 X	\$.00 X	\$.00 X	\$.00	1.00 E	3.00	am
100,011	Stub up device 1 hr	1.00	\$.00 E	\$.00 E	\$.00 Q	\$.00	.00 X	.00	lf
100,012	Stub up deviced 2 hr	1.00	\$.00 E	\$.00 E	\$.00 Q	\$.00	.00 X	.00	lf
Totals						\$227.72		12.98	



Proposal

To: Al Sutton Electric

January 23rd, 2015

Project: RC Utility Maintenance Facility
RFP-11 Access Control System

Johnson Controls, Inc. (JCI) has reviewed RFP-11 and has provided the following proposal. JCI will furnish all security related equipment for this project in addition to the labor associated with the programming, testing and commissioning. Please see the bill of materials as listed below.

RFP-11 Access Control System:

\$ 442.00

RFP-11 Access Control System - Bill of Materials:

<u>Qty.</u>	<u>Model #</u>	<u>Description</u>
+1	PAM-2	Coil Relay, Tri-Voltage
+1	LOT	Labor, Programming, Testing, and Commissioning

Our proposed Access Control System Option does NOT include the following:

- Electrical installation, cable, field device terminations
- Excise Tax (to be furnished by the GC)

Sales & Use Tax included
Payment Terms: Net45

Johnson Controls, Inc.
3413 Gateway Blvd.
Sioux Falls, SD 57106

Direct (605) 361-0680
FAX 605) 361-6773

NORTH CENTRAL SUPPLY, INC.
HOLLOW METAL DISTRIBUTOR ~ BUILDERS HARDWARE
ARCHITECTURAL WOOD DOOR SUPPLIER
P.O. Box 380 - Rapid City, SD 57709
Ph. (605)343-5486 / Fax (605)355-8830

Cost Proposal

DATE: 1-28-15 **Proposal Request: #11 (R)**

Total number of pages including cover: 2

Contractor: SECO Construction

NCS Job #: C6314

Project: Rapid City Utility Maintenance Facility

Contact: Neal

Description: Hardware changes. See attached worksheet for details.

Hardware Addition Price: \$3,140.53
6% Sales Tax: \$188.43

Total Addition Price: \$3,328.96

The above changes will not be processed without a fully executed Change Order. Your return of this signed proposal indicates acceptance and will allow NCS to proceed with the proposed changes prior to receiving the formal change order. Please fax to 605-355-8830 immediately if we are to proceed.

Contractor

North Central Supply, Inc.

By: _____

By: **Chad Johnston**

Position: _____

Date: _____

JOB #	C6314		Rapid City Utility Maintenance Facility		
RFP#					
HARDWARE CHANGES					
HDWE GROUP	TAG	QTY	DESCRIPTION	MANUFACTURER	PRICE
4	103	-1	CL3351 NZD 626	CORBIN RUSSWIN	-\$208.68
4.1	103	1	CL3310 NZD 626	CORBIN RUSSWIN	\$101.20
6	110	-1	CL3310 NZD 626	CORBIN RUSSWIN	-\$101.20
6.1	110	1	CL3351 NZD 626	CORBIN RUSSWIN	\$208.68
9	118	-1	70E US32D	ROCKWOOD	-\$6.00
9	118	-1	107X70C USD32D	ROCKWOOD	-\$15.00
9.1	118	1	CL3351 NZD 626	CORBIN RUSSWIN	\$208.68
1	101A	-1	DC6210 689 M54	CORBIN RUSSWIN	-\$92.68
1.1	101A	1	6060-RF D 689	NORTON	\$3,002.21
1.1	101A	1	533	NORTON	\$123.53
6	101B	-1	CL3310 NZD 626	CORBIN RUSSWIN	-\$101.20
6.2	101B	1	70E US32D	ROCKWOOD	\$6.00
6.2	101B	1	107X70C USD32D	ROCKWOOD	\$15.00
2		-3	ED5200S N957 630	CORBIN RUSSWIN	-\$1,490.79
2		3	ED5200S N955 630	CORBIN RUSSWIN	\$1,490.79
					\$0.00
					\$0.00
					\$0.00
					\$3,140.53



Document G709™ – 2001

Work Changes Proposal Request

PROJECT (Name and address):
Rapid City Utility Maintenance
Facility
Rapid City, South Dakota

PROPOSAL REQUEST NUMBER: 011

OWNER:

ARCHITECT:

CONSULTANT:

CONTRACTOR:

FIELD:

OTHER:

OWNER (Name and address):
City of Rapid City
300 6th Street
Rapid City, SD 57701

DATE OF ISSUANCE: January 21, 2015

CONTRACT FOR: General Construction

CONTRACT DATE: September 17, 2014

FROM ARCHITECT (Name and address):
Upper Deck Architects, Inc.
50 Minnesota Street
Suite 1
Rapid City, SD 57701

ARCHITECT'S PROJECT NUMBER: 13373

TO CONTRACTOR (Name and address):
SECO Construction, Inc.
P.O. Box 2921
Rapid City, SD

Please submit an itemized proposal for changes in the Contract Sum and Contract Time for proposed modifications to the Contract Documents described herein. Within seven (7) days, the Contractor must submit this proposal or notify the Architect, in writing, of the date on which proposal submission is anticipated.

THIS IS NOT A CHANGE ORDER, A CONSTRUCTION CHANGE DIRECTIVE OR A DIRECTION TO PROCEED WITH THE WORK DESCRIBED IN THE PROPOSED MODIFICATIONS.

DESCRIPTION (Insert a written description of the Work):

1. Opening 103: Modify opening from Hardware Set 4 to Hardware set 6.
2. Opening 110: Modify opening from Hardware Set 6 to Hardware set 4.
3. Openings 115A, 123B, and 124D (Hardware Set 2): Provide classroom function in lieu of function specified. All remaining hardware to remain the same.
4. Opening 101A (Hardware Set 1): Add low energy ADA power operator with RF function.
 - Electrical Sheet E-201 Main Level Power Plan:
 - a. Provide a 20A circuit to Door 101A to power up ADA low-power operator. Power for L2-24. Pushbuttons will be wireless.
 - Electrical Sheet #301 Main Level Signal Plan:
 - a. Card Access - Security system to add interface with HVAC. Coordinate interconnection with HVAC and ADA release unit with security system. See attached interlock. Card access to also add a release relay at ADA operator.
5. Opening 101B (Hardware Set 6): Provide push/pull function in lieu of classroom function specified. All remaining hardware to remain the same.

ATTACHMENTS (List attached documents that support description):

ESK-1

REQUESTED BY THE ARCHITECT:

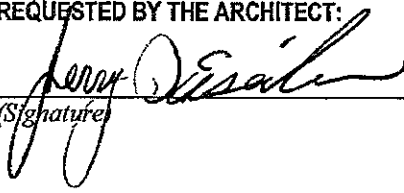
(Signature)

Jerry Eisenbraun, Project Manager
(Printed name and title)

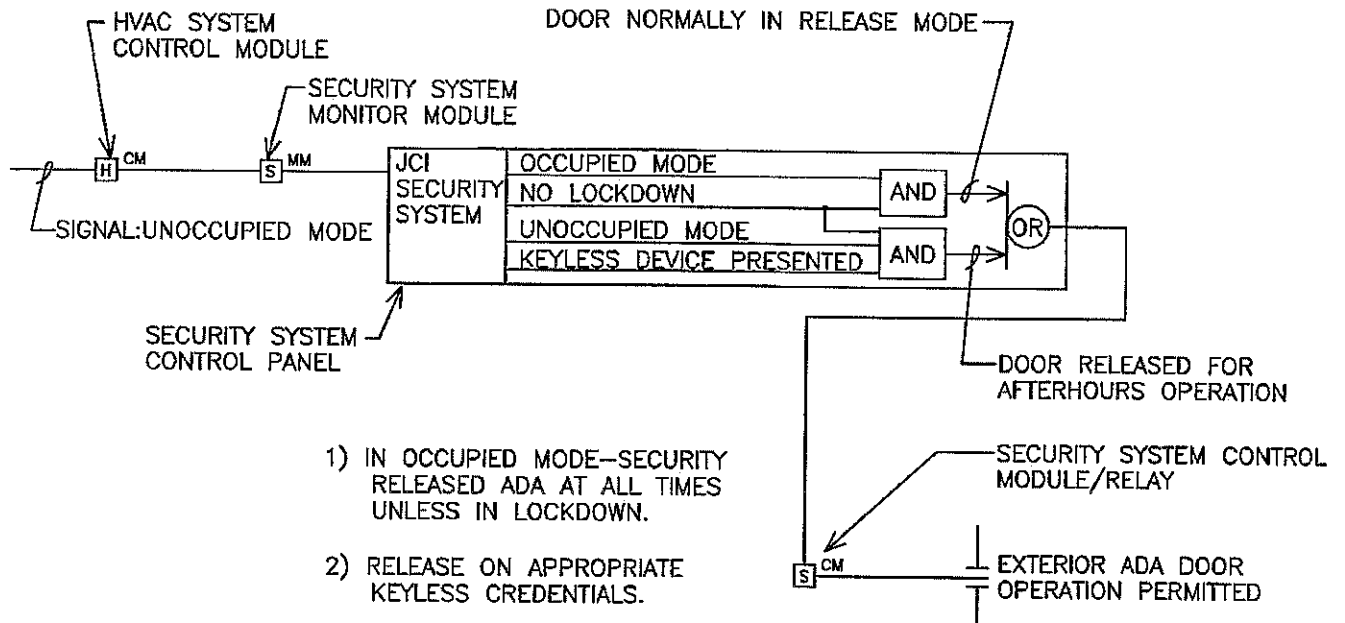

NOTE: INTERLOCKS DO NOT APPLY TO INTERIOR DOORS

7 ADA FUNCTIONAL/INTERLOCK LOGISTICAL DIAGRAM

SCALE: N.T.S.

RFP-011

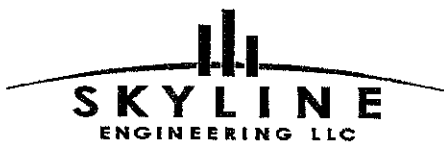
 <p>SKYLINE ENGINEERING LLC</p> <p>615 12th Street Rapid City, SD 57701</p> <p>Tel: 605.737.3800 Fax: 605.737.3859</p>	PROJECT CITY OF RAPID CITY UTILITY MAINTENANCE FACILITY		SHEET ESK1	
	SHEET TITLE ELECTRICAL DETAILS		REF SHEET: E-700	
	PROJECT NO. 13028	DRAWN BY SMD	CHECKED BY JBS	DATE: 1-22-15